

烙克赛克保留所有权利。未经授权严禁复制，
使用以及向第三方泄漏。

All rights reserved. Unauthorized reproduction, use
or disclosure to third parties is strictly forbidden

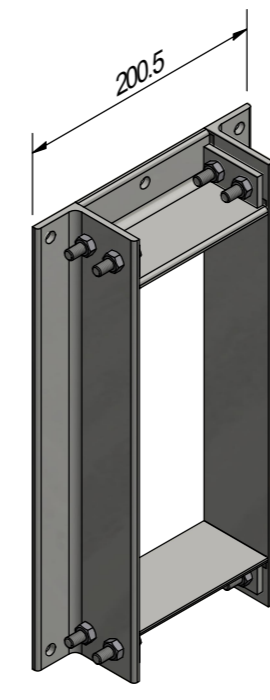

SIZE 8x1

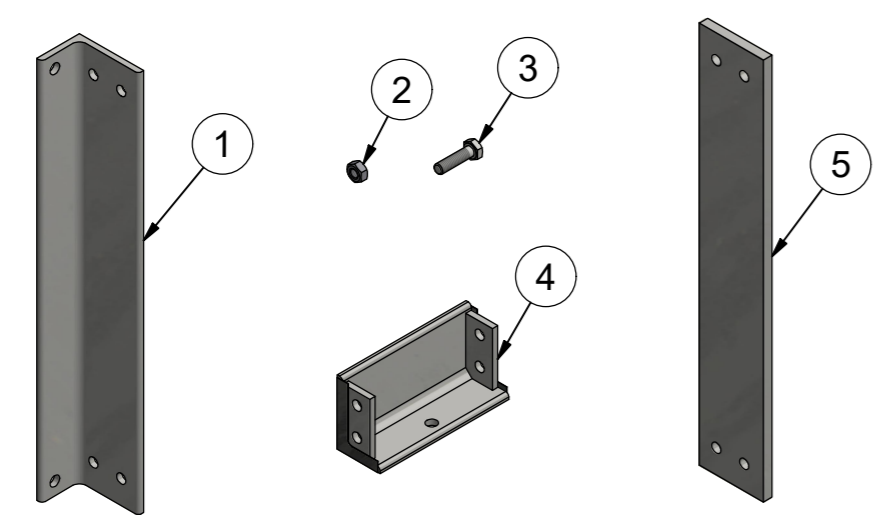
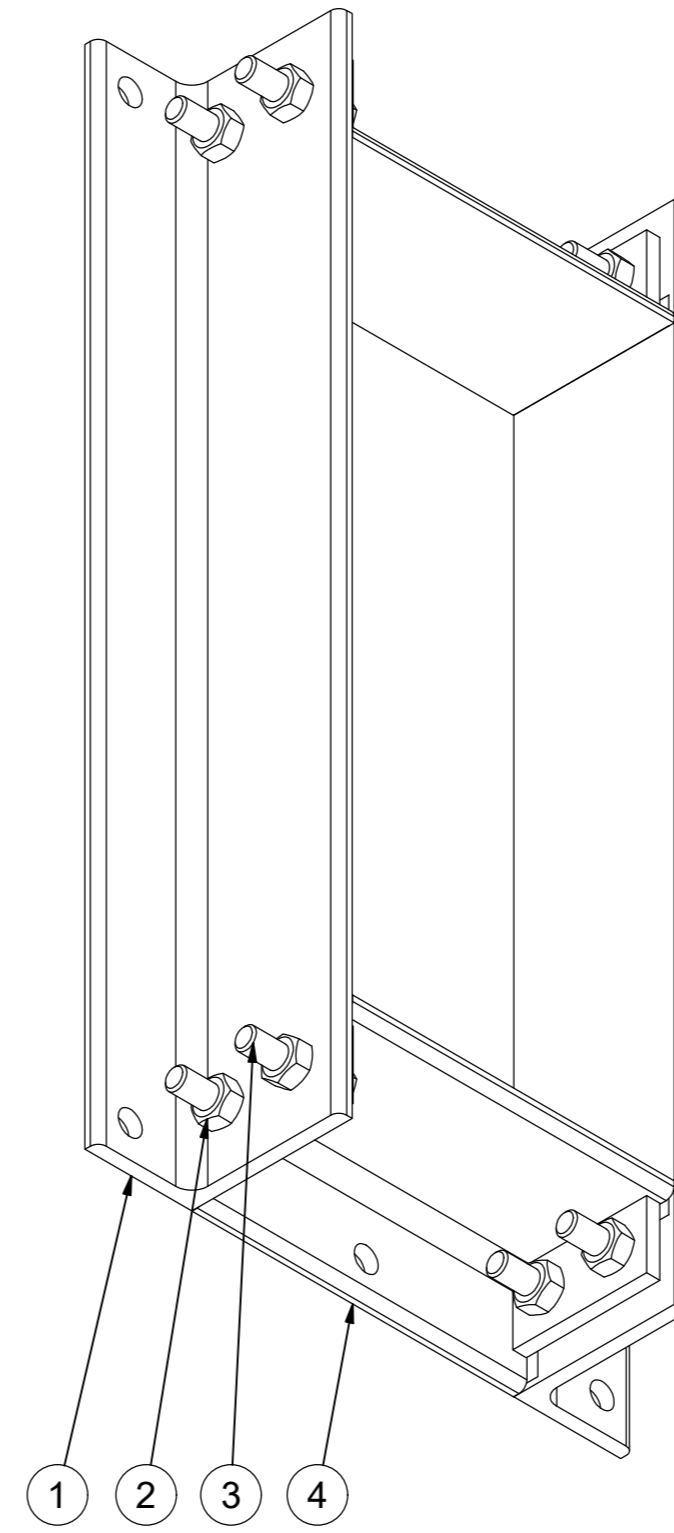
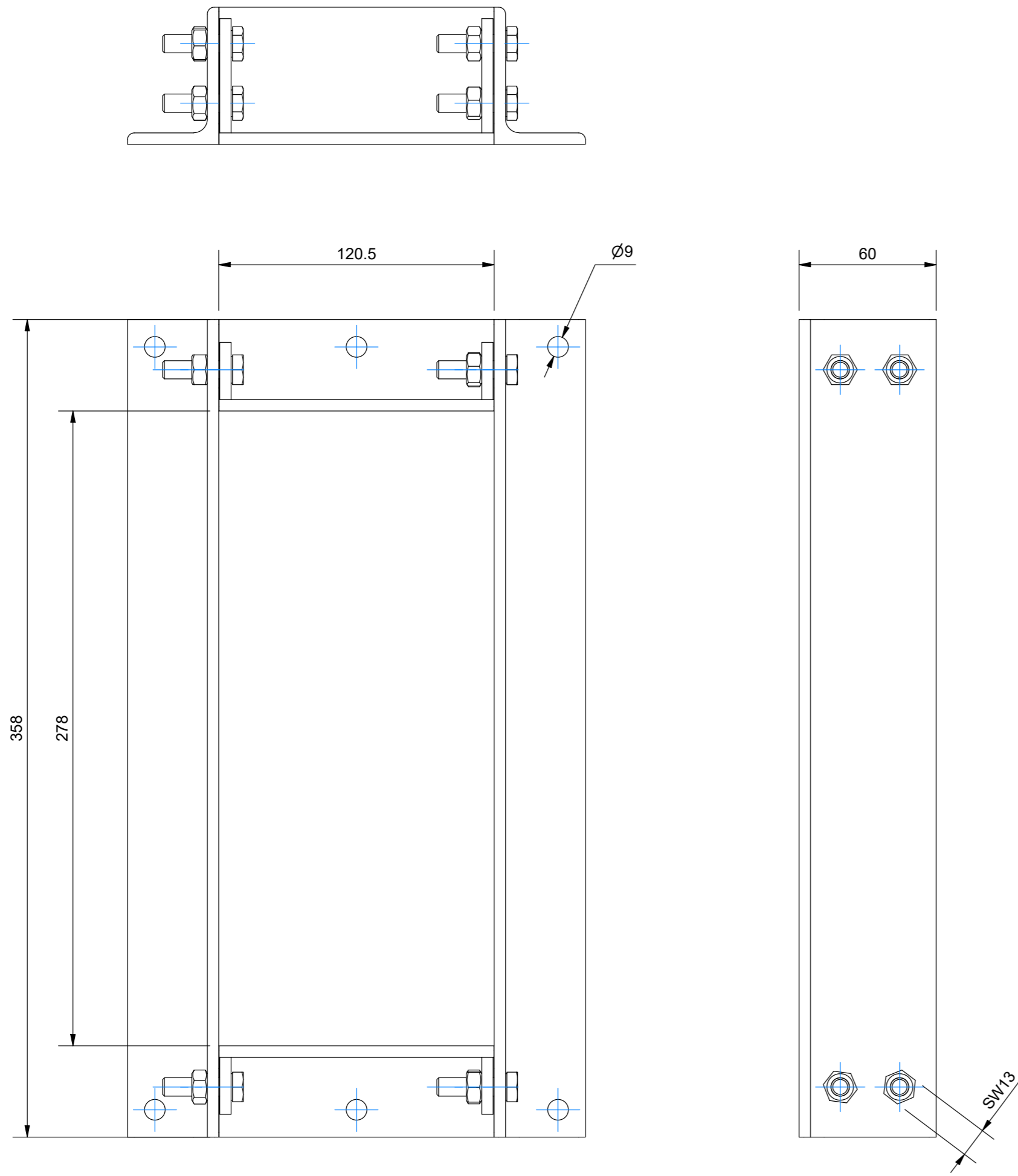
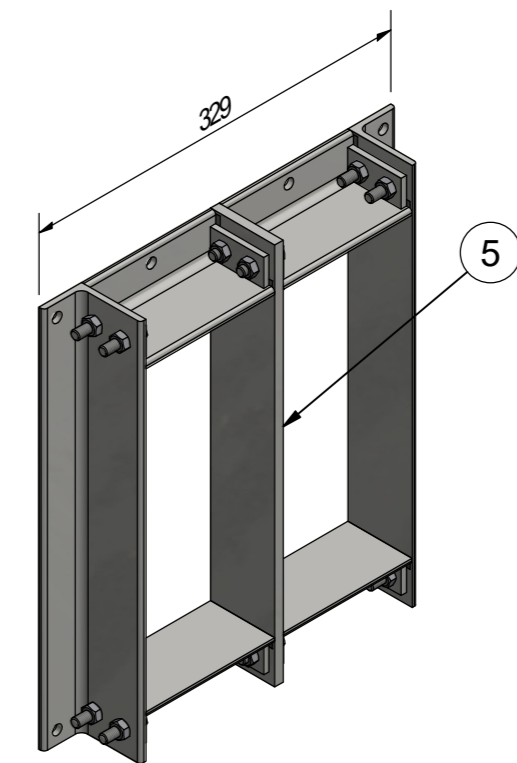

SIZE 8x2

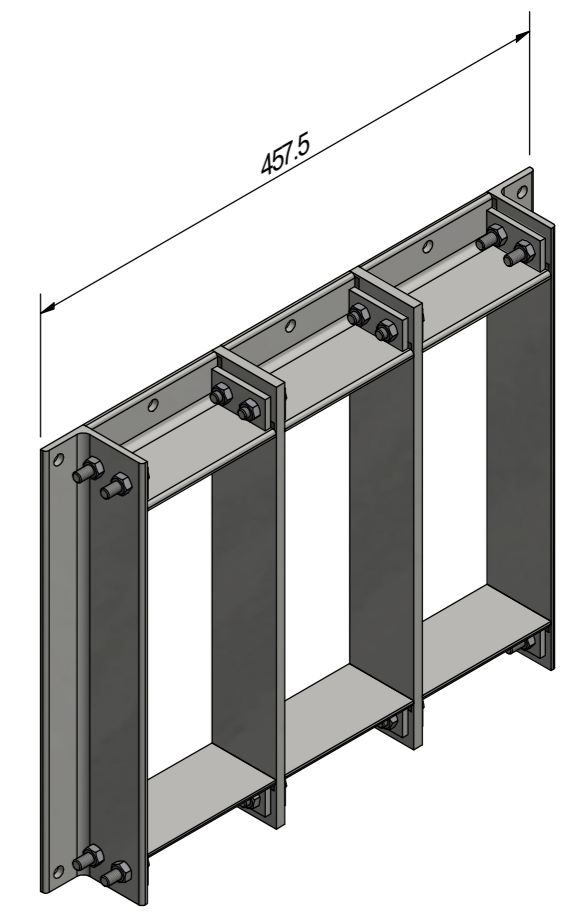

SIZE 8x3

SIZE 8x1			
ITEM	QTY	Designation	Specification
1	2	LONG SIDE	
2	8	NUT	M8 ISO 4032
3	8	SCREW	M8x30 ISO 4017
4	2	SHORT SIDE	

SIZE 8x2			
ITEM	QTY	Designation	Specification
1	2	LONG SIDE	
2	12	NUT	M8 ISO 4032
3	12	SCREW	M8x30 ISO 4017
4	4	SHORT SIDE	
5	1	PARTITION WALL	

SIZE 8x3			
ITEM	QTY	Designation	Specification
1	2	LONG SIDE	
2	16	NUT	M8 ISO 4032
3	16	SCREW	M8x30 ISO 4017
4	6	SHORT SIDE	
5	2	PARTITION WALL	

NOTE: FASTENERS INCLUDED WITH SHORT SIDE

Rev	Type of revision	Date	Sign
A		2023-04-17	se-parham

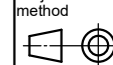
General tolerances used for manufacturing shown in document DOC-002180		Designed by/date se-parham 2023-04-17	Latest save date 2023-05-05	Format A2	Scale	Sheet no 1 / 1	TotWeight 3,9 kg
 Roxtec www.roxtec.com		Title B FRAME SIZE 8 ASSEMBLY			Projection method 		Rev A
		Restricted due to		Drawing number S1590993			

Information drawings show general design and nominal dimensions if not else stated