

烙克赛克保留所有权利。未经授权严禁复制，使用以及向第三方泄漏。

All rights reserved. Unauthorized reproduction, use or disclosure to third parties is strictly forbidden

Rev 3.1

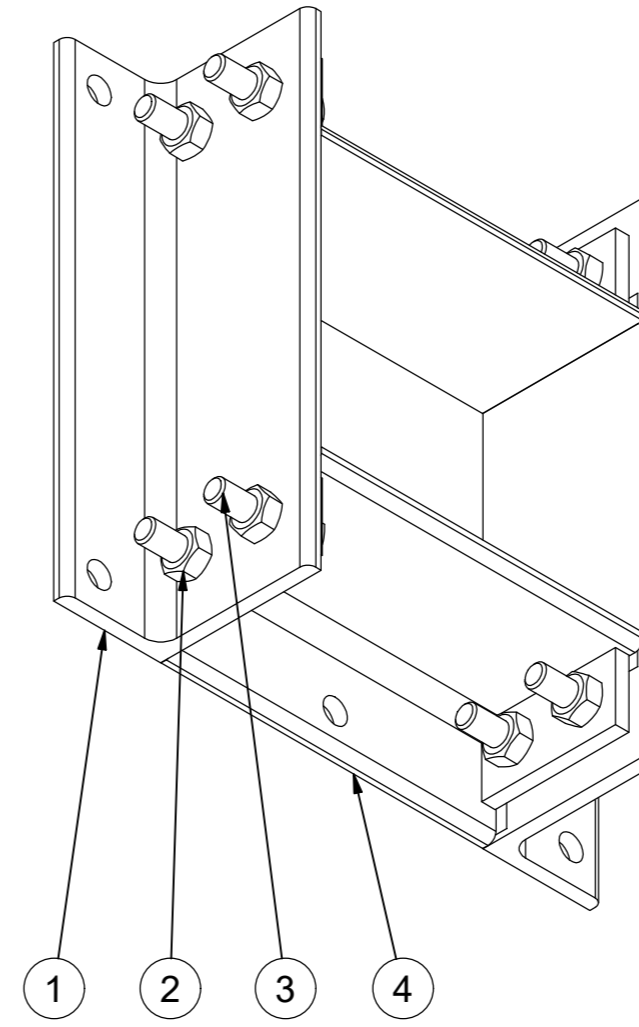
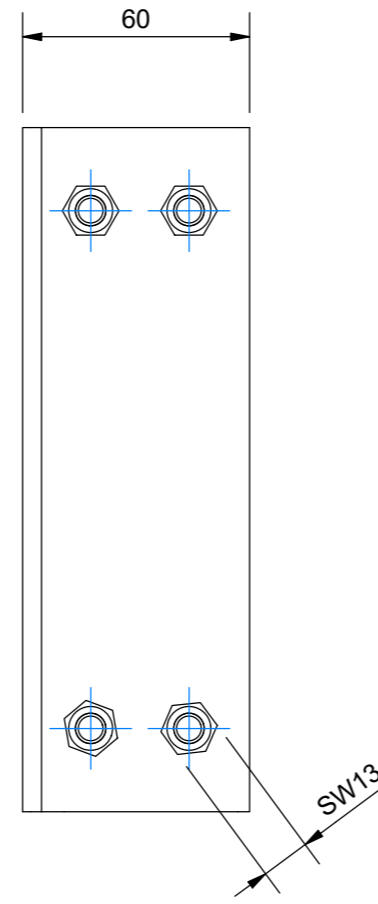
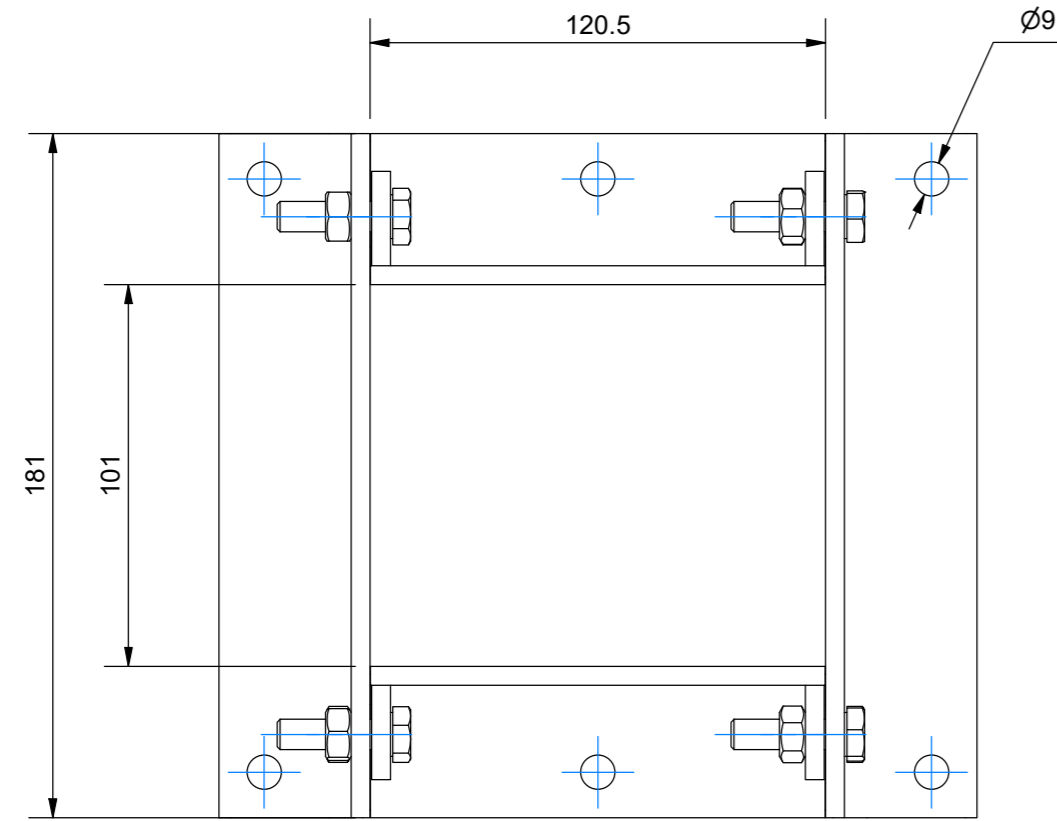
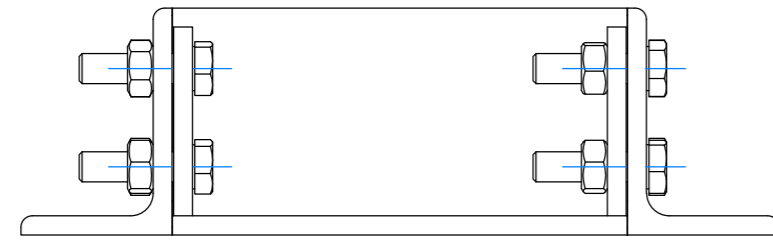

SIZE 2x1			
ITEM	QTY	Designation	Specification
1	2	LONG SIDE	
2	8	NUT	M8 ISO 4032
3	8	SCREW	M8x30 ISO 4017
4	2	SHORT SIDE	

SIZE 2x2			
ITEM	QTY	Designation	Specification
1	2	LONG SIDE	
2	12	NUT	M8 ISO 4032
3	12	SCREW	M8x30 ISO 4017
4	4	SHORT SIDE	
5	1	PARTITION WALL	

SIZE 2x3			
ITEM	QTY	Designation	Specification
1	2	LONG SIDE	
2	16	NUT	M8 ISO 4032
3	16	SCREW	M8x30 ISO 4017
4	6	SHORT SIDE	
5	2	PARTITION WALL	

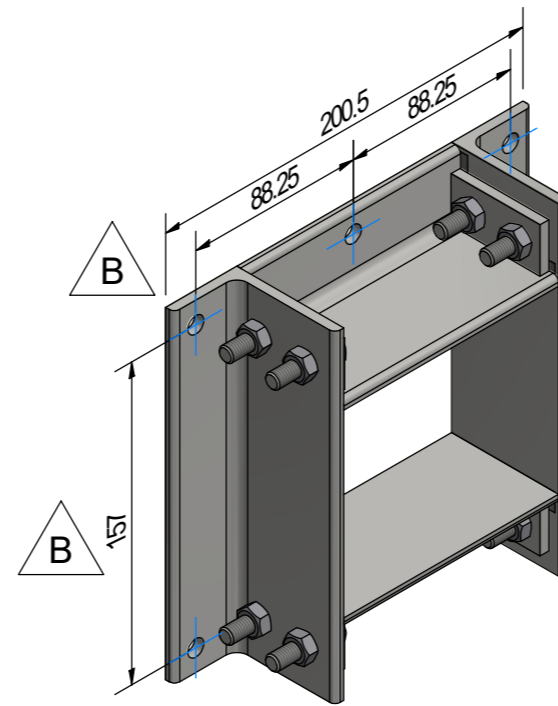
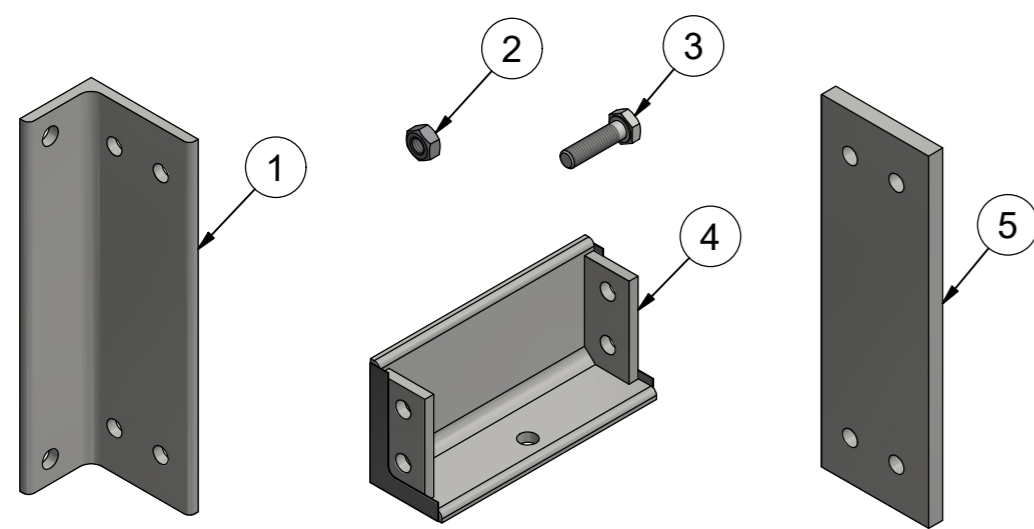

SIZE 2x1

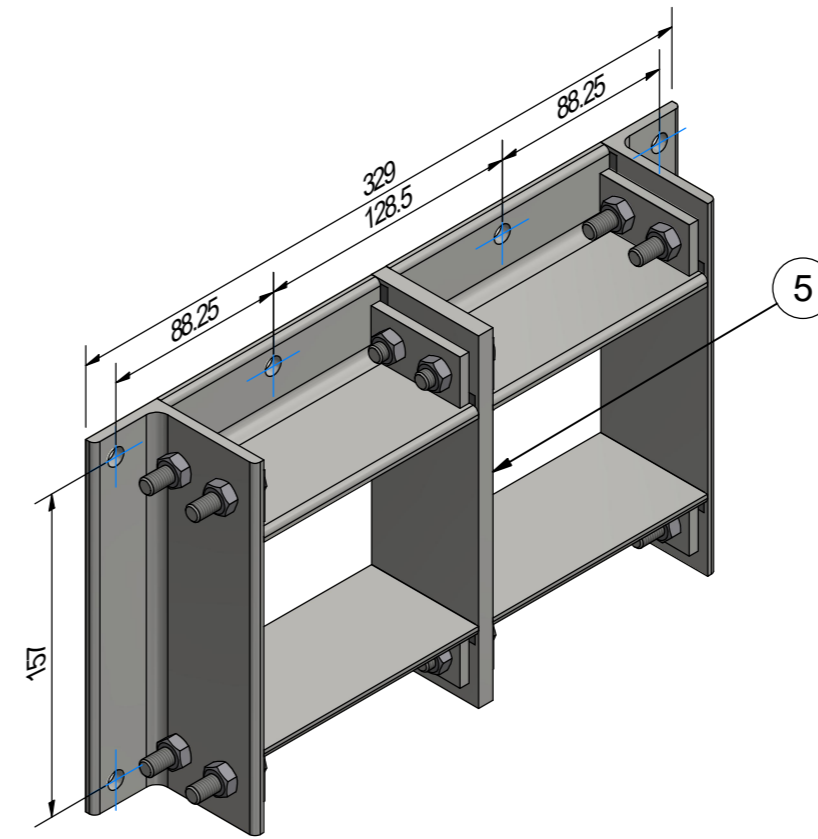

SIZE 2x2

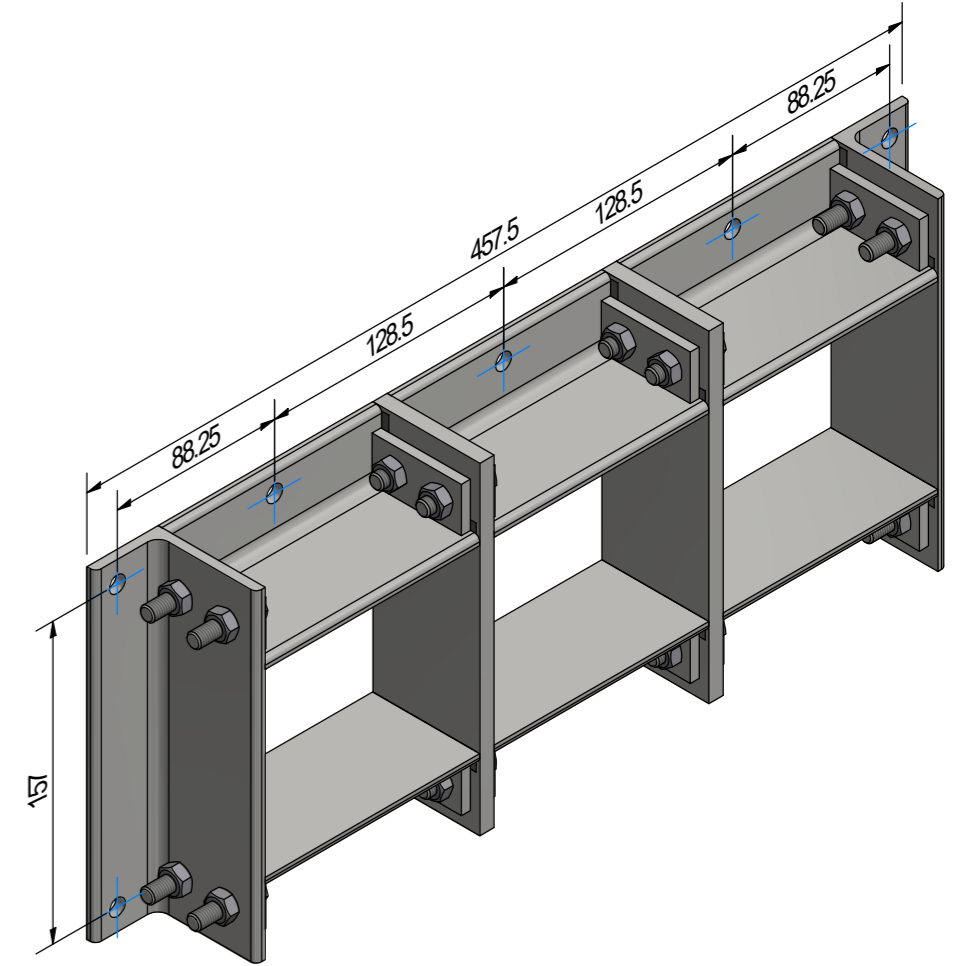

SIZE 2x3

NOTE: FASTENERS INCLUDED WITH SHORT SIDE

Rev	Type of revision	Date	Sign
B	DIMENSION HOLE PATTERN ADDED	2023-12-06	se-parham

General tolerances used for manufacturing shown in document DOC-002180		Designed by/date se-parham 2023-03-27	Latest save date 2023-12-07	Format A2	Scale	Sheet no 1 / 1	TotWeight 2.6 kg
 www.roxtec.com		Title B FRAME SIZE 2 ASSEMBLY		Projection method 		Drawing number S1590412	
Restricted due to Information drawing						Rev B	

Information drawings show general design and nominal dimensions if not else stated