

洛克赛克保留所有权利。未经授权严禁复制、使用以及向第三方泄露。

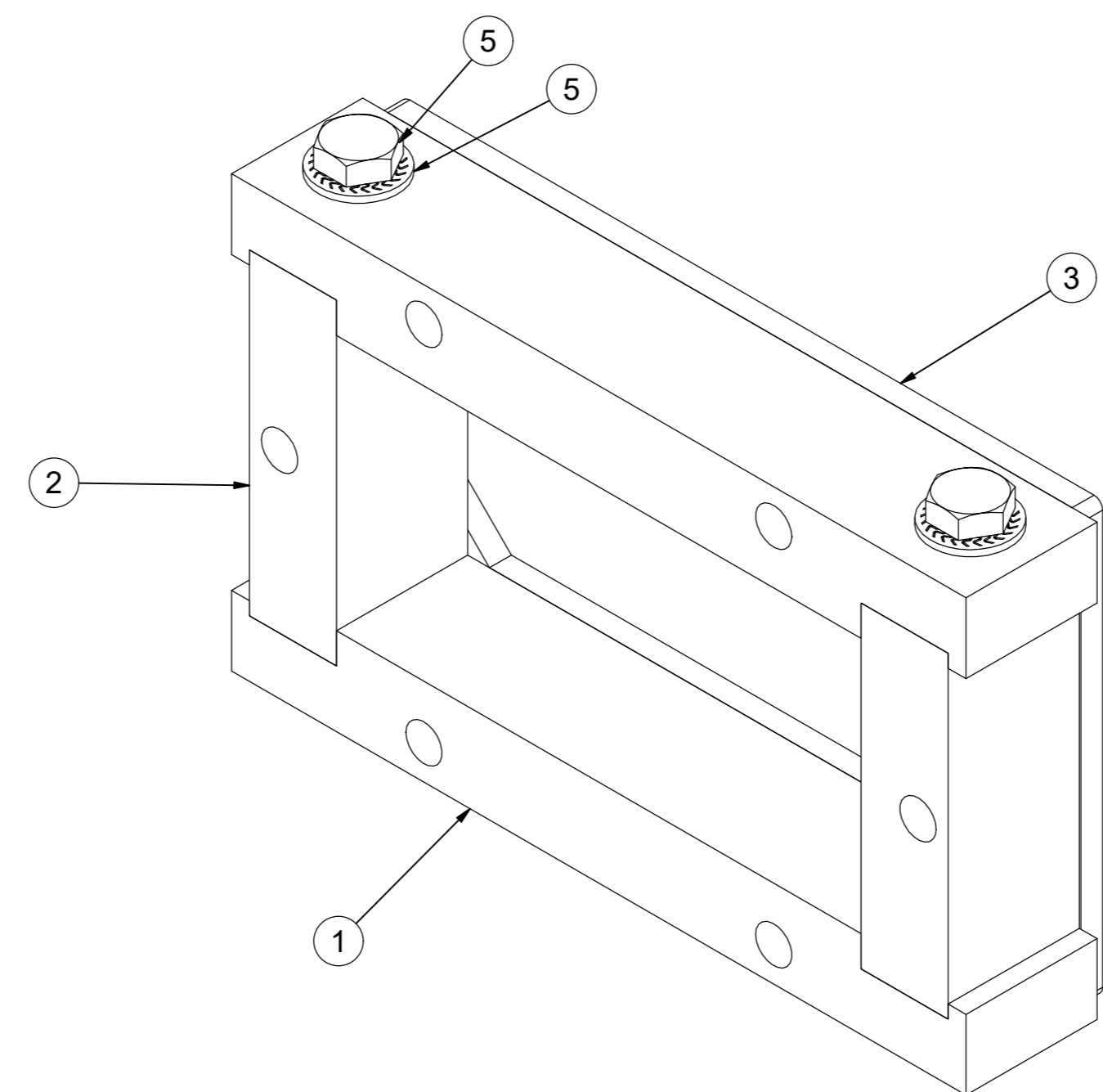
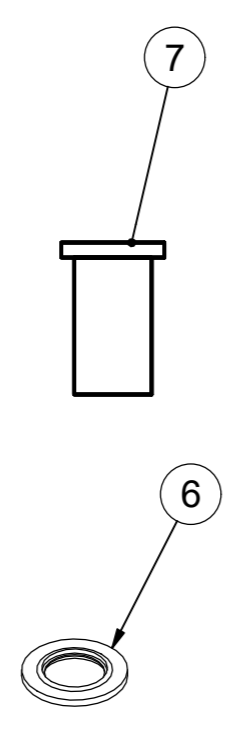
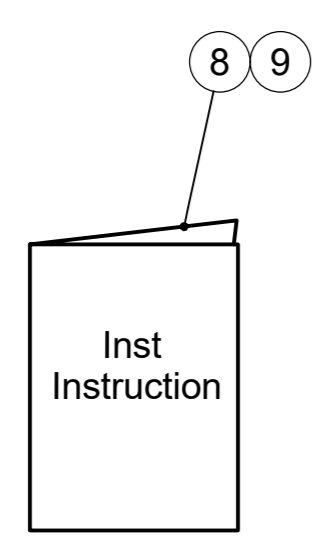
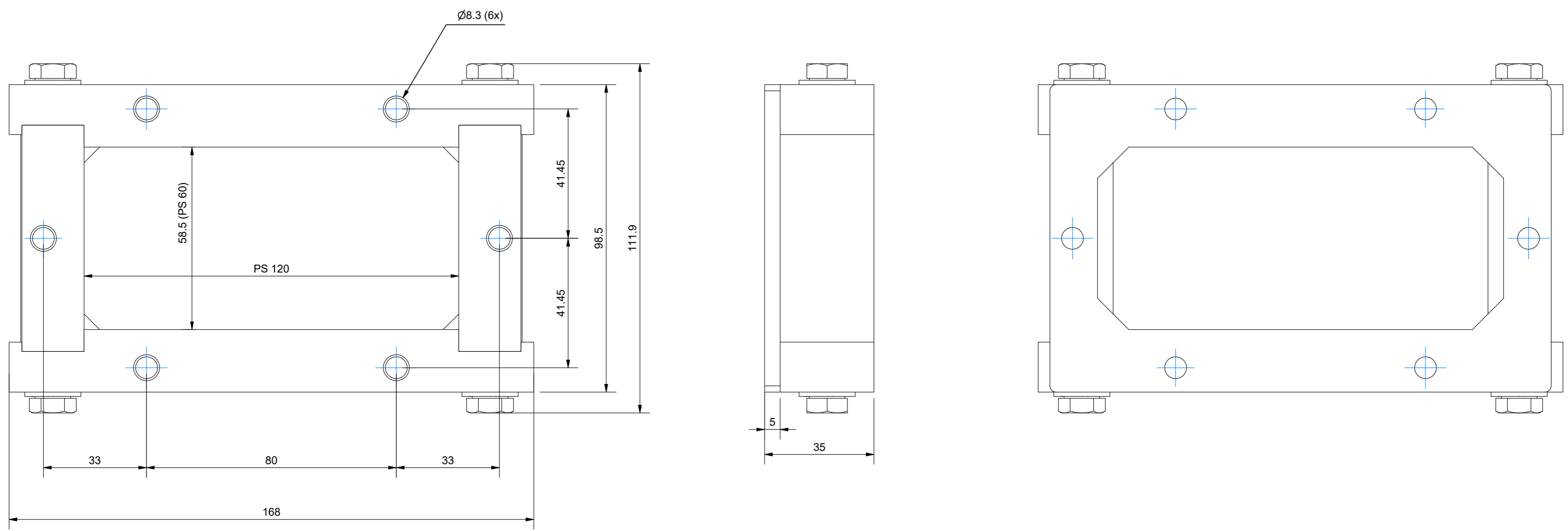

ITEM	QTY	Designation	Specification	Weight
9	1	INSTALLATION INSTRUCTION CM		
8	1	INSTALLATION INSTRUCTION CRF		
7	1	LUBRICANT BLUE		
6	6	SEALING WASHER	M8 A4	
5	4	SERRATED WASHER	NSK-M A4 M8 (192137)	
4	4	SCREW	M6S M8x35 ISO 4017 A4-70	
3	1	GASKET PS 60x60	CELLULAR RUBBER	
2	2	SHORT SIDE 60 LS20	ALUMINIUM	0.1
1	2	LONG SIDE 120	ALUMINIUM	0.2
ITEM QTY		Designation	Specification	Weight
General tolerances used for manufacturing shown in document DOC-002180		Designed by/date se-robgus 2022-04-01	Latest save date 2022-04-27	Format A2
		Title CRF 60x120 ASSEMBLY	Scale 1 / 1	Sheet no 1 / 1
		www.roxtec.com	Information drawing	Drawing number S1578377
		Rev	B	

Rev	Type of revision	Date	Sign
B	COMPONENT REMOVED.	2022-04-27	se-robgus

Information drawings show general design and nominal dimensions if not else stated

Rev 2.0 All rights reserved. Unauthorized reproduction, use or disclosure to third parties is strictly forbidden.