

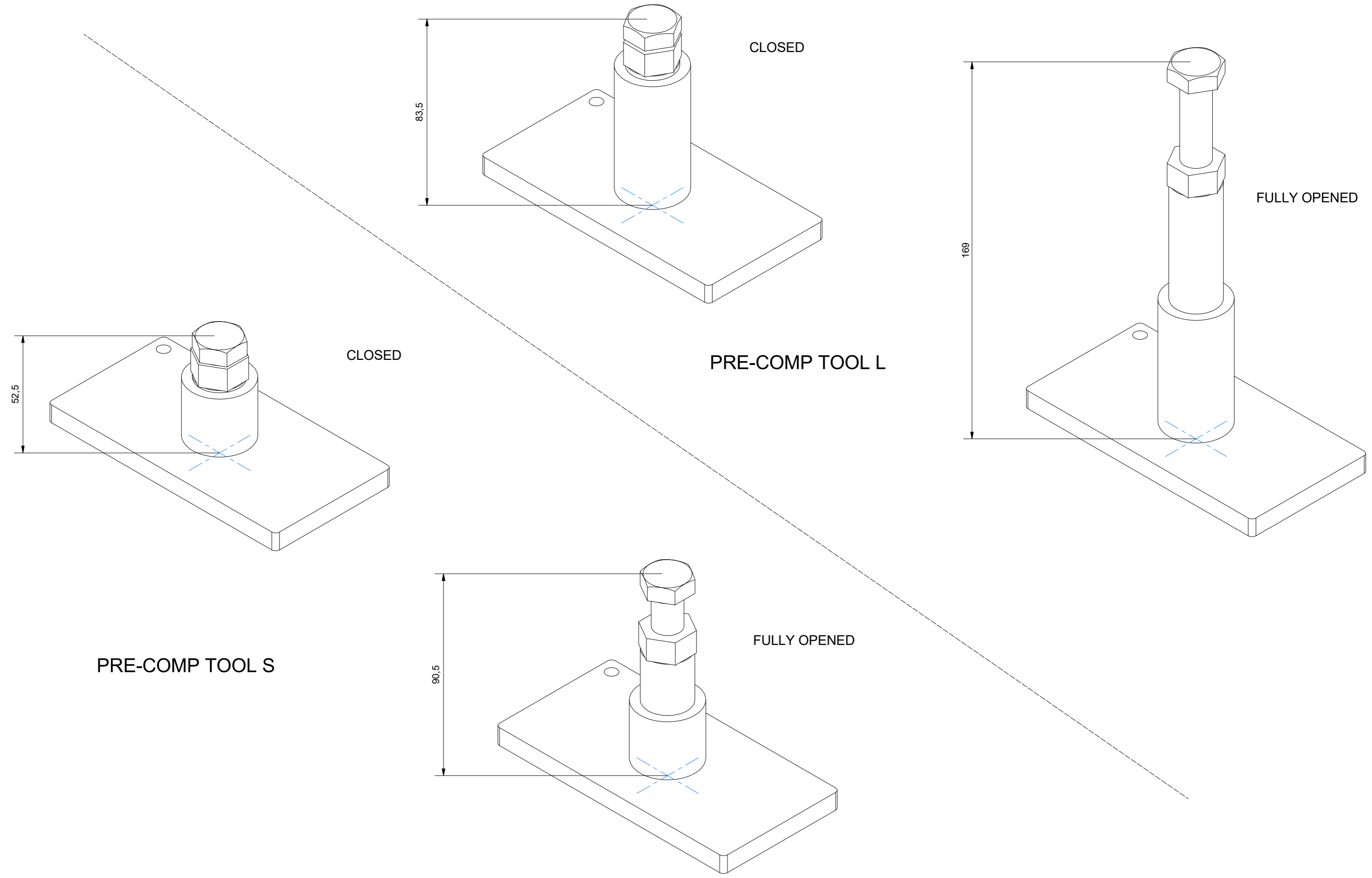

格克赛克保留所有权利。未经授权严禁复制，使用以及向第三方泄漏。

All rights reserved. Unauthorized reproduction, use or disclosure to third parties is strictly forbidden.

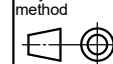

B		2018-03-16	se-robgus
Rev	Type of revision	Date	Sign

General tolerance: ISO 2768-1/2-m/K	Welded details: EN ISO 5817-B	General surface roughness: EN ISO 1302-BF	Designed by/date se-robgus 2018-02-21	Latest save date 2018-03-16	Format A2	Scale	Sheet no 1 / 1	TotWeight N/A
			Title PRE-COMP TOOL S/L ACCESSORIES		Restricted due to Information drawing		Drawing number S1530539	
www.roxtec.com								Projection method 
								Rev B