

格克赛克保留所有权利。未经授权严禁复制，使用以及向第三方泄漏。

All rights reserved. Unauthorized reproduction, use or disclosure to third parties is strictly forbidden.

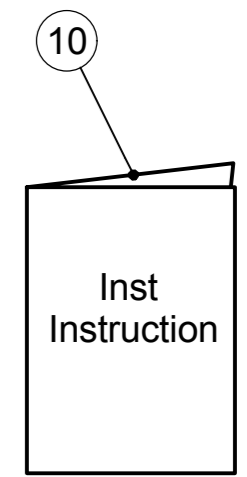
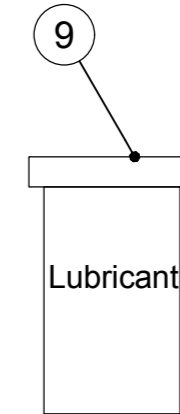
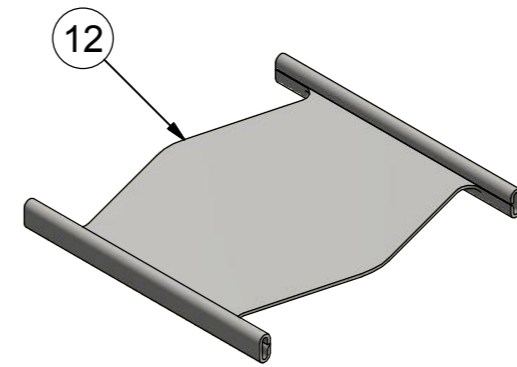
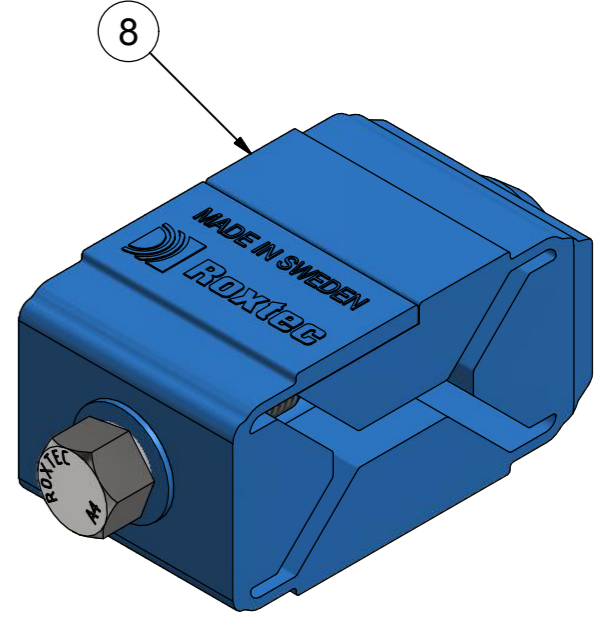
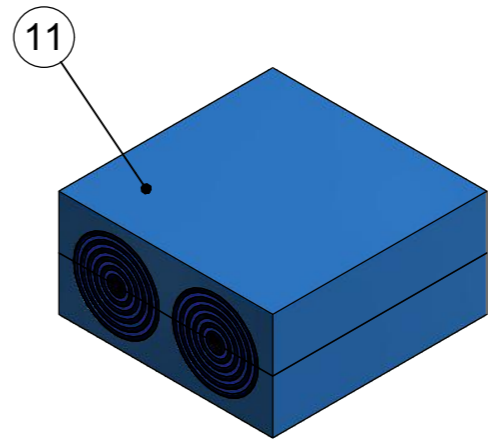
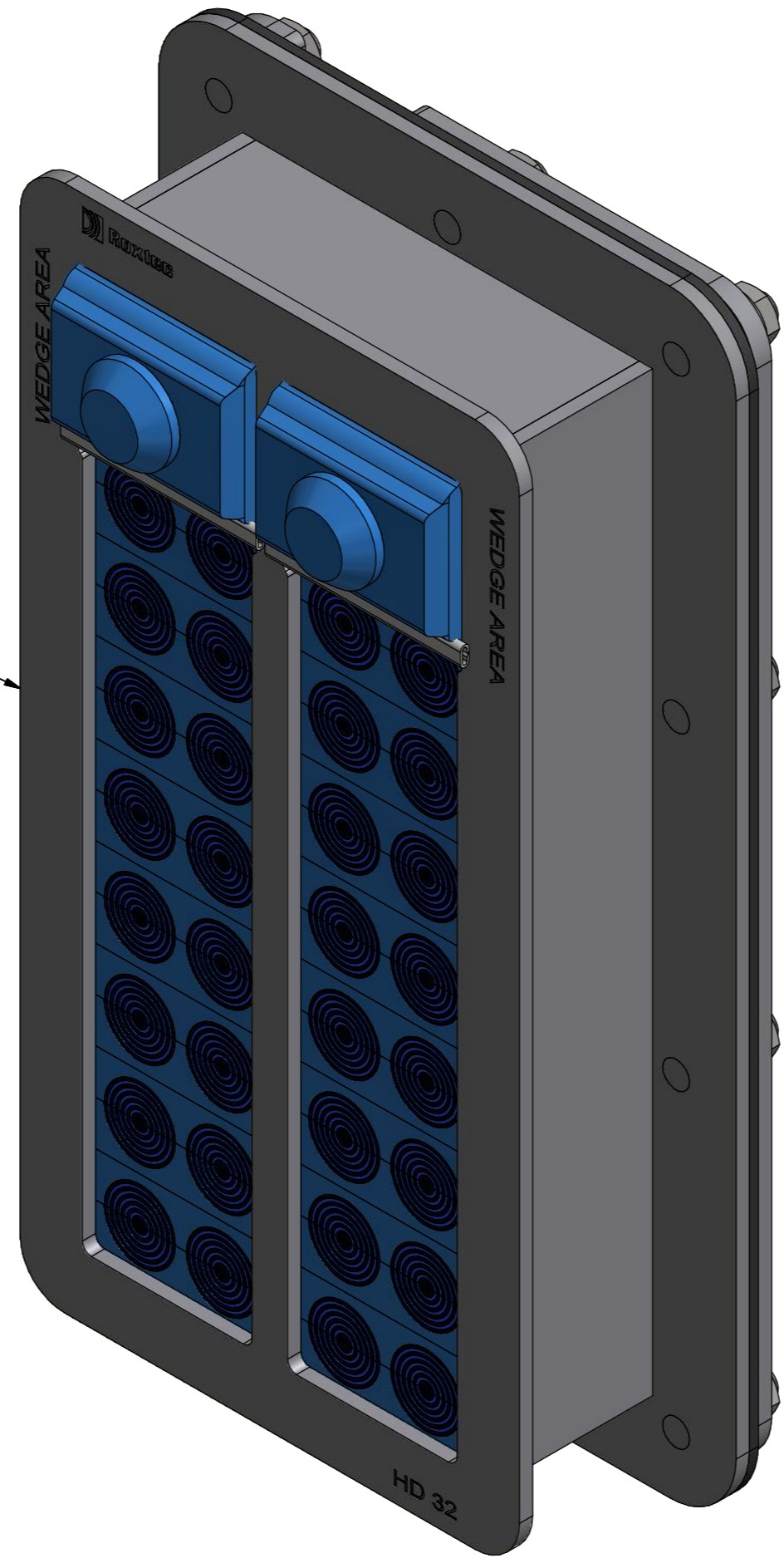
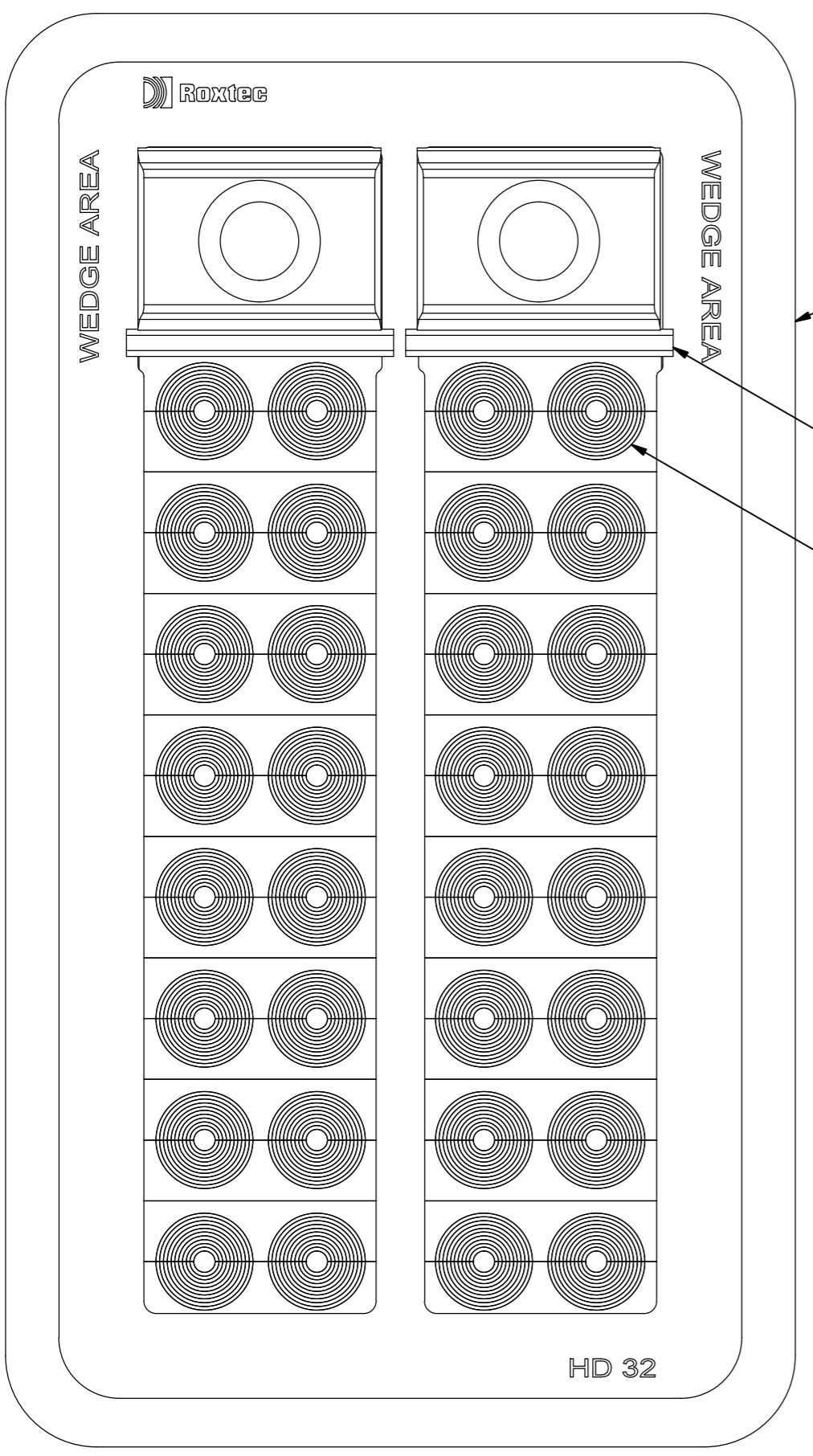
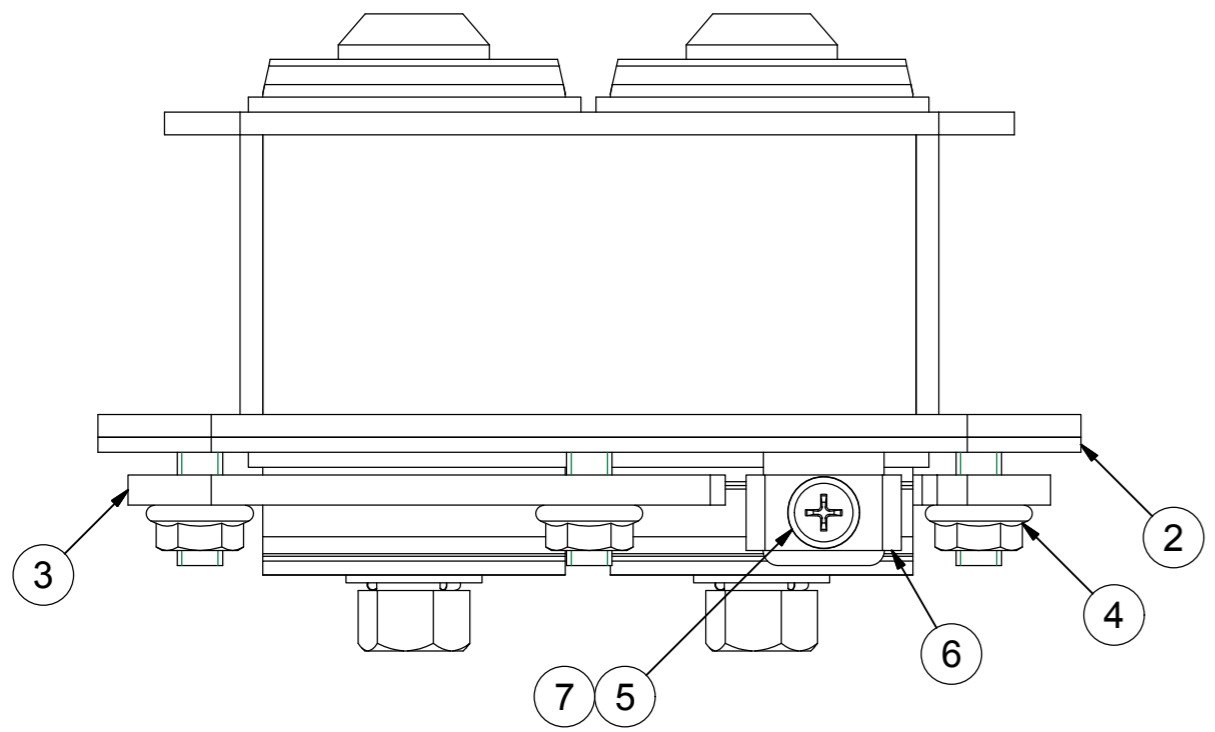

ITEM	QTY	Designation	Specification	Weight
12	2	STAYPLATE 40 HD	AISI 316L, t=0,5mm	
11	16	HD 20w40	RANGE $\varnothing$ 0+3.5-15.5	
10	1	INSTALLATION INSTRUCTION		
9	1	LUBRICANT	25 ml	
8	2	C WEDGE 40	AISI 316	
7	1	SPRING WASHER	M5, A4	
6	1	SADDLE WASHER	AISI 316	
5	1	SCREW	M5x10, A4	
4	10	FLANGED NUT	M6, A4	
3	2	COUNTER FRAME	AISI 316L	
2	1	GASKET	EPDM CELLULAR RUBBER	
1	1	HD 32 FRAME	AISI 316L	

General tolerance: ISO 2768-1/2-m/K EN ISO 13920-BF	Welded details: EN ISO 5817-B EN ISO 10042-B	General surface roughness: Ra 12.5	Designed by/date se-danstr 2016-05-30	Latest save date 2016-05-30	Format A2	Scale	Sheet no 1 / 1	TotWeight N/A
		<b>HD 32/32 ASSEMBLY</b>		Restricted due to Information drawing		Drawing number S1512984		Projection method 
www.roxtec.com			Title		Drawing number		Rev	
			HD 32/32 ASSEMBLY		S1512984		A	

A		2016-05-30	se-danstr
Rev	Type of revision	Date	Sign