

烙克赛克保留所有权利。未经授权严禁复制，使用以及向第三方泄漏。

Rev 2.0 All rights reserved. Unauthorized reproduction, use or disclosure to third parties is strictly forbidden.

VERSION A

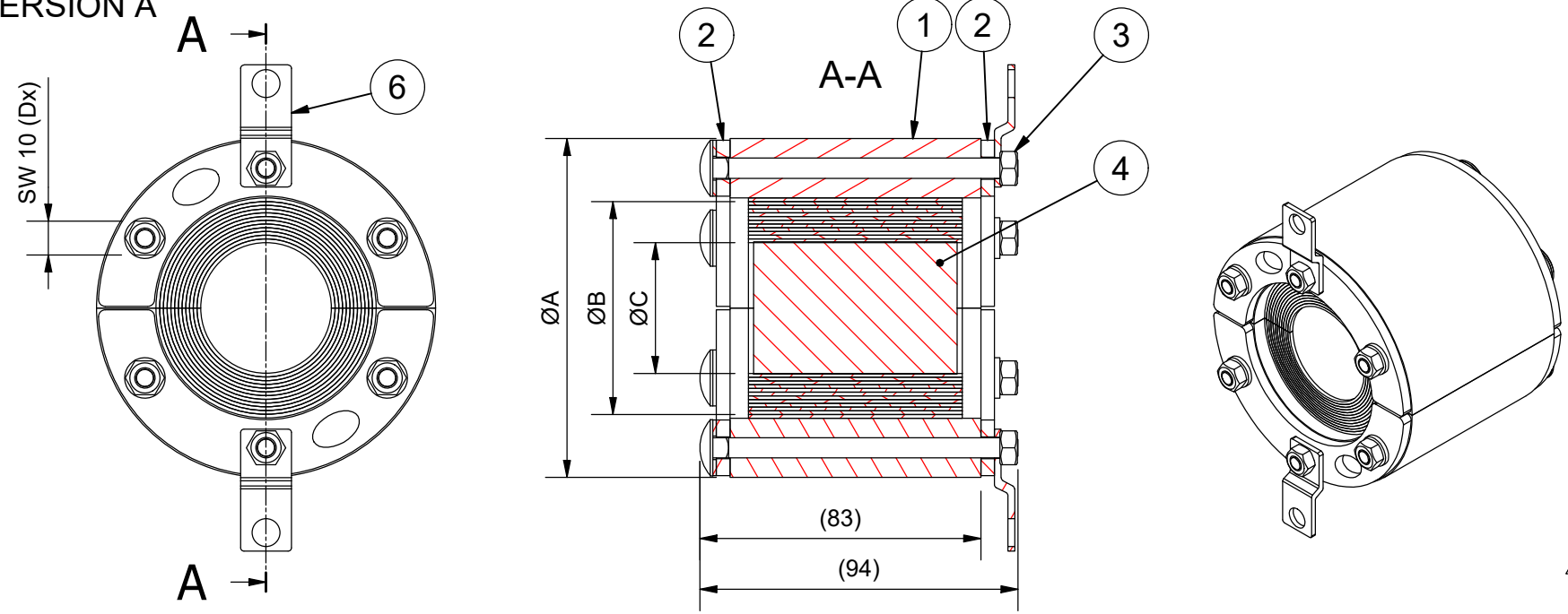

PRODUCT	APERTURE A (MM)	RANGE C-B (MM)	D (QTY)	E (QTY)	VER.	T (MM)
RS 70 UG	70-75	9-33	4	2	A	-
RS 75 UG	75-80	9-33	4	2	B	2.5
RS 80 UG	80-85	9-33	4	2	B	5
RS 90 UG	90-95	24-53	6	2	A	-
RS 95 UG	95-100	24-53	6	2	B	2.5
RS 100 (4") 24-53 UG	100-105	24-53	6	2	B	5
RS 100 (4") UG	100-105	39-63	6	2	A	-
RS 105 UG	105-110	39-63	6	2	B	2.5
RS 110 UG	110-115	39-63	6	2	B	5
RS 125 (5") UG	125-130	55-88	6	2	A	-
RS 130 UG	130-135	55-88	6	2	B	2.5
RS 135 55-88 UG	135-140	55-88	6	2	B	5
RS 135 UG	135-140	65-98	6	2	A	-
RS 140 UG	140-145	65-98	6	2	B	2.5
RS 145 UG	145-150	65-98	6	2	B	5
RS 150 UG	150-155	80-113	8	4	A	-
RS 155 UG	155-160	80-113	8	4	B	2.5
RS 160 UG	160-165	80-113	8	4	B	5
RS 185 UG	185-190	114-148	8	4	A	-
RS 190 UG	190-195	114-148	8	4	B	2.5
RS 195 UG	195-200	114-148	8	4	B	5

VERSION B

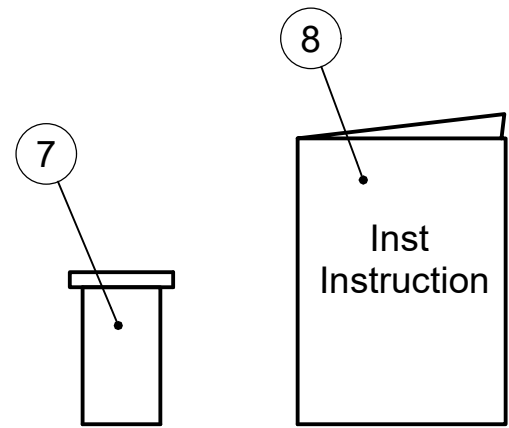
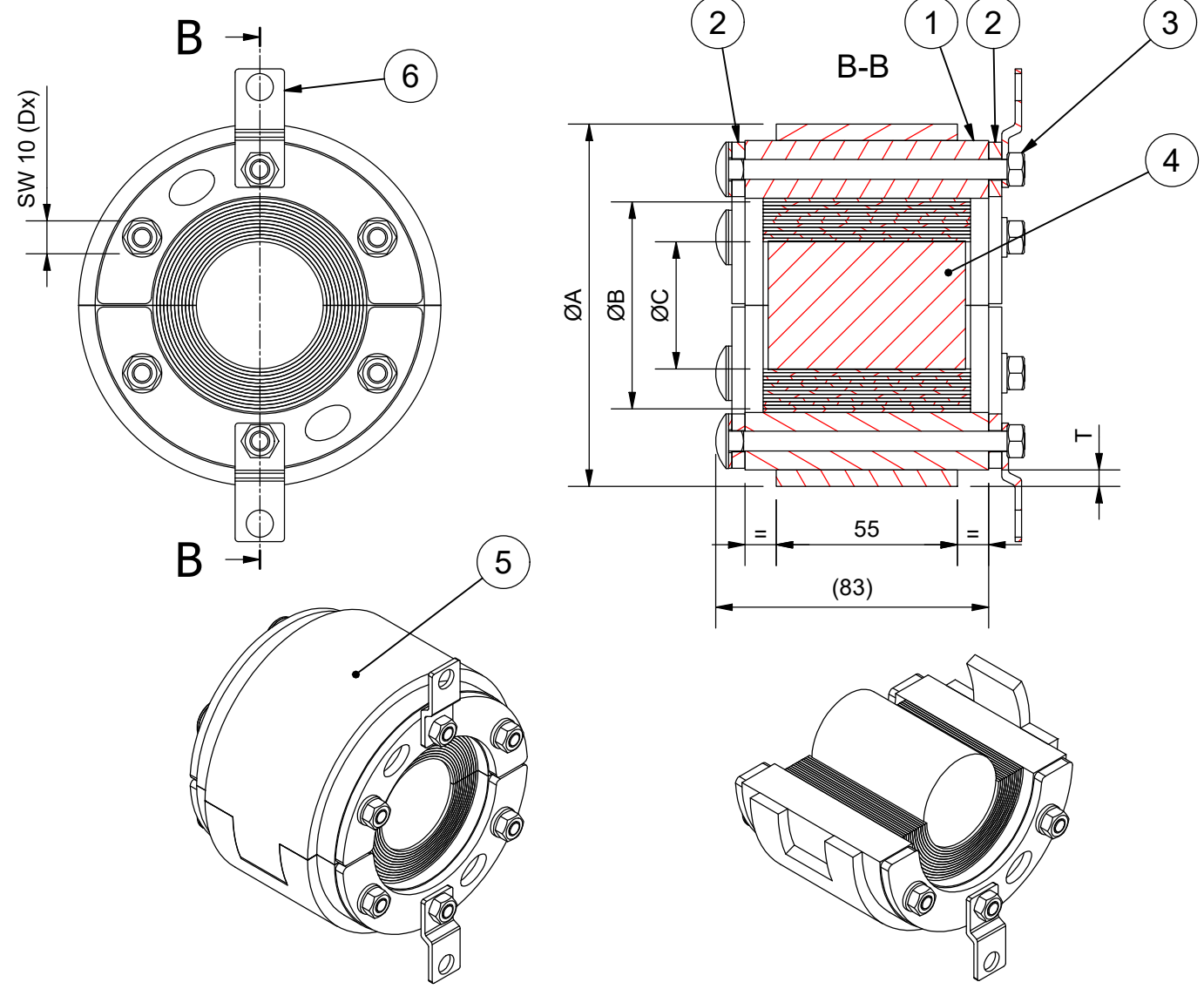

WOC VERSION IS WITHOUT CENTER CORE

ITEM	QTY	Designation	Specification	Weight
8	1	INSTALLATION INSTRUCTION		
7	1	LUBRICANT	TALLOW	
6	E	STOP FLANGE	A4	
5	2	OUTER DIAMETER EXTENSION	ROXYLON (NOT ON VERSION A)	
4	1	CORE	ROXYLON (NOT IN WOC VERSIONS)	
3	D	FASTENERS	M6 A4	
2	4	FITTING	ACID PROOF STAINLESS STEEL	
1	2	RUBBER FRAME	ROXYLON	

General tolerances used for manufacturing shown in document DOC-002180		Designed by/date se-ronpet 2016-04-15	Latest save date 2023-01-24	Format A3	Scale	Sheet no 1 / 1	TotWeight 0,8 kg
		Title RS UG SEALING RS 70-195 UG		Projection method 		Rev H	
www.roxtec.com		Restricted due to Information drawing		Drawing number S1511690			

H	TABLE UPDATED.	2023-01-18	se-larlar
Rev	Type of revision	Date	Sign

Information drawings show general design and nominal dimensions if not else stated