

洛克赛克保留所有权利。未经授权严禁复制，使用以及向第三方泄漏。

All rights reserved. Unauthorized reproduction, use or disclosure to third parties is strictly forbidden.

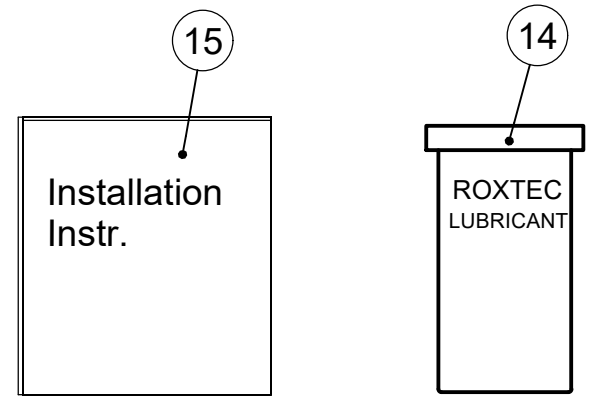
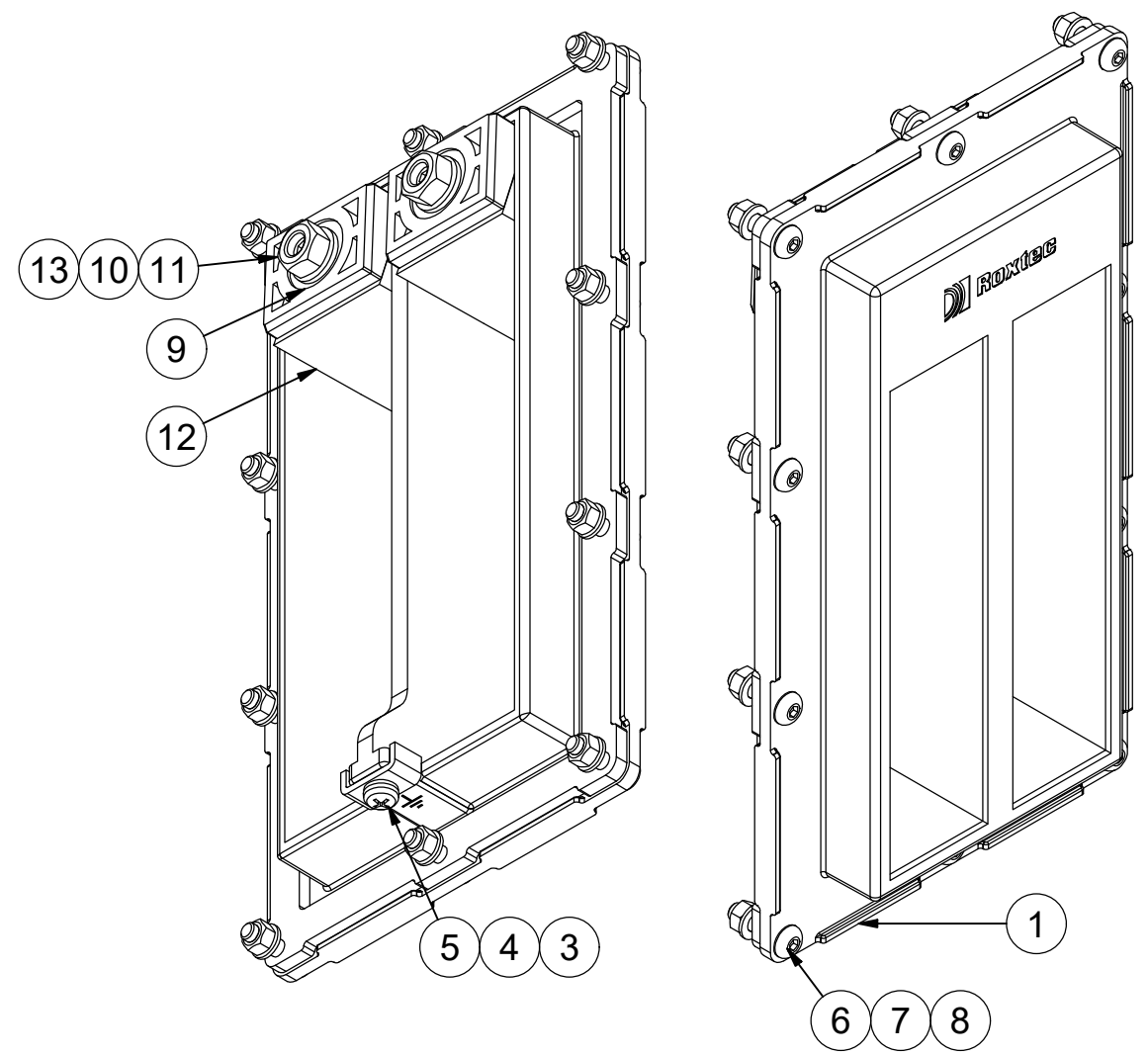
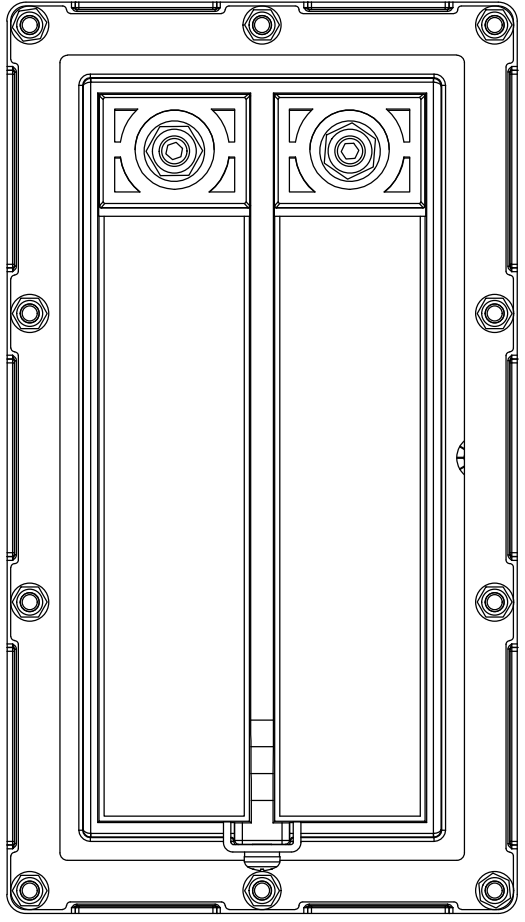
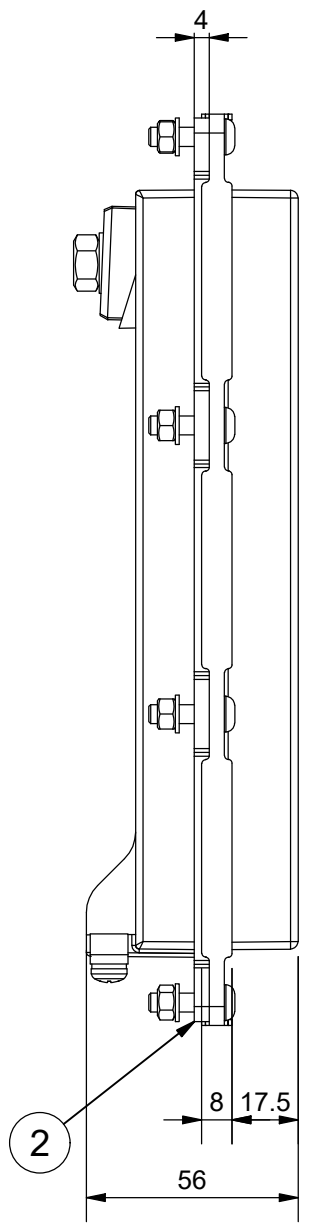
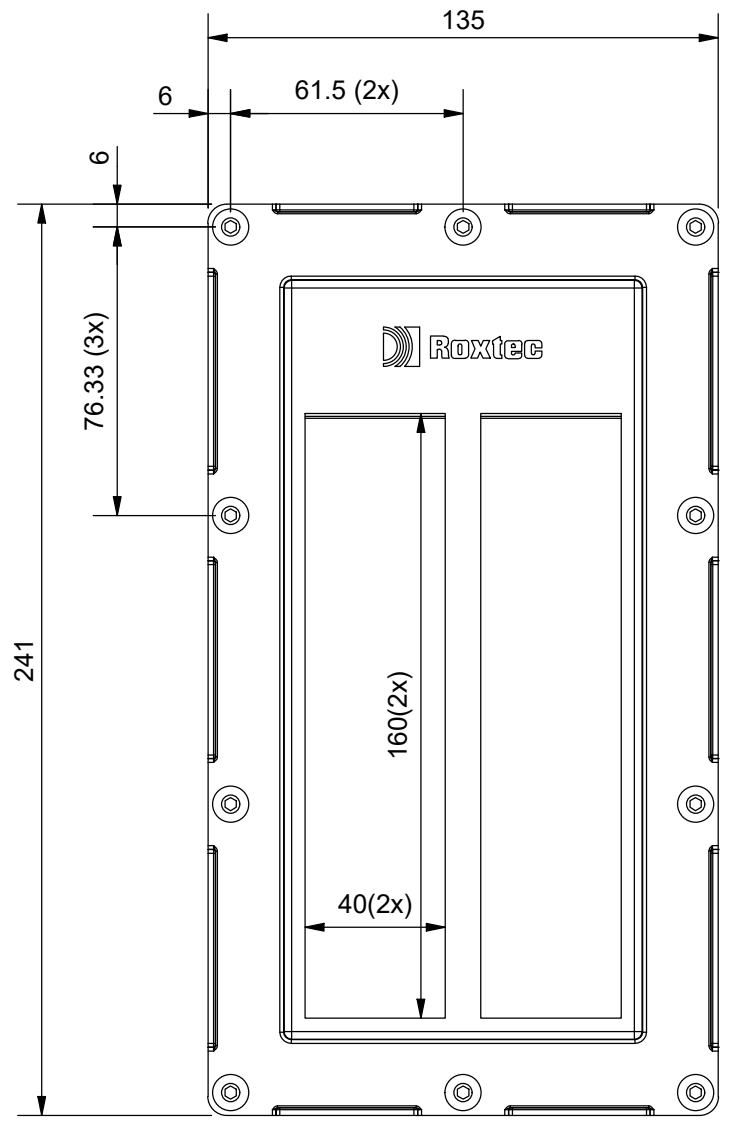

ITEM	QTY	Designation	Specification	Weight
15	1	INSTALLATION INSTRUCTION		
14	1	LUBRICANT		
13	2	SET SCREW	SK6SS M8x50 A4	0
12	2	COMPRESSION WEDGE	ROXYLON	0
11	2	NUT	M6M M8 ISO 4032 A4	0
10	2	WASHER	BRB M8 ISO 7089 A4	0
9	2	BOTTOM PLATE	PA 6.6	0
8	10	NUT	M6M M5 ISO 4032 A4	0
7	10	WASHER	M5 140HV DIN 125 A4	0
6	10	SCREW	K6S M5x20 A4-70	0
5	1	SCREW	M5x10 DIN 7985-H A4, GREEN ZINC-PLATED	0
4	1	SPRING WASHER	5,1x9,2x1,2 DIN 127-B A4, GREEN ZINC-PLATED	0
3	1	SADDLE WASHER	AISI 316	0
2	1	GASKET	CELLUAR RUBBER	0.2
1	1	FRAME	COMSEAL 32 BG FRAME	0.6

F

F	TABLE UPDATED	2024-01-30	se-mikgru
Rev	Type of revision	Date	Sign

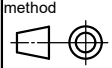
General tolerance: ISO 2768-1/2-m/K EN ISO 13920-BF	Welded details: EN ISO 5817-B EN ISO 10042-B	General surface roughness: Ra 12.5	Designed by/date se-almah 2015-11-17	Latest save date 2024-02-14	Format A3	Scale	Sheet no 1 / 1	TotWeight N/A
 <a href="http://www.roxtec.com">www.roxtec.com</a>			Title COMSEAL 32 BG		Projection method			
			Restricted due to Information drawing		Drawing number S1508056			