

VERSIONS:
 H3 INSERTABLE
 H3 INSERTABLE WOC

TYPE	CABLE/PIPE Ø (MM)	Ø A (MM)	Ø B (MM)	Ø APERTURE (MM)
H3 150	24-54	150	160	150-152
H3 150 WOC	24-54	150	160	150-152
H3 150 INSERTABLE	24-54	150	-	150-152
H3 150 INSERTABLEWOC	24-54	150	-	150-152
H3 200	48-70	200	210	200-202
H3 200 WOC	48-70	200	210	200-202
H3 200 INSERTABLE	48-70	200	-	200-202
H3 200 INSERTABLE WOC	48-70	200	-	200-202

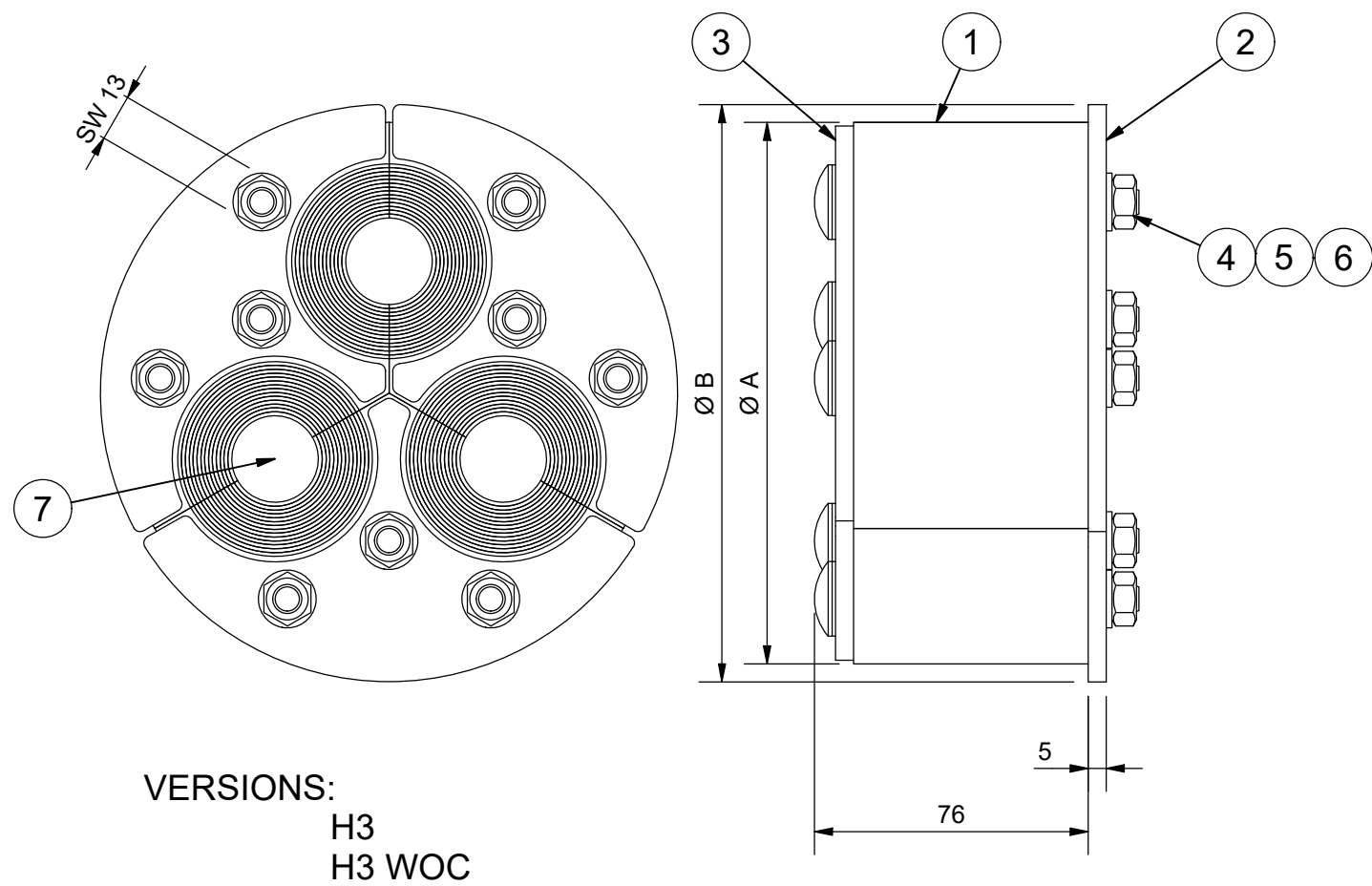

VERSIONS:
 H3
 H3 WOC

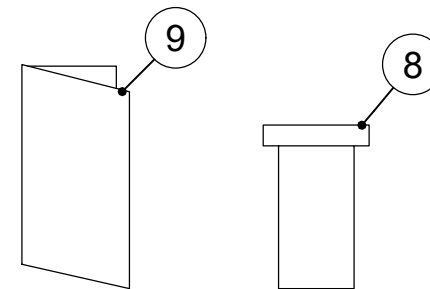

B

NOTE: WOC VERSIONS IS WITHOUT CORE

ITEM	QTY	Designation	Specification	Weight
9	1	INSTALLATION INSTRUCTION		
8	1	LUBRICANT	TALLOW	
7	3	CORE	ROXYLON	
6	9	NUT	M8 A4	
5	9	WASHER	M8 A4	
4	9	SCREW	MVBF M8x85 A4	
3	6	REAR FITTING	ACID PROOF STAINLESS STEEL	
2	6	FRONT FITTING	ACID PROOF STAINLESS STEEL	
1	3	RUBBER FRAME	ROXYLON	

General tolerances used for manufacturing shown in document DOC-002180		Designed by/date se-ronpet 2014-05-19	Latest save date 2021-07-01	Format A3	Scale	Sheet no 1 / 1	TotWeight N/A
Roxtec www.roxtec.com		Title H3 SEAL H3 150-200		Projection method 		Rev B	
		Restricted due to Information drawing		Drawing number S1039325			

B	TABLE UPDATED.	2021-07-01	se-jenboh
Rev	Type of revision	Date	Sign