

R150 UG FRAME

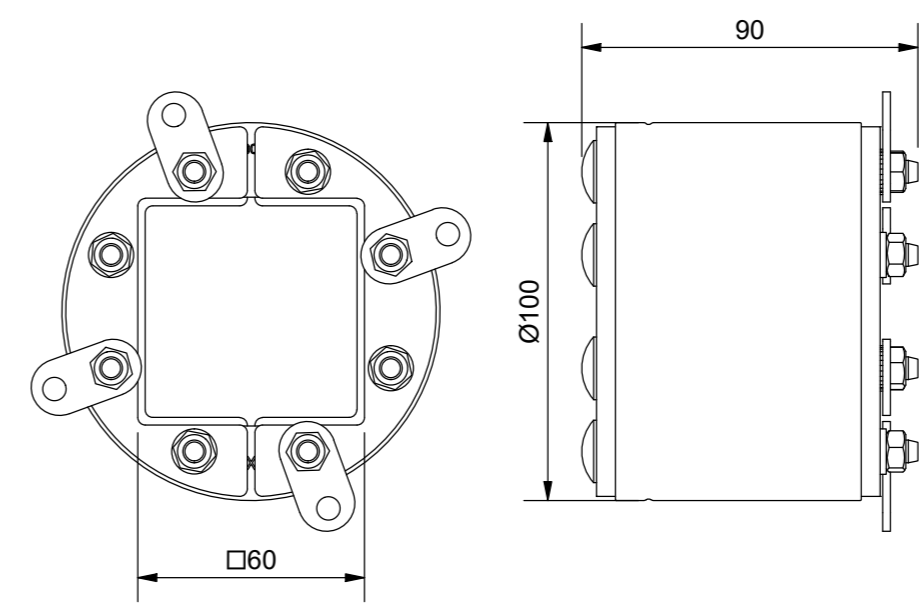

R100 UG FRAME

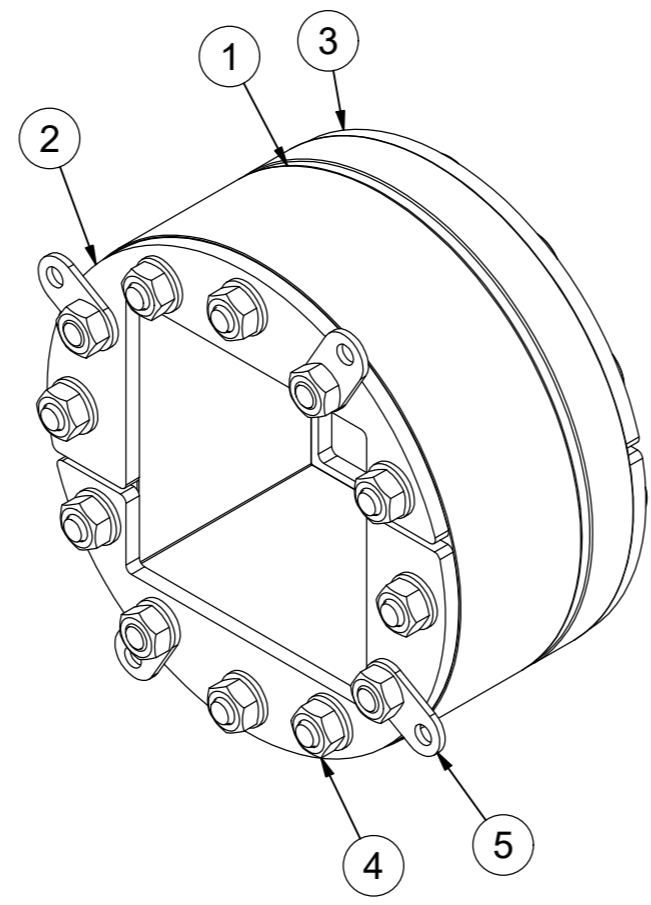
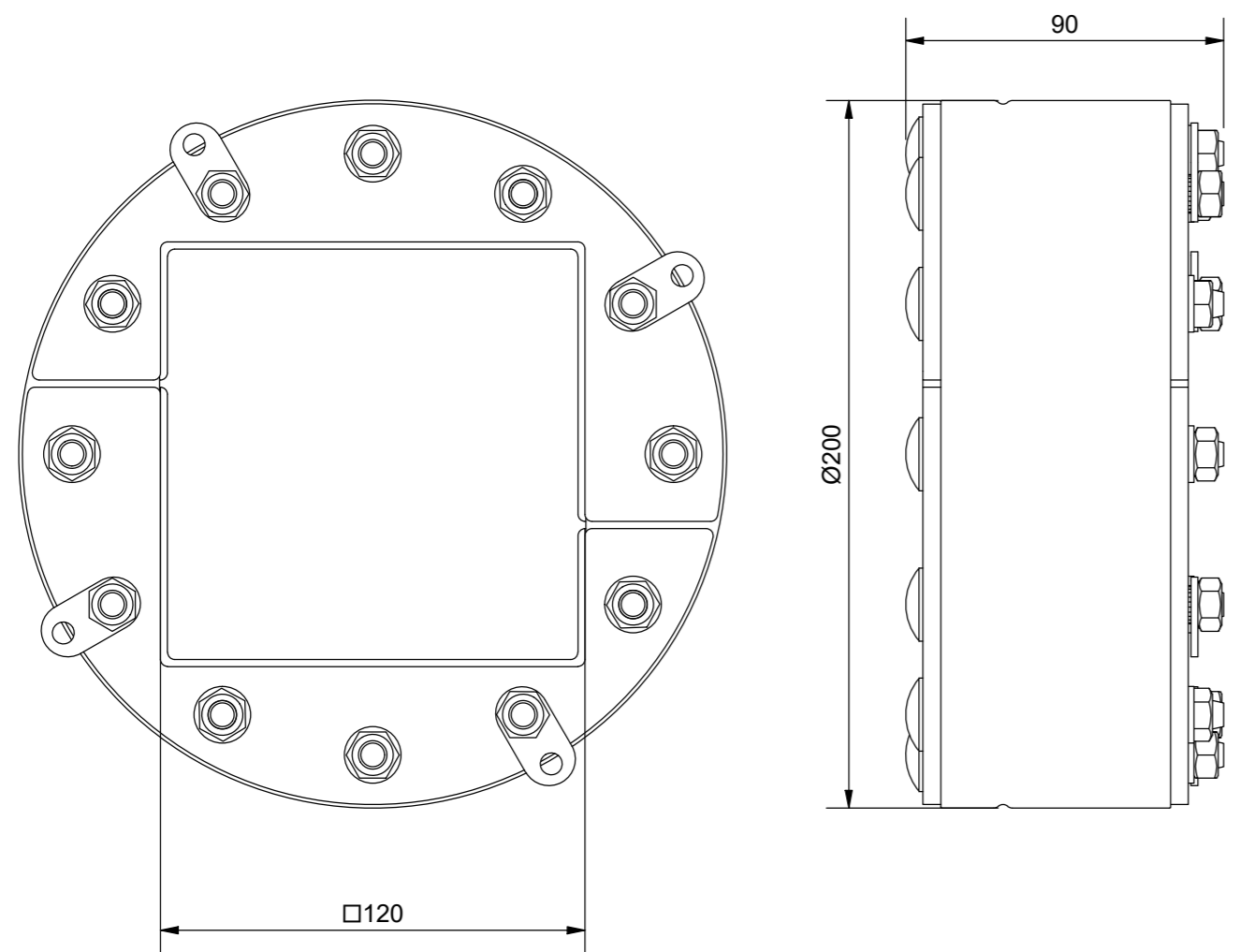
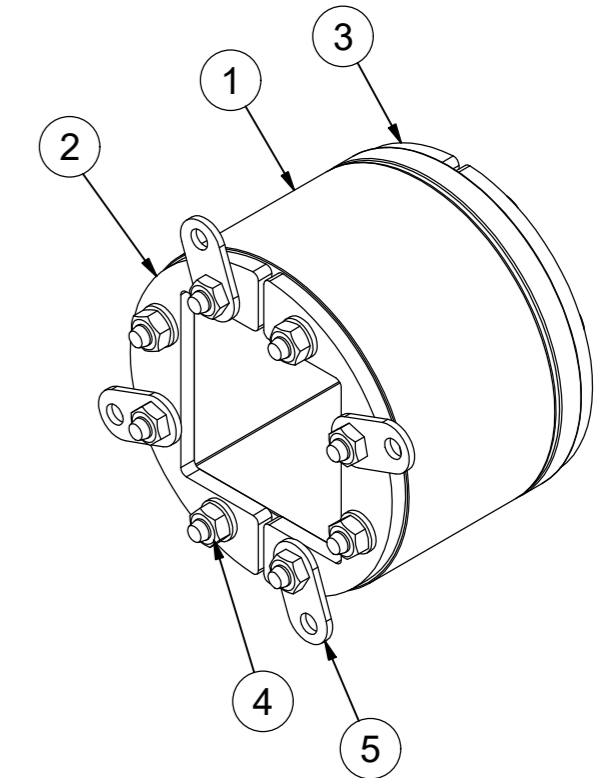

R200 UG FRAME

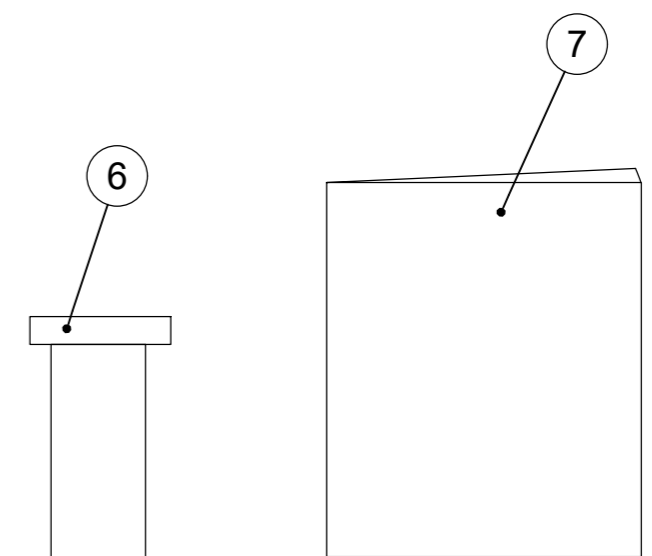
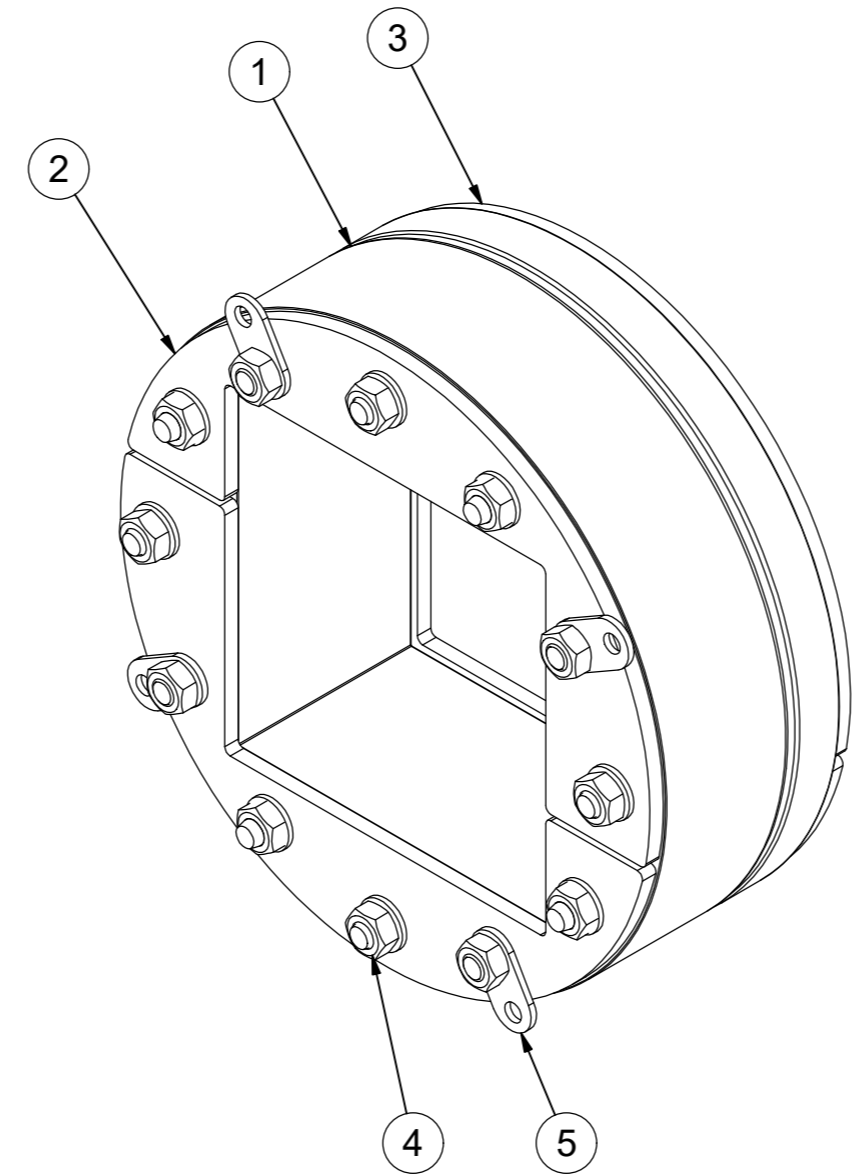

LUBRICANT AND INSTALLATION INSTRUCTION INCLUDED

7	1	INSTALLATION INSTRUCTION							
6	1	LUBRICANT	TALLOW 25ML						
5	4	STOP FLANGE	ACID PROOF STAINLESS STEEL						
4	-	FASTENERS	ACID PROOF STAINLESS STEEL						
3	2	REAR FITTING	ACID PROOF STAINLESS STEEL						
2	2	FRONT FITTING	ACID PROOF STAINLESS STEEL						
1	1	RUBBER FRAME	ROXYLON HE						
ITEM	QTY	Designation	Specification				Weight		
General tolerances used for manufacturing shown in document DOC-002180		Designed by/date se-jenboh 2013-09-13	Latest save date 2020-03-19	Format A2	Scale	Sheet no 1 / 1	TotWeight N/A		
Title R UG SERIES R100 - R200 UG FRAMES		Restricted due to Information drawing		Drawing number S1035437		Rev I	Projection method ⊕		

I	ADD STOP FLANGES	2020-03-19	se-henols
Rev	Type of revision	Date	Sign