

烙克赛克保留所有权利。未经授权严禁复制，使用以及向第三方泄露。

TYPE	CALBLE/PIPE Ø (A-B) [mm]	H [mm]	W [mm]	C [QTY]
RM 20 UG	4 - 13	20	20	1
RM 20w40 UG	4 - 13	20	40	2
RM 30 UG	10 - 23.5	30	30	1
RM 40 UG	9.5 - 31	40	40	1
RM 60 UG	24 - 52	60	60	1
RM 80 UG*	48 - 68	80	80	1
RM 90 UG*	48 - 68	90	90	1
RM 120 UG WOC	67.5 - 96	120	120	0

*ALSO AVAILABLE IN WOC VERSION DELIVERED WITHOUT CORE

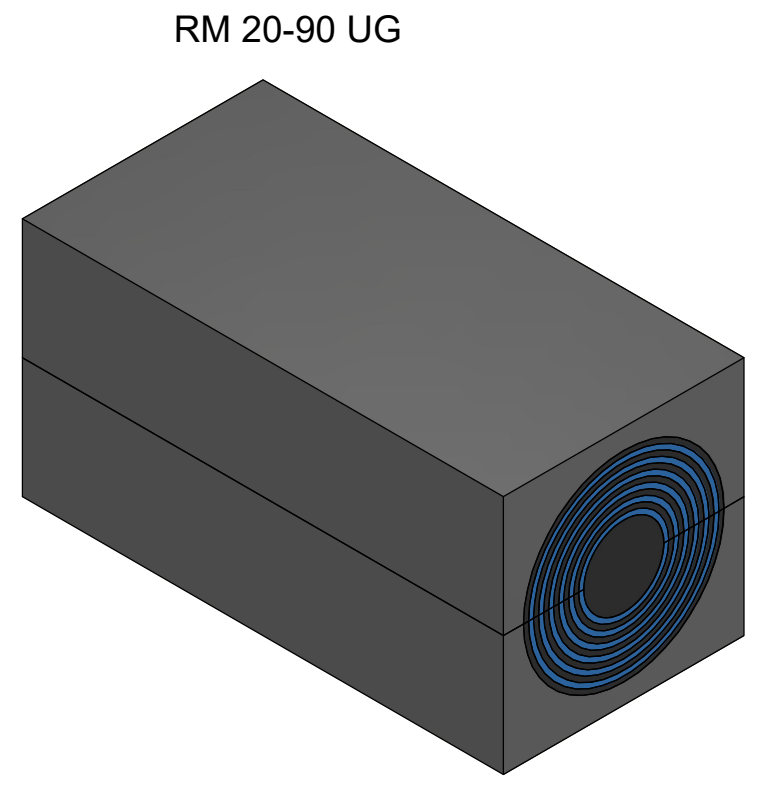
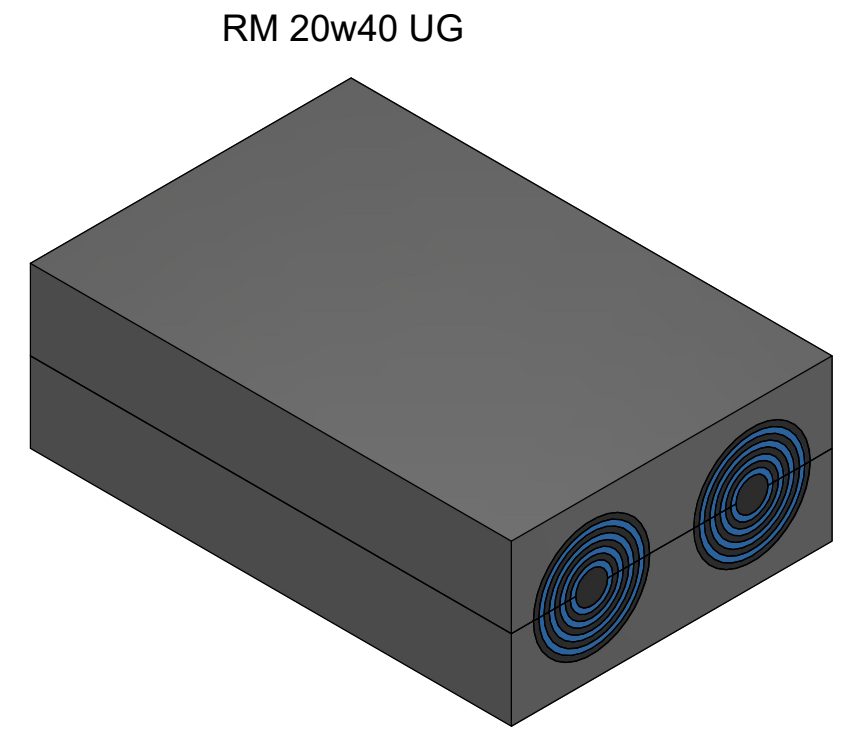
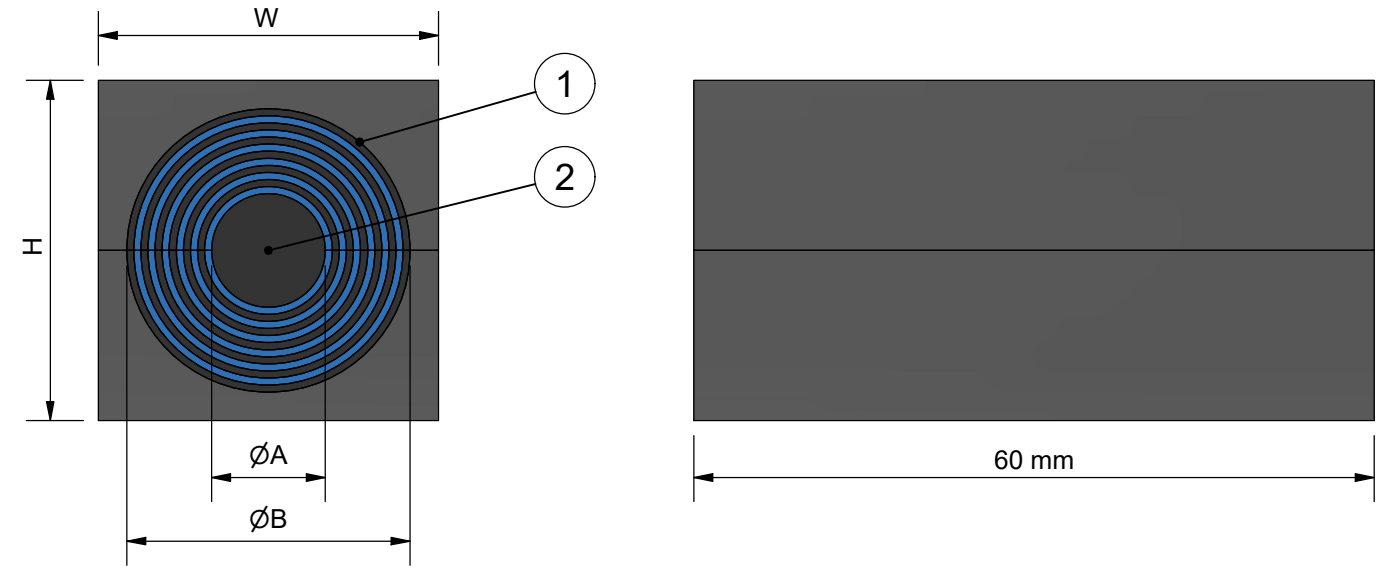

MODULE HALVES WITH CORE

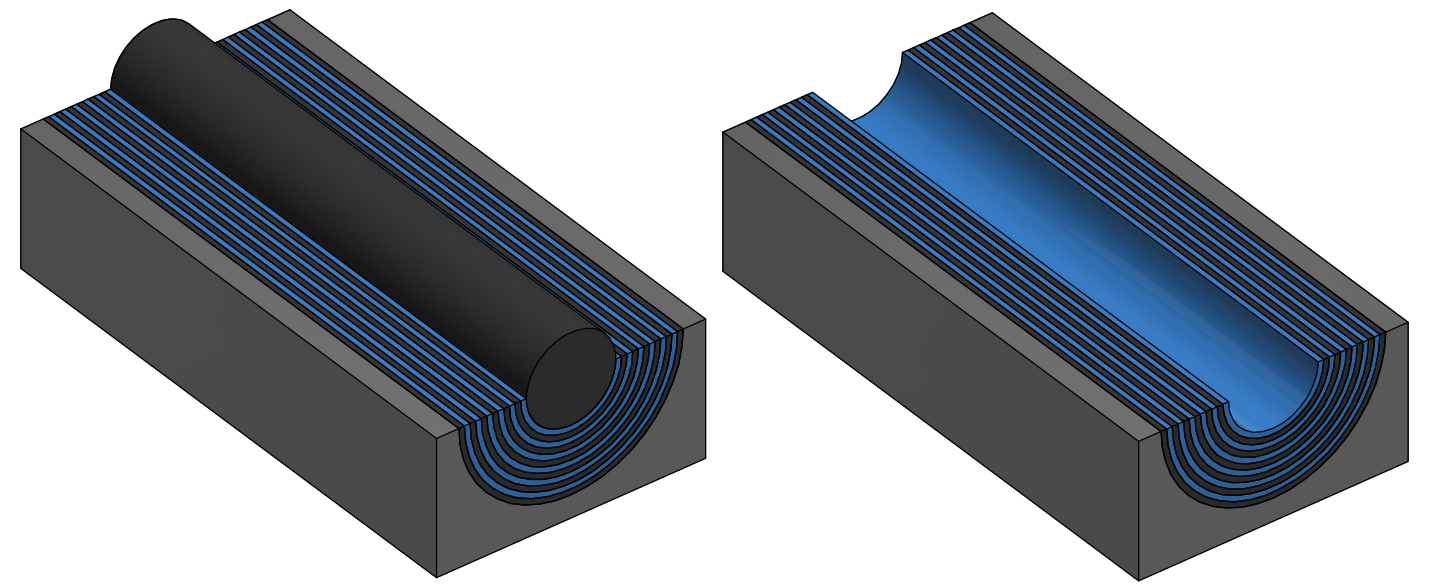

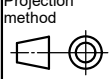
2	C	CORE	ROXYLON					
1	2	RUBBER PROFILE	ROXYLON					
ITEM	QTY	Designation	Specification				Weight	
General tolerances used for manufacturing shown in document DOC-002180		Designed by/date se-jenboh 2013-09-04	Latest save date 2024-08-12	Format A3	Scale	Sheet no 1 / 1	TotWeight	
 www.roxtec.com		Title RM UG MODULES ASSEMBLY				Projection method 		
		Restricted due to Information drawing		Drawing number S1035179		Rev E		

E	TABLE UPDATED	2024-08-12	se-marfre
Rev	Type of revision	Date	Sign

Information drawings show general design and nominal dimensions if not else stated

Rev 3.1 All rights reserved. Unauthorized reproduction, use or disclosure to third parties is strictly forbidden.