

RANGE: 3x48-68mm [1,89-2,68 \"]

(Ø200 [7,874\"/>

(Ø210 [8,268\"/>

(65 [2,559\"/>

ALLEN KEY  
SW 6mm

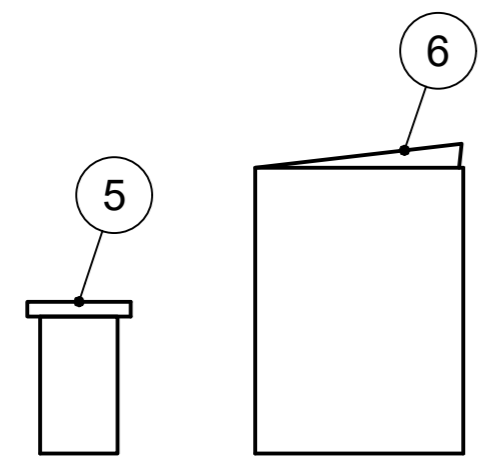
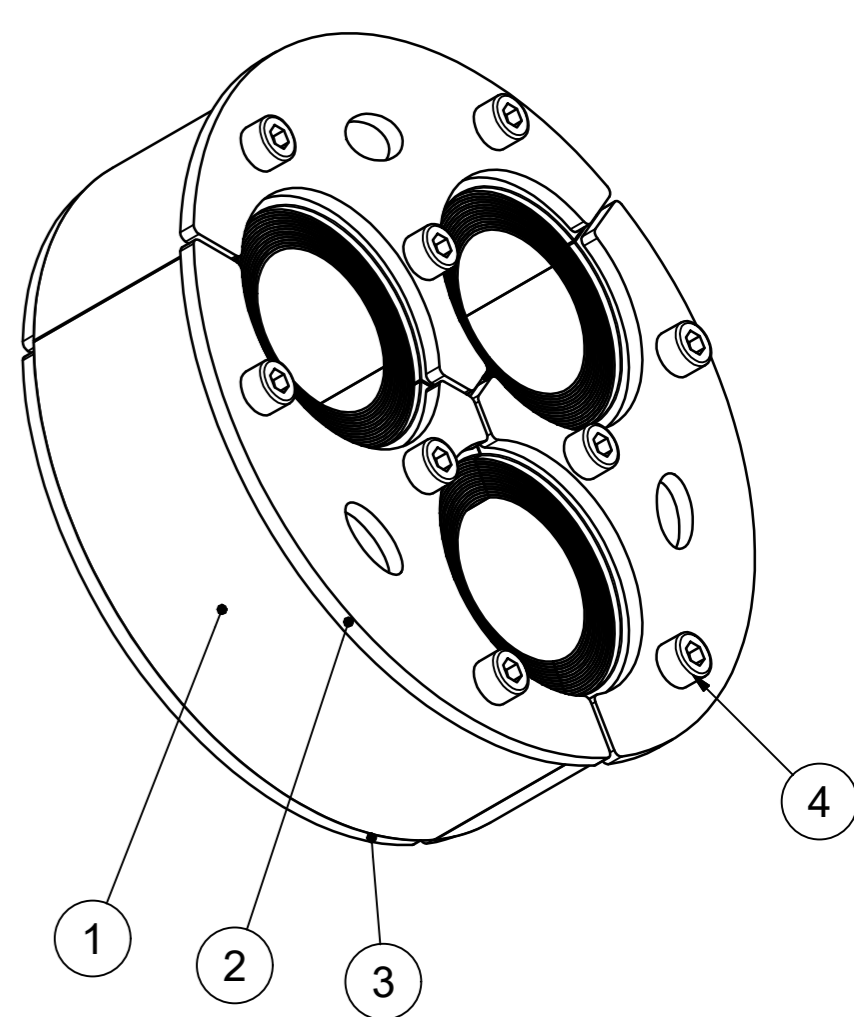

NOTE:  
WOC VERSION IS WITHOUT  
CENTERCORES



ITE	QTY	Designation	Specification	Weight
7	3	CENTER CORE	NOT IN WOC VERSIONS	
6	1	INSTALLATION INSTRUCTION		
5	1	LUBRICANT	10ml	
4	9	SCREW	ISO 4762 M8x70 A4	
3	3	REAR FITTING	AISI 316 T=5mm	
2	3	FRONT FITTING	AISI 316 T=5mm	
1	3	RUBBER FRAME	ROXYLON HE	

General tolerance:		Welded details:		General surface roughness:		Designation		Specification		Weight	
ISO 2768-1/2-m/K	EN ISO 13260-BF	EN ISO 5817-B	EN ISO 10042-B	Re 12.5	se-jenboh	2013-06-24	2018-06-26	A2	1 / 1	N/A	

<b>Roxtec</b>	<b>H3-200 UG ASSEMBLY</b>	Projection method
www.roxtec.com	Restricted due to Information drawing	⊕
Drawing number		Rev
S1033803		C

Rev	Type of revision	Date	Sign
C	MATERIAL ADD, TITLE BLOCK CORRECTED	2018-08-13	se-henols