

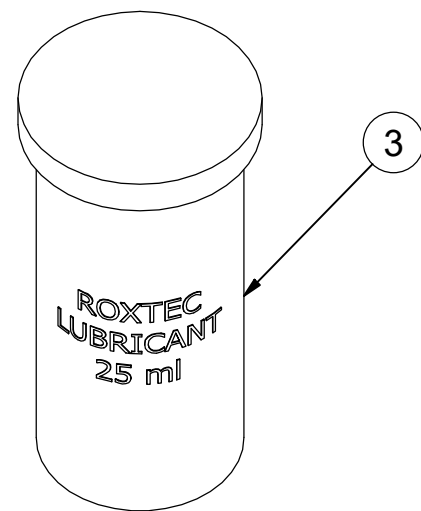

GALVANIZED OR STAINLESS STEEL

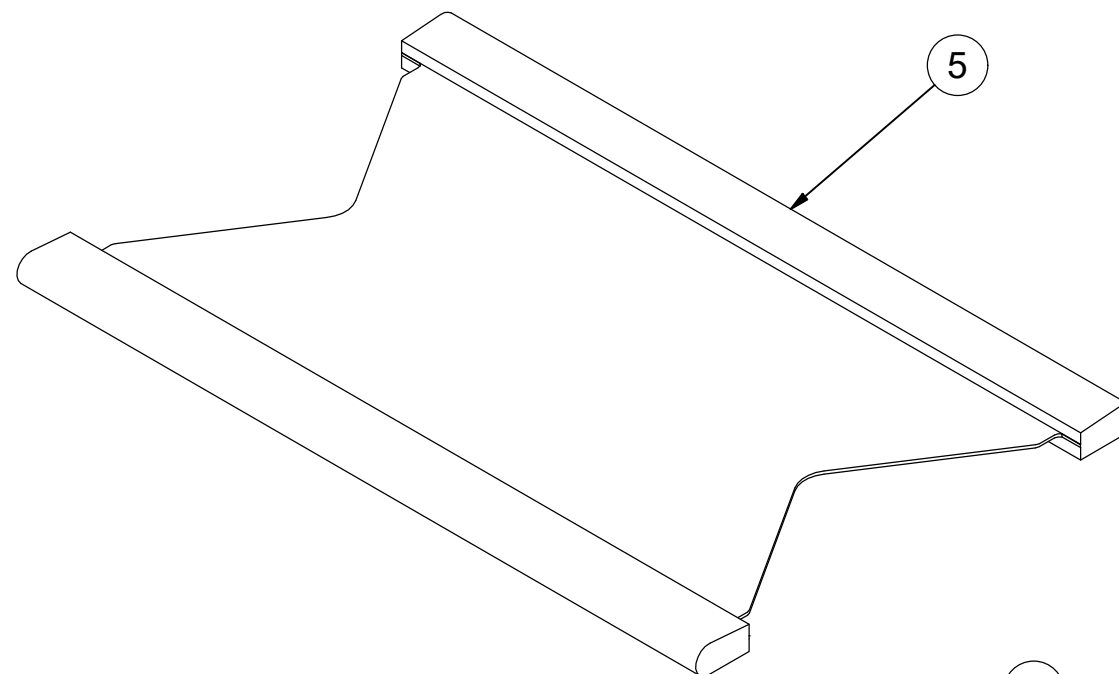
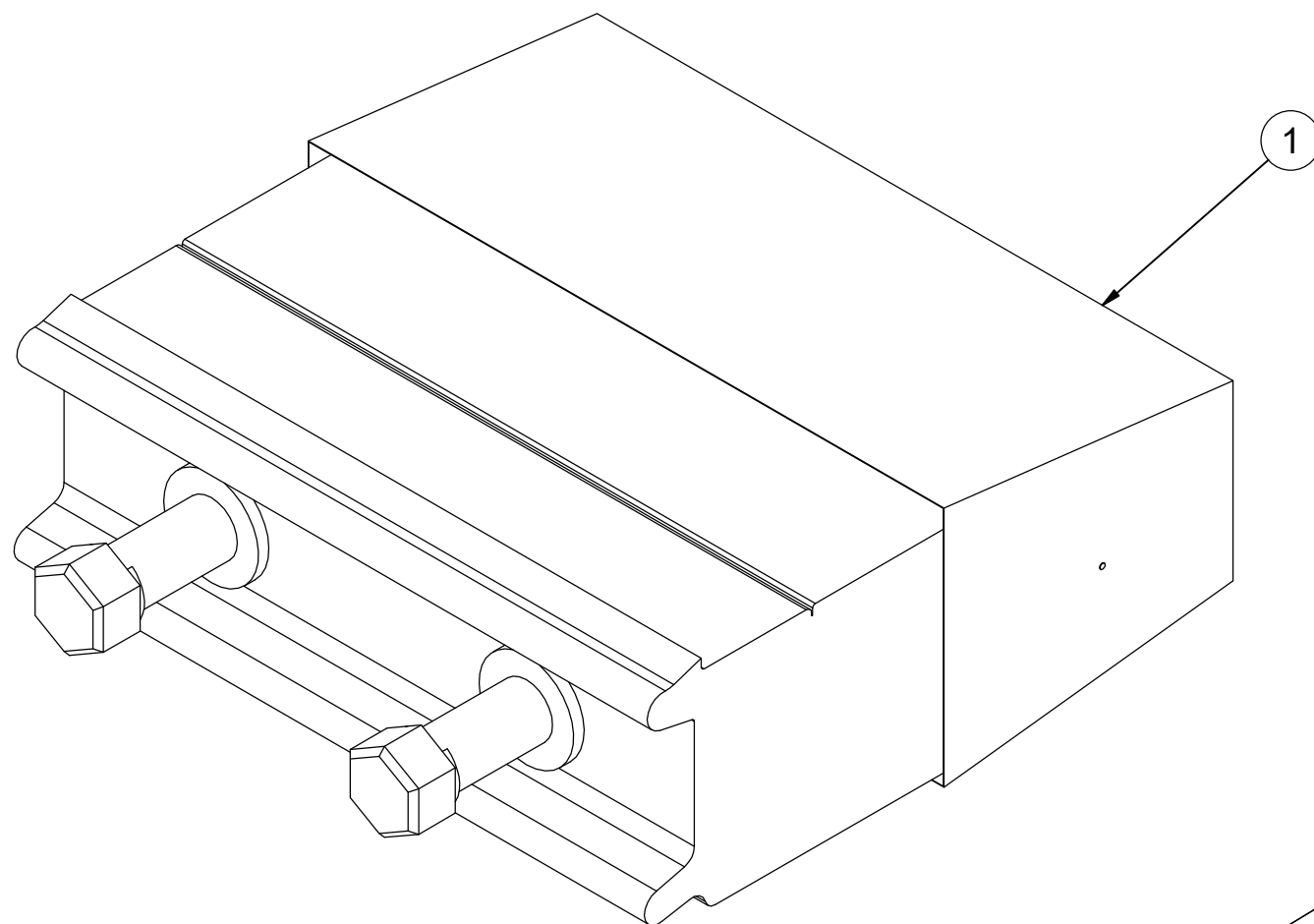

ITEM	QTY	Designation	Specification	Weight
5	5	STAYPLATE		
4	1	INSTALLATION INSTRUCTION		
3	1	LUBRICANT	25ml	
2	1	ROXTEC WEDGE CLIP		
1	1	ROXTEC WEDGE ES		

General tolerances used for manufacturing shown in document DOC-002180		Designed by/date se-jenboh 2011-03-21	Latest save date 2020-11-24	Format A3	Scale	Sheet no 1 / 1	TotWeight 0,4 kg
 www.roxtec.com		Title ROXTEC WEDGEKIT ES ASSEMBLY				Projection method 	
		Restricted due to Information drawing		Drawing number S1023256		Rev B	

B	CHANGED EMC TO ES IN PARTS LIST	2020-11-24	se-mikgru
Rev	Type of revision	Date	Sign