

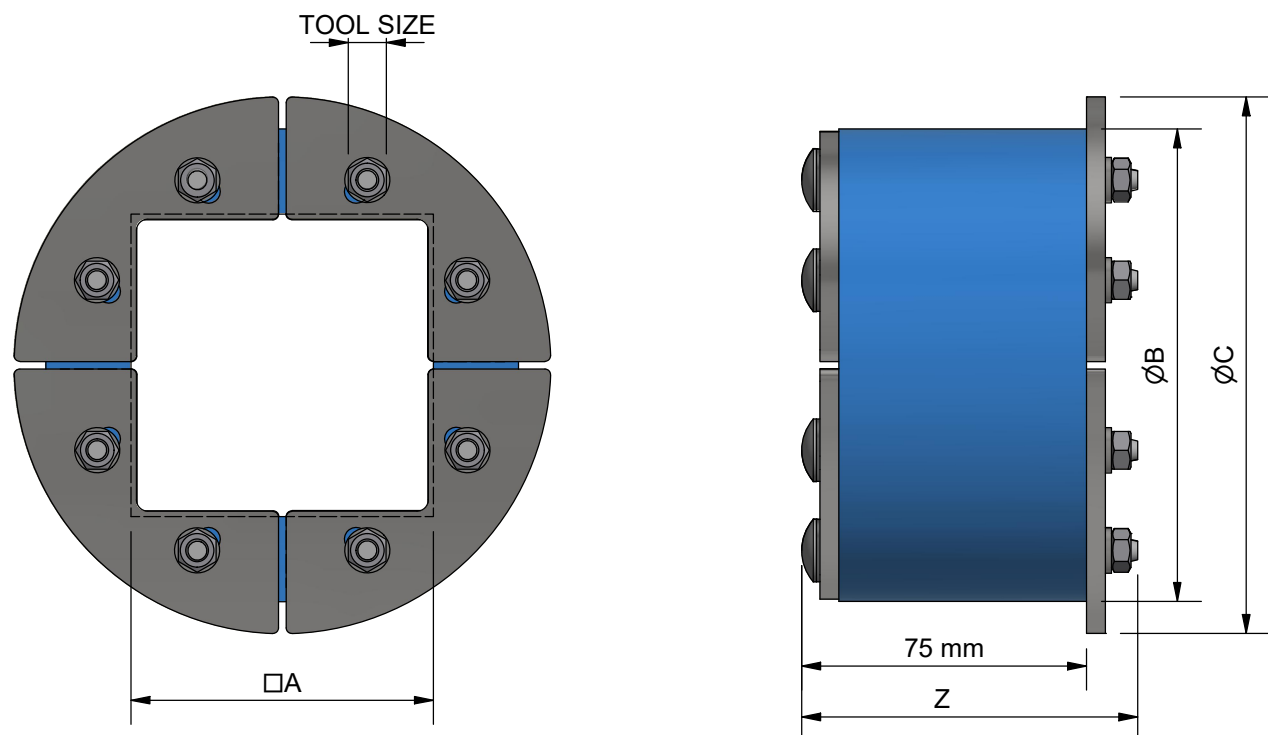

TYPE	A [mm]	B [mm]	C [mm]	Z [mm]	TOOL SIZE [mm]	S [QTY]	W, N & G [QTY]
R 70 Ex	40	70	85	85	10	4	4
R 75 Ex	40	75	85	85	10	4	4
R 100 Ex	60	99	115	90	10	4	4
R 125 Ex	80	125	142	90	10	8	8
R 127 Ex	80	127	142	90	10	8	8
R 150 Ex	90	150	165	95	13	8	8
R 200 Ex	120	200	213	95	13	8	8

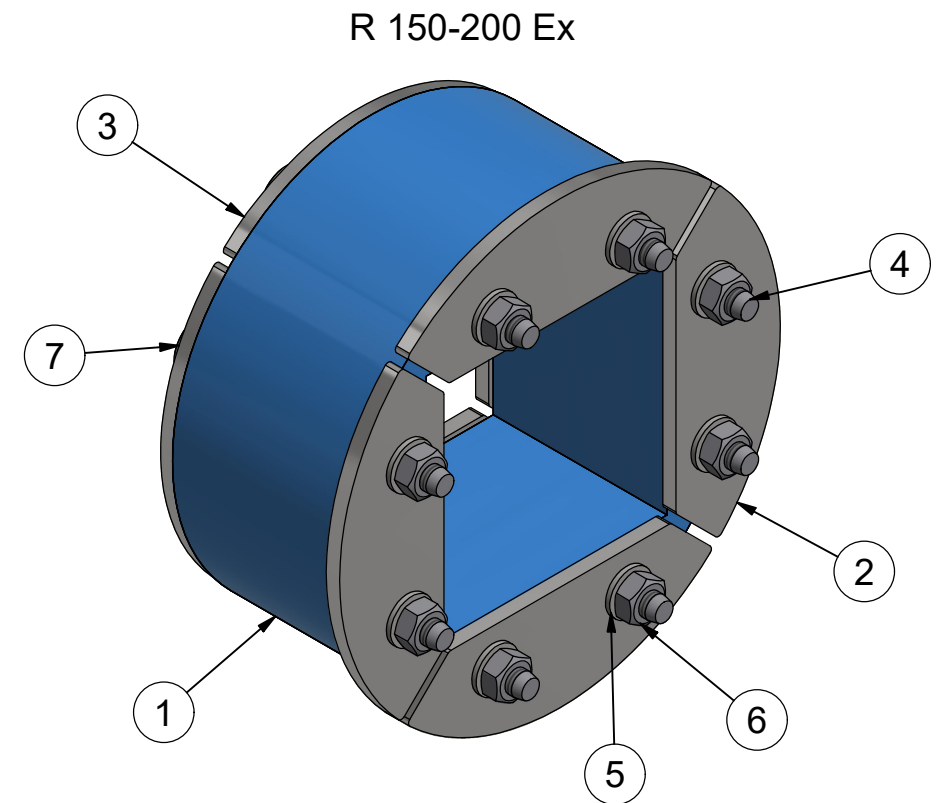
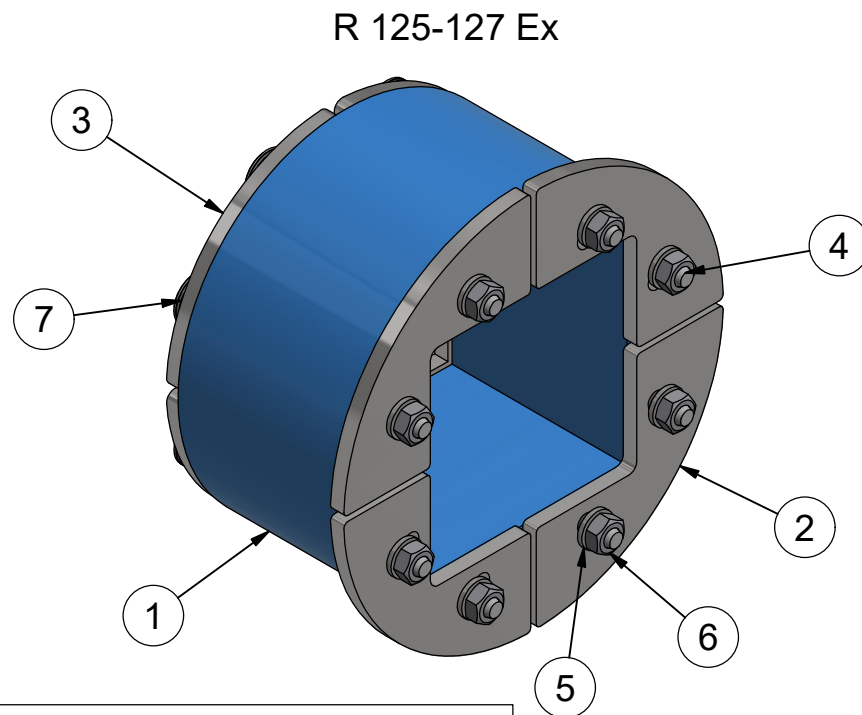
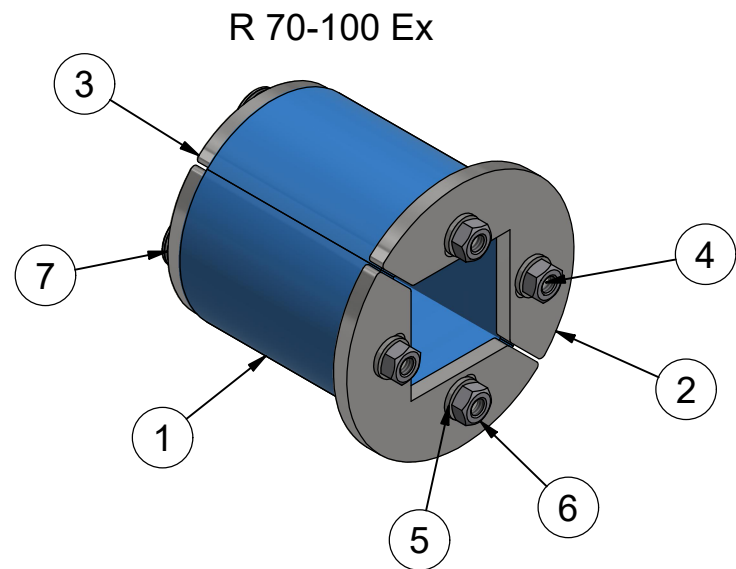

7	G	GASKET					
6	N	NUT				ISO 4032 A4	
5	W	WASHER				ISO 7089 A4	
4	S	SCREW				DIN 603 A4	
3	-	REAR FITTING				STAINLESS STEEL	
2	-	FRONT FITTING				STAINLESS STEEL	
1	-	RUBBER FRAME				ROXYLON	
ITEM	QTY	Designation	Specification				Weight
General tolerances used for manufacturing shown in document DOC-002180			Designed by/date se-marprz 2009-03-10	Latest save date 2024-07-05	Format A3	Scale	Sheet no 1 / 1
 www.roxtec.com			Title R 70-200 Ex ASSEMBLY				Projection method 
Restricted due to			Information drawing		Drawing number		Rev
					S1016600		A

A	LAYOUT CHANGED	2024-07-01	se-marfre
Rev	Type of revision	Date	Sign