

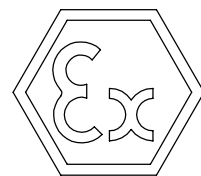

TYPE	Di	Do	L	MATERIAL
SLR-70	71,5	83	55	St.52-3N
SLR-75	76,5	89	55	St.35
SLR-100	101	114	55	St.52-3N
SLR-125	126	140	55	St.52-3N
SLR-127	128	140	55	St.52-3N
SLR-150	151	164	55	St.52-3N
SLR-200	201	214	55	St.52-3N

MATERIAL AND SURFACE TREATMENT				
SHARP EDGES BROKEN				
-	ST 35	S235G2T	-	-
-	ST 52-3N	S355J2G3	-	-
2	PRIMED, BLACK ACC. TO S1005244			
F	SS 4212	EN AW-6082	3.2315	AA 6082
E	SS 2353	X2CrNiMo18-14-3	1.4435	AISI 316L

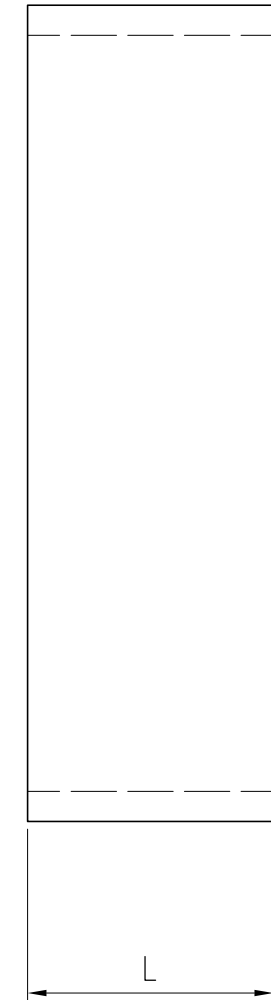
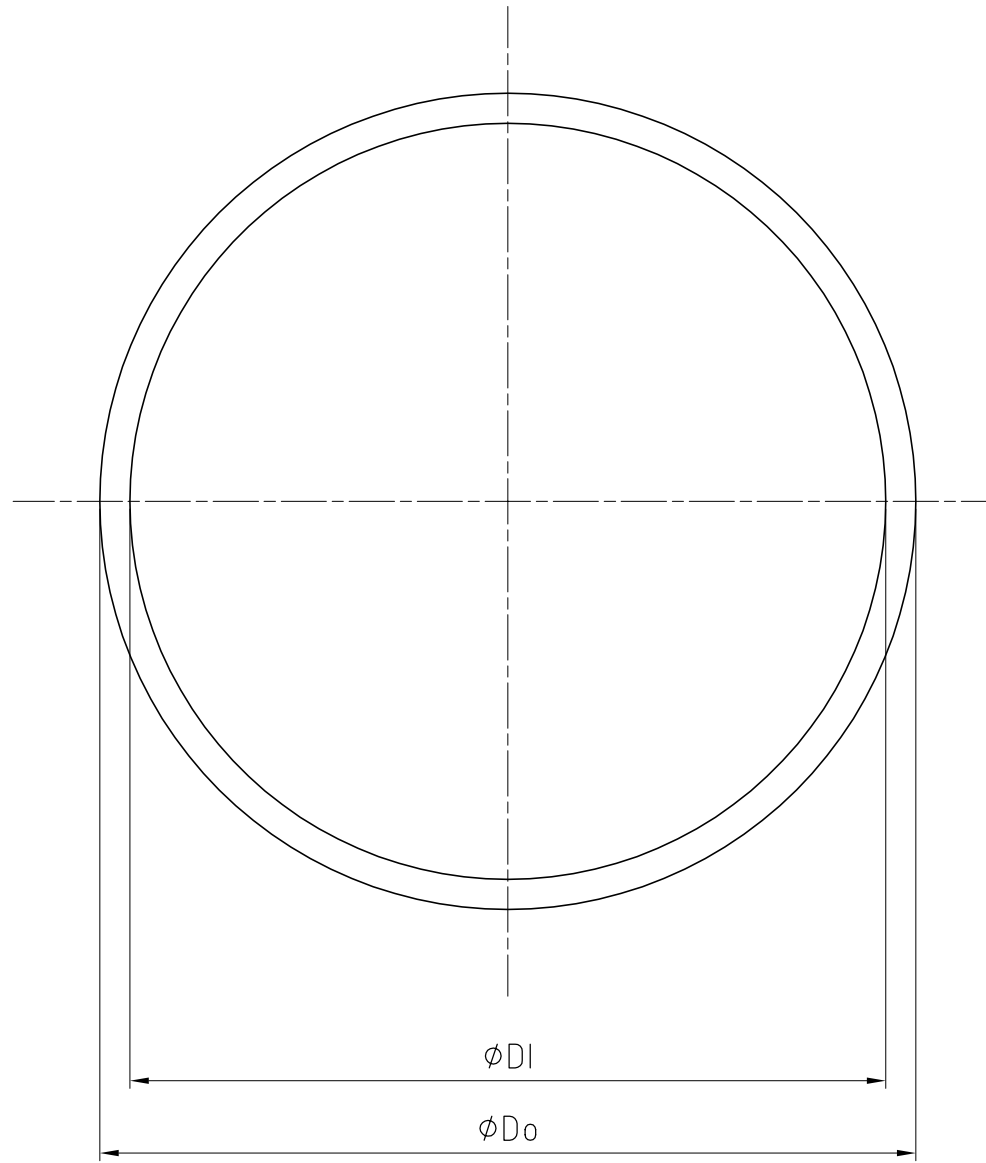

We reserve all rights in this document and in the information contained therein. Reproduction, use or disclosure to third parties without express authority is strictly forbidden. ©ROXTEC INTERNATIONAL AB

Rev	Type of revision	Date	Sign
-	-		

Item	Qty	Designation	Specification				Net Weight
ROXTEC INTERNATIONAL AB BOX 540 S-371 23 Karlskrona TEL: +46 455 366700 FAX: +46 455 82012		AN KARLSSON Checked by JE BOHLIN Approved by JE BOHLIN	Date 2005-11-14	General tolerance ISO 2768-1 m	Welded details SS-EN 25 817 SS-EN 30 042 -	General surface roughness, Ra -	Tot Weight -
			Format A3	Scale 1:2	Title SLR EX SLR 70 - SLR 200	Projection method 	Rev -
		Restricted due to INFORMATION DRAWING	Drawing number S1008611				