

所有权利保留。未经授权严禁复制或向第三方泄露。

All rights reserved. Unauthorized reproduction, use or disclosure to third parties is strictly forbidden.

Rev 2.0

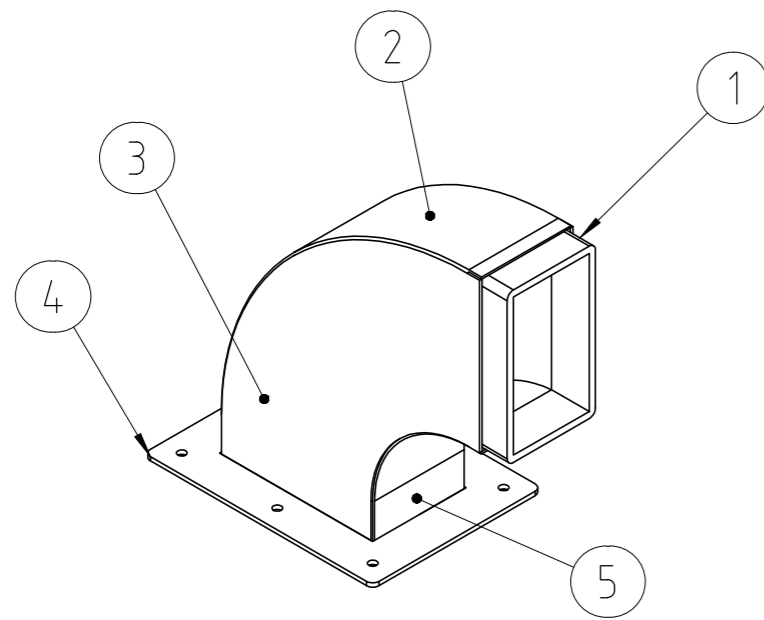

SCALE 1:2

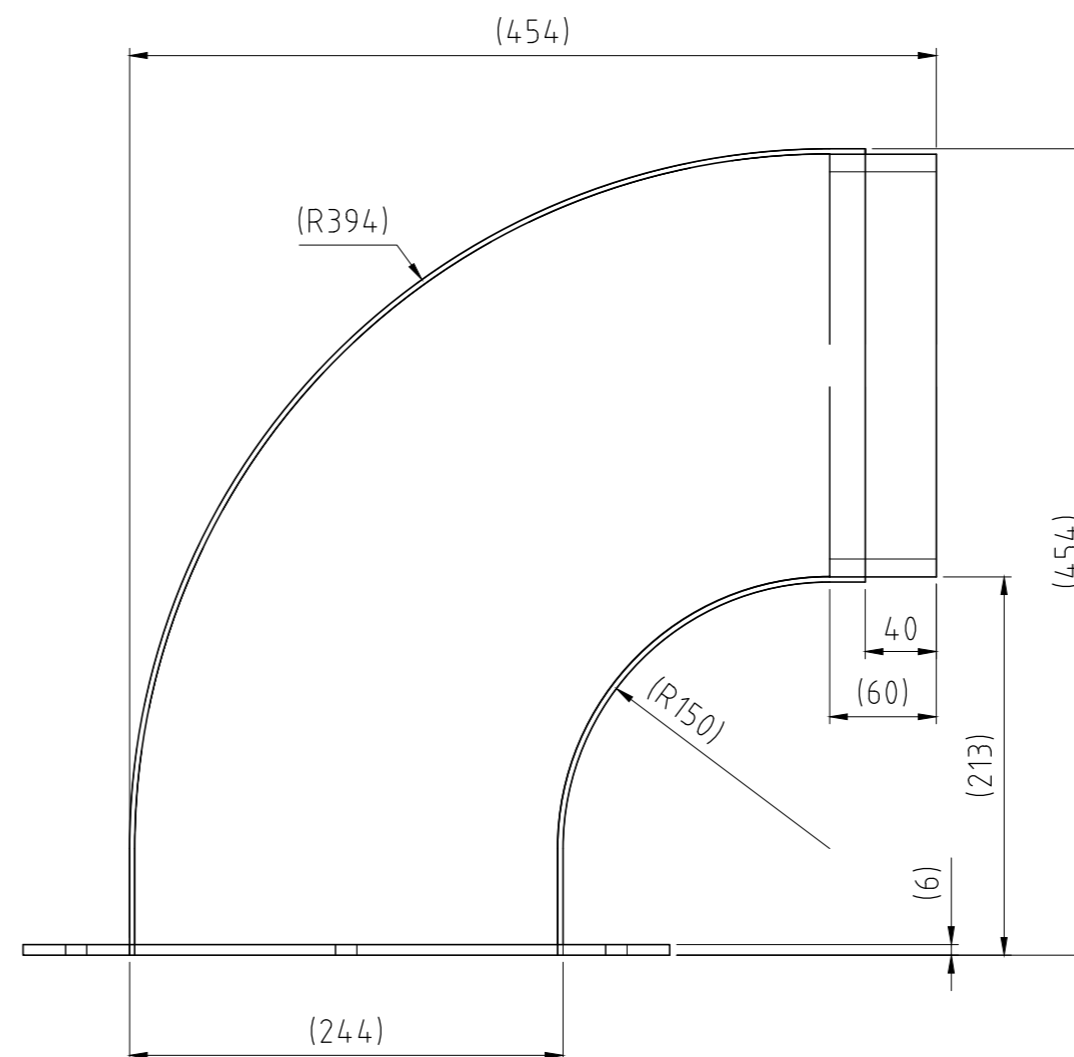
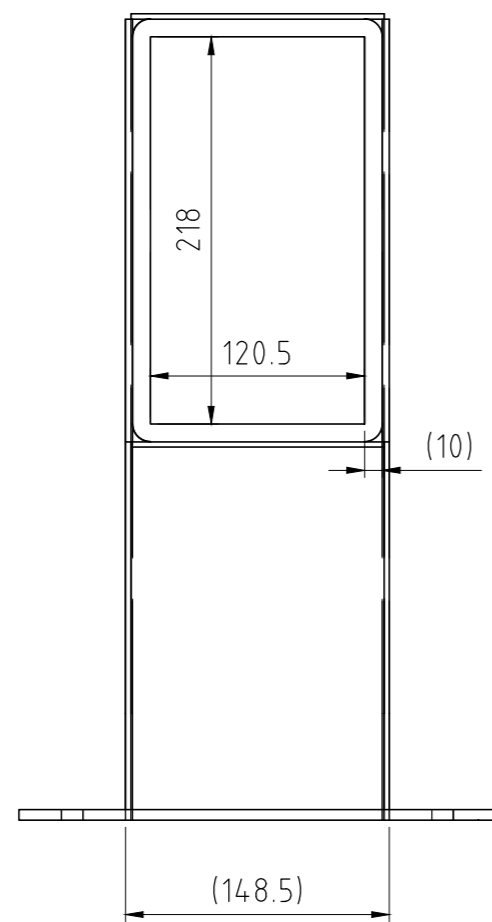
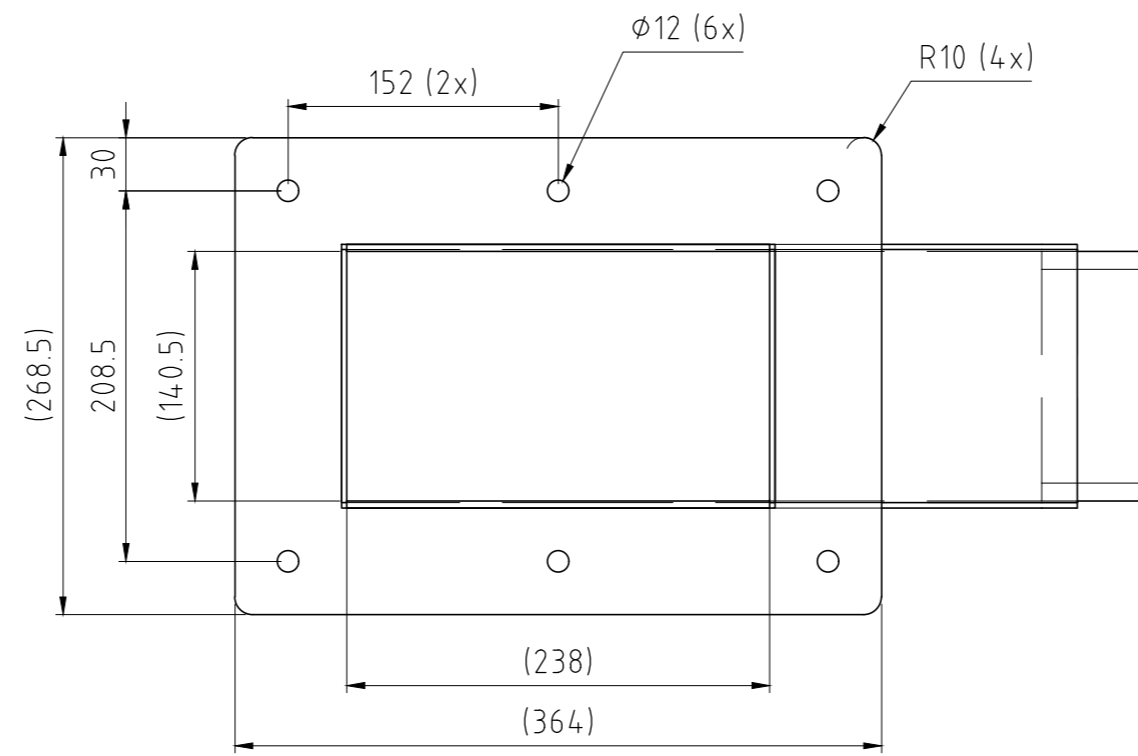

WEIGHT APPROX.:  
Steel: 17,5 Kg / Alu: 6 Kg

Item	Qty	Designation	Specification	NetWeight
5	1	INSIDE PLATE	T=3	
4	1	FLANGE	T=6	
3	2	SIDE PLATE	T=4	
2	1	OUTSIDE PLATE	T=3	
1	1	S 6x1	T=10	

General tolerances used for manufacturing shown in document 00C-00780		Designed by	Created Date	Latest save date	Format	Scale	Sheet no	TotalWeight
		se-pertor	2002-05-06	2019-05-07	A2	1:4		-
www.roxtec.com		Title		Projection method		Rev		
		SWAN NECK		S 6x1		Information drawing		
		Restricted due to		Drawing number		Rev		
				S1003624		B		

Information drawings show general design and nominal dimensions if not else stated

Rev	Type of revision	Date	Sign
B	UPDATED TITLE BORDER	2019-05-03	se-linado