

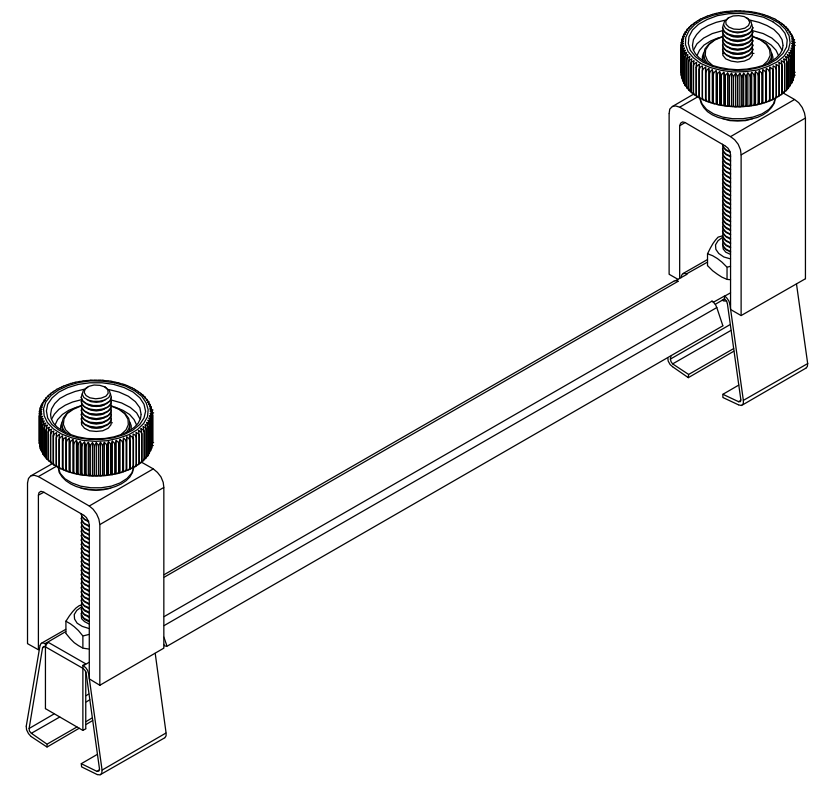

烙克赛克保留所有权利。未经授权严禁复制，
使用以及向第三方泄漏。

All rights reserved. Unauthorized reproduction, use
or disclosure to third parties is strictly forbidden.

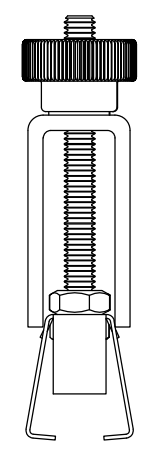
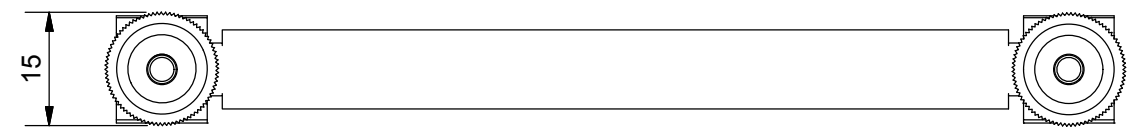
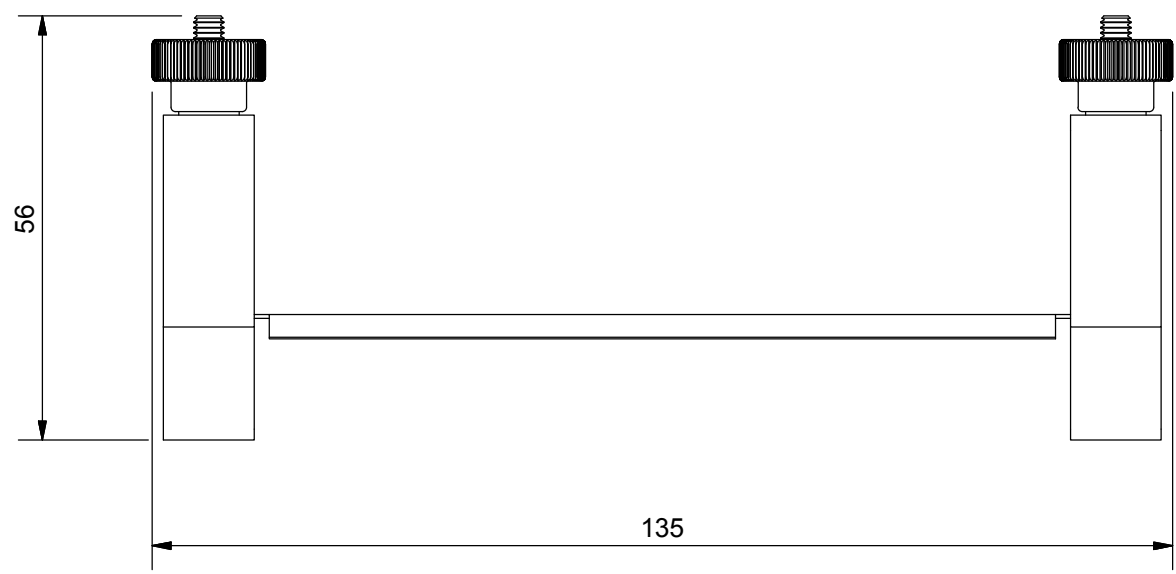

A		2017-09-21	se-jenboh
Rev	Type of revision	Date	Sign

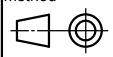
General tolerance: ISO 2768-1/2-m/K EN ISO 13920-BF	Welded details: EN ISO 5817-B EN ISO 10042-B	General surface roughness: Ra 12.5	Designed by/date se-pertor 2002-04-11	Latest save date 2017-10-06	Format A3	Scale	Sheet no 1 / 1	TotWeight N/A
 Roxtec www.roxtec.com		Title ROXTEC TOOLS STAYPLATE CLAMP			Projection method 		Rev A	
		Restricted due to Information drawing			Drawing number S1003526			