

Installation instructions Roxtec C RS SLO seal

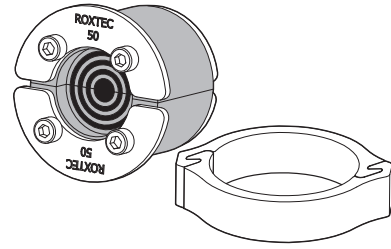

Components

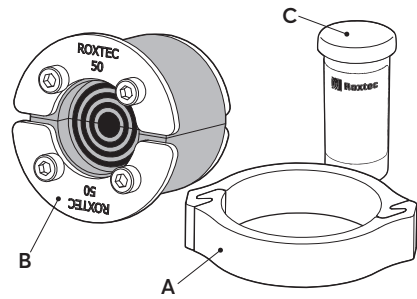

A: Roxtec C SLO sleeve.
B: Roxtec C RS seal.
C: Roxtec Lubricant Blue.

Additional information

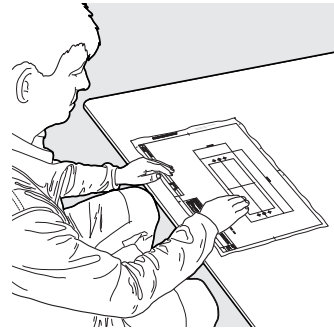

Visit roxtec.com for additional information such as drawings, aperture, videos, ratings and certificates.

Technical data

The amount of torque needed to compress the seal depends on several things, e.g cable or pipe size, amount of used lubricant, aperture size or material in the cable sheath, etc. Thickness of the structure must be between 4 mm and 10 mm.

Name	Aperture dimension Ø (mm)	For cable/pipe Ø (mm)	Torque (Nm)	Tool size (mm)
C RS SLO 43	44 – 46	4 – 23	~ 4	4
C RS SLO 50	51 – 53	8 – 30	~ 4	4
C RS SLO 68	69 – 71	26 – 48	~ 4	4
C RS SLO 75	76 – 78	24 – 54	~ 4	4

Tools

- Allen key (not included)

Installation

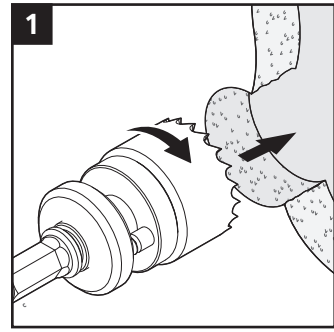

1 Make or verify an aperture.

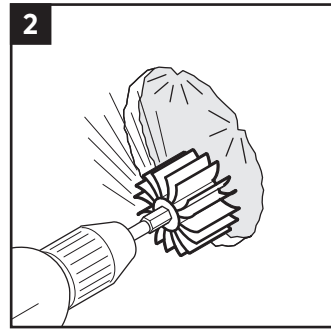

2 Remove all sharp edges to avoid damage to the rubber of the seal.

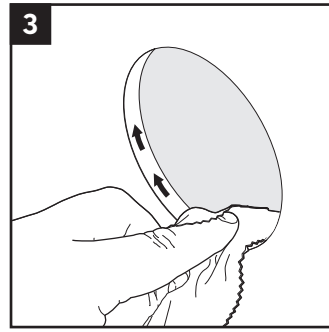

3 Clean the aperture.

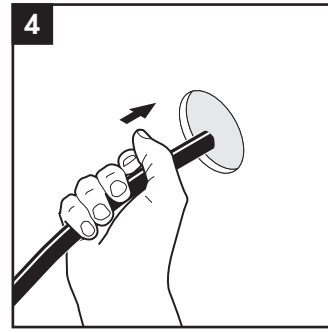

4 Route the cable through the aperture.

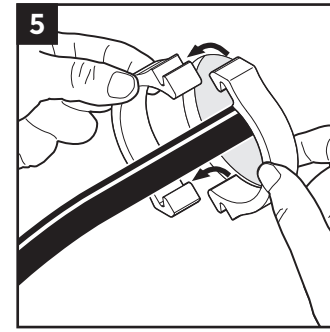

5 Assemble the sleeve around the cable.

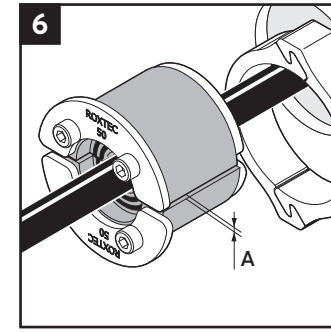

6 Achieve a 0-1.0 mm gap (A) between the two halves when held against the cable/pipe.

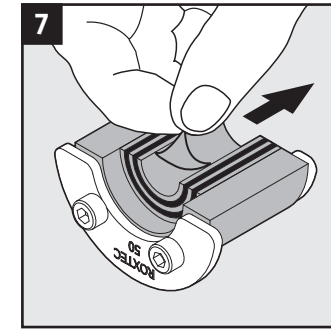

7 Adapt the seal by peeling off layers.

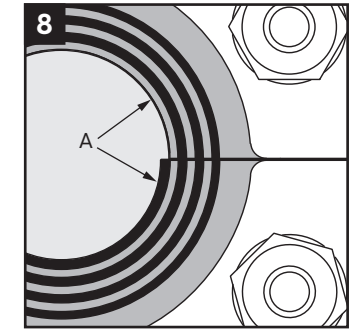

8 The number of layers may not differ (A) by more than one between the corresponding seal halves.

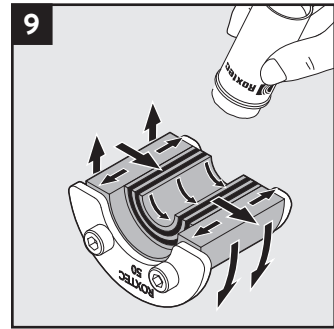

9 Lubricate the inside and the outside sealing surfaces with Roxtec Lubricant Blue.

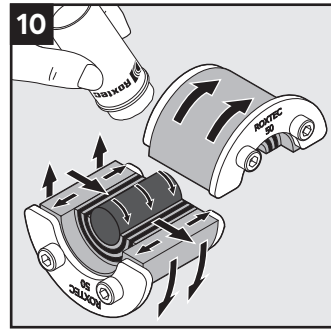

10 Lubricate the sealing surfaces of any spare seal. Do not remove the core.

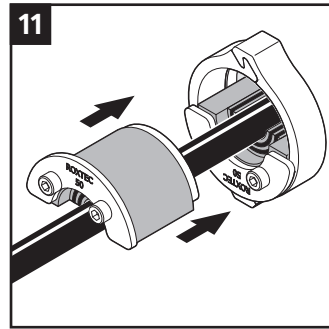

11 Insert the halves into the sleeve.

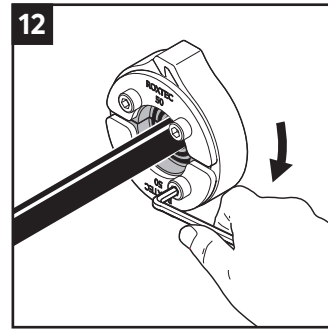

12 Tighten the bolts crosswise in small steps.

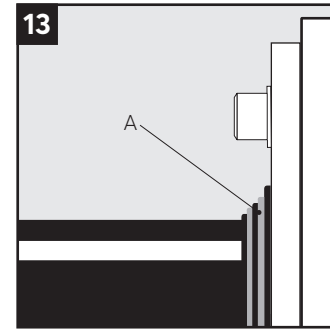

13 Bulging rubber (A) indicates a tight seal.

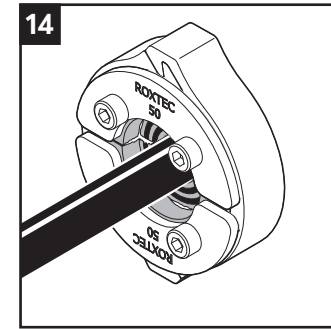

14 Visible protruding lubricant indicates a tight seal.

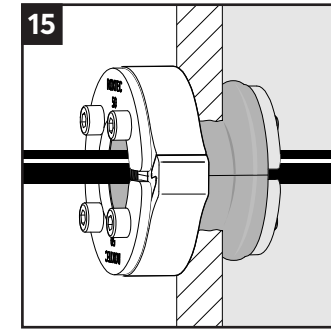

15 The rubber of the seal shall bulge on the back side.

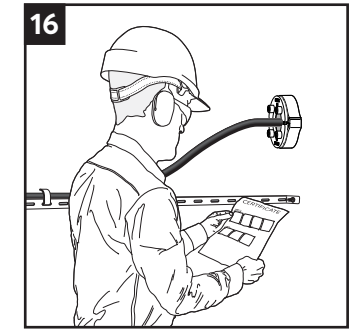

16 Check additional documentation, if applicable.

After installation inspection

- Are the screws tightened evenly?
- Are the layers peeled correctly?
- Is lubricant protruding?
- Is the rubber bulging?

Note

- For optimum reliability, wait 24 hours or longer after installation before exposing the cables/pipes to strain or pressure.
- Cables/pipes shall be parallel to the sleeve/aperture.
- Cable/pipe with a considerable weight needs to be supported to prevent damage or subsidence to the seal.
- Approvals or certificates may include amendments or limitations related to this application.
- A seal with core is spare capacity.
- The latest version of this and related documents are found at roxtec.com.

Disclaimer

"The Roxtec cable and pipe entry sealing system ('the Roxtec system') is a modular-based system of sealing products consisting of different components. Each and every one of the components is necessary for the best performance of the Roxtec system. The Roxtec system has been certified to resist a number of different hazards. Any such certification, and the ability of the Roxtec system to resist such hazards, is dependent on all components that are installed as a part of the Roxtec system. Thus, the certification is not valid and does not apply unless all components installed as part of the Roxtec system are manufactured by or under license from Roxtec (authorized manufacturer). Roxtec gives no performance guarantee with respect to the Roxtec system, unless (I) all components installed as part of the Roxtec system are manufactured by an authorized manufacturer and (II) the purchaser is in compliance with (a), and (b), below.

(a) During storage, the Roxtec system or part thereof, shall be kept indoors in its original packaging at room temperature.

(b) Installation shall be carried out in accordance with Roxtec installation instructions in effect from time to time.

The product information provided by Roxtec does not release the purchaser of the Roxtec system, or part thereof, from the obligation to independently

determine the suitability of the products for the intended process, installation and/or use.

Roxtec gives no guarantee for the Roxtec system or any part thereof and assumes no liability for any loss or damage whatsoever, whether direct, indirect, consequential, loss of profit or otherwise, occurred or caused by the Roxtec systems or installations containing components not manufactured by an authorized manufacturer and/or occurred or caused by the use of the Roxtec system in a manner or for an application other than for which the Roxtec system was designed or intended.

Roxtec expressly excludes any implied warranties of merchantability and fitness for a particular purpose and all other express or implied representations and warranties provided by statute or common law. User determines suitability of the Roxtec system for intended use and assumes all risk and liability in connection therewith. In no event shall Roxtec be liable for indirect, consequential, punitive, special, exemplary or incidental damages or losses.

The Roxtec products are offered and sold in accordance with the conditions of the Roxtec General Terms of Sales. The latest version of the Roxtec General Terms of Sales can be found and downloaded from roxtec.com/general-terms-of-sales.



Roxtec International AB
 Box 540, 371 23 Karlskrona, SWEDEN
 +46 455 36 67 00, info@roxtec.com
www.roxtec.com