

Installation instructions

Roxtec HD 16 transit with CM BG™ B modules

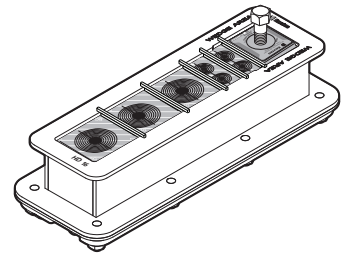

Safety information

Roxtec recommends that all installations are performed without facility operation. Follow national regulations and installation codes. Any action affecting the routed service should be performed according to manufacturer recommendations.

Components

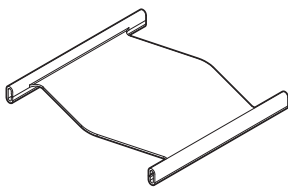

Stayplate

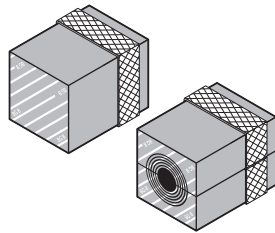

Roxtec CM BG B modules

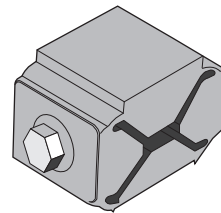

Roxtec compression unit C
Wedge HD AISI 316



Roxtec Lubricant

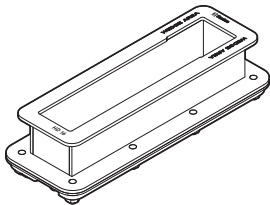

Roxtec HD 16 frame including
gasket

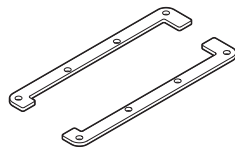

Roxtec counterframe

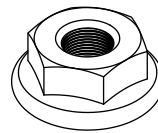

Nuts



Fasteners for protective bonding
conductor

Additional information

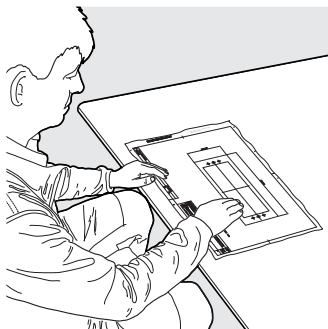

Additional information is available, such as drawings, apertures, videos, ratings and certificates.



Scan QR code or visit roxtec.com for additional information.

Technical data

The diameter range of the modules indicates the smallest diameter of the exposed cable armor to the largest diameter of the cable jacket. Modules with core are spare capacity.

Name	External dimensions WxHxD (mm)	For cable/pipe Ø (mm)	Braid cross-section/cable (mm ²)	Approximately equivalent AWG
CM 20 BG B	20 x 20 x 40	4 – 14.5	8	8
CM 20w40 BG B	40 x 20 x 40	3.5 – 16.5	4	11
CM 30w40 BG B	40 x 30 x 40	10 – 25	13	6
CM 40 10–32 BG B	40 x 40 x 40	9.5 – 32.5	21	4
CM 40 BG B	40 x 40 x 40	21.5 – 34.5	21	4
CM 10w40/0 BG B	40 x 10 x 40	0	–	–
CM 20/0 BG B	20 x 20 x 40	0	–	–
CM 40/0 BG B	40 x 40 x 40	0	–	–

Tools

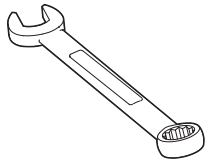

10 mm and 13 mm spanner (not included)

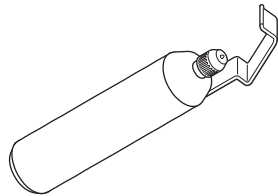

Cable stripper tool. Recommended by the cable manufacturer (not included)

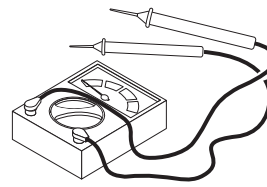

Continuity tester (not included)



Screwdriver (not included)

Packing space

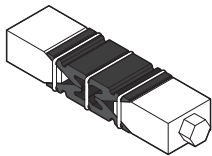

Roxtec pre-compression wedge (not included)

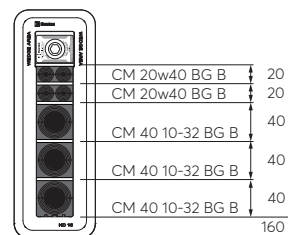

The sum of module heights must be 160 mm.

Principle of cable placement in module

- A. Environmental side
- B. Termination/interior side
- C. Removable layers
- D. Cable armor
- E. Bonding/grounding braid
- F. Cable jacket

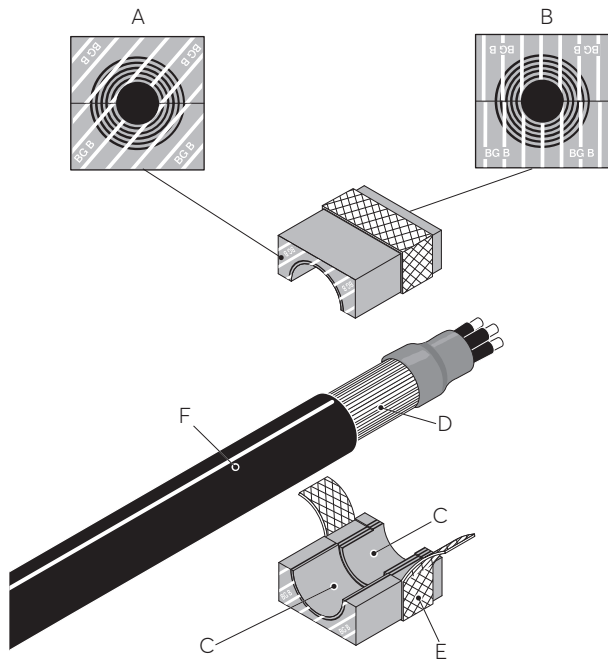

Cable with terminated armor.

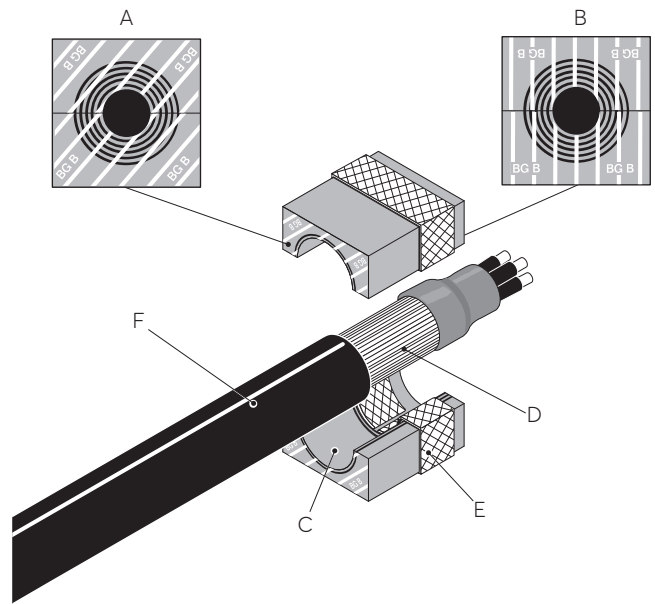

The braid is folded in.

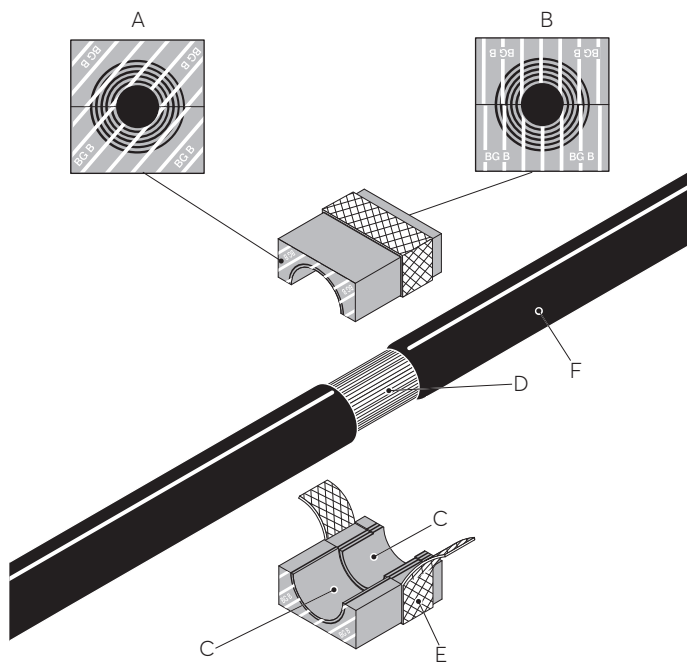

Cable with pass-through armor.

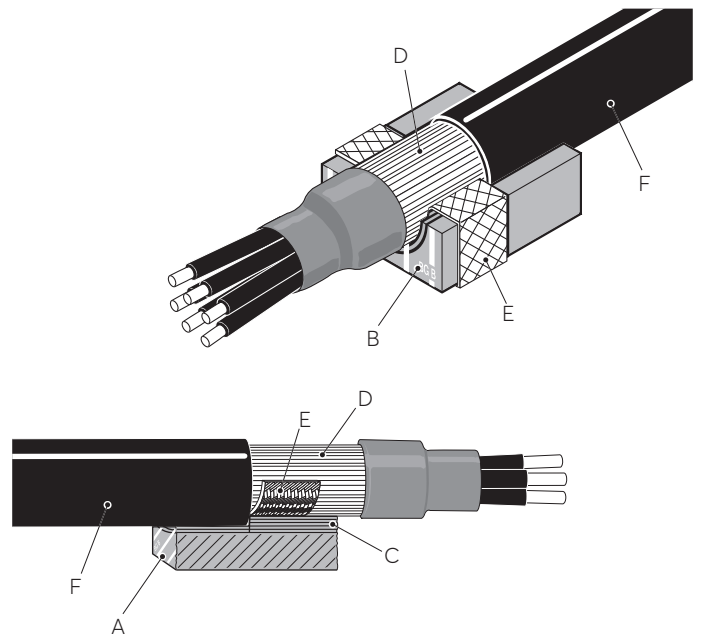

Cable placement in the module half. The cable jacket edge shall be in contact with the edge of the removable layers.

Installation

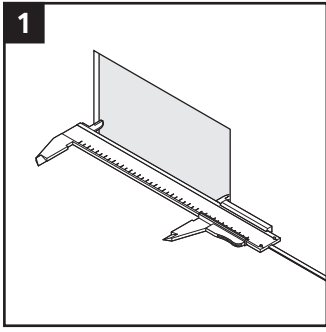

1 Make or verify an aperture.

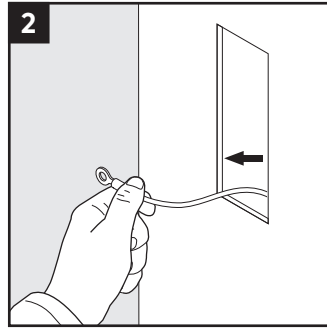

2 Route the protective bonding conductor through the aperture.

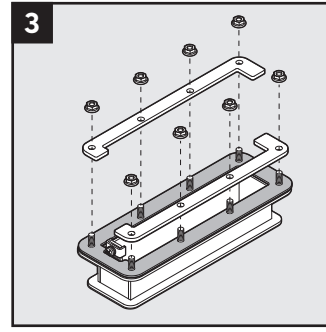

3 Remove all nuts and the two counterframes.

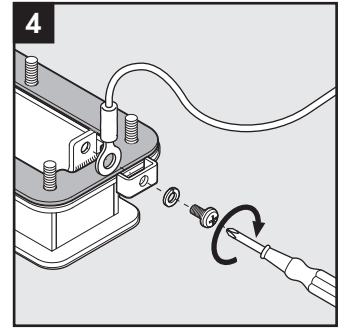

4 Attach the protective bonding conductor to the earthing terminal.

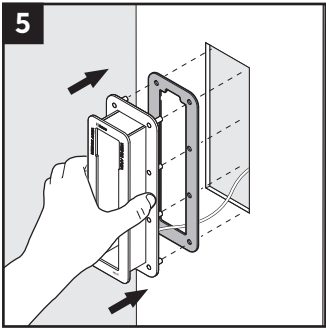

5 Insert the frame from the outside of the cabinet. Ensure that the gasket is placed between the frame and the cabinet.

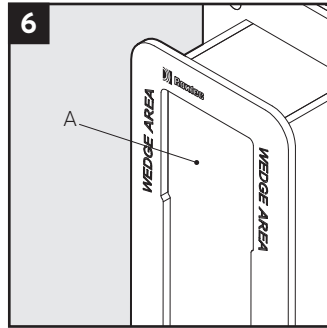

6 Observe the intended wedge areas (A) without stopping edges.

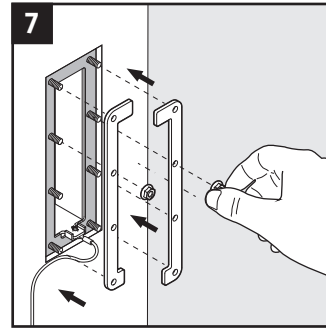

7 Attach the two counterframes from the inside of the cabinet.

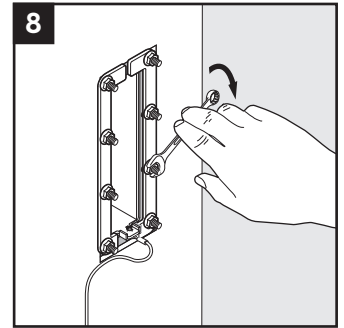

8 Tighten the nuts crosswise in small steps. Recommended torque 4 Nm. Do not overtighten the nuts.

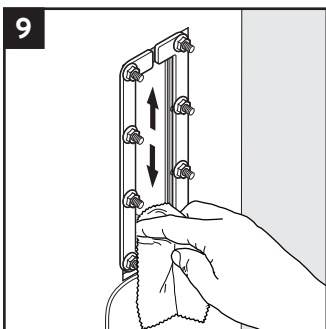

9 Clean the frame.

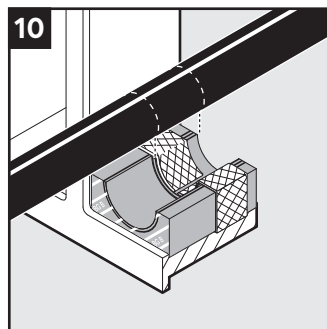

10 Mark where the outer jacket is to be removed to fit the module braid.

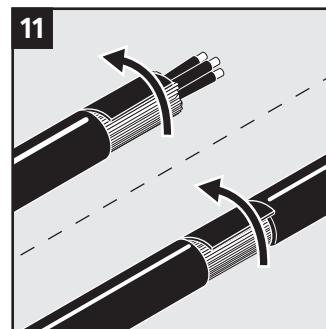

11 Remove the outer jacket and any plastic foil. The cable armor shall be clean and conductive.

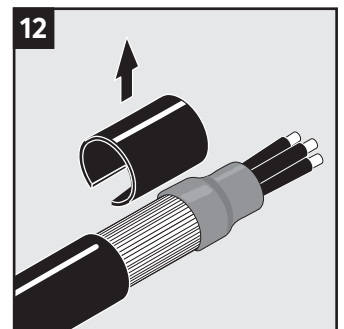

12 Secure the end of the cable armor. Suggestions for cable preparations are available on roxtec.com.

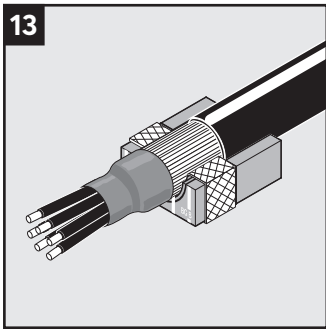

13 Correct placement of a cable in a CM BG B module. The cable armor shall be visible outside the module.

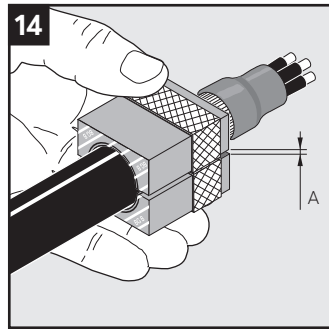

14 Achieve a gap of 0.1-1.0 mm (A) between the module halves by peeling off layers.

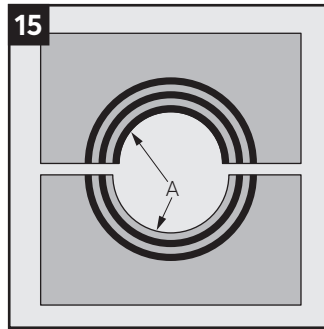

15 The number of layers may not differ (A) by more than one between the corresponding module halves.

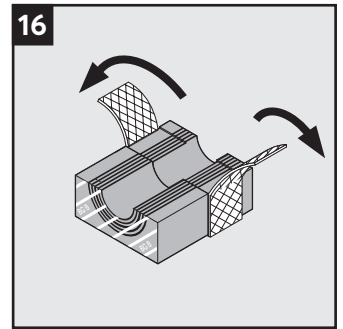

16 Remove the core and fold out the braid. Also see section for modules with multiple openings.

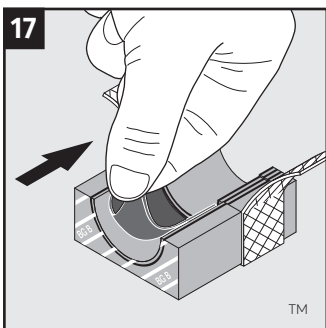

17 Adapt the layers that are in contact with the cable jacket.

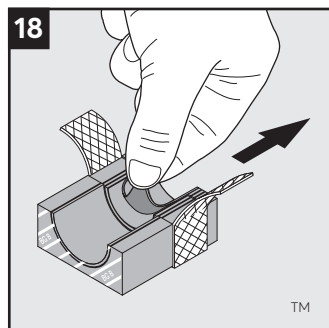

18 Adapt the layers that are in contact with the cable armor.

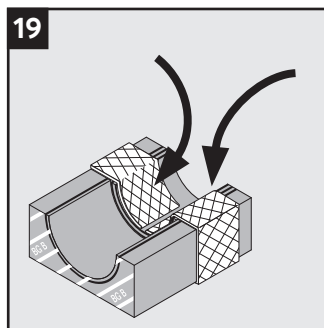

19 Fold the braid tightly inside the module half. Check the gap.

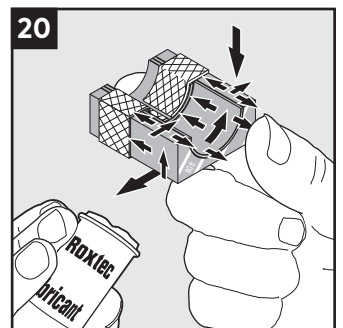

20 Lubricate the sealing surfaces of all modules. Avoid excess lubricant on the braid.

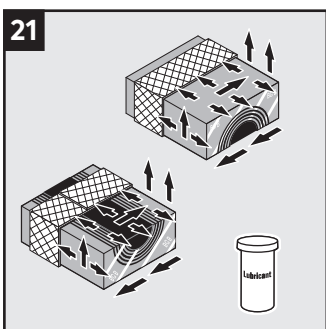

21 Lubricate the sealing surfaces of the spare modules. Do not remove the core.

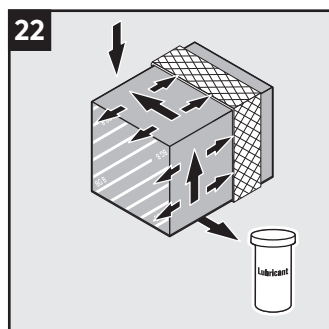

22 Lubricate the sealing surfaces of the solid modules.

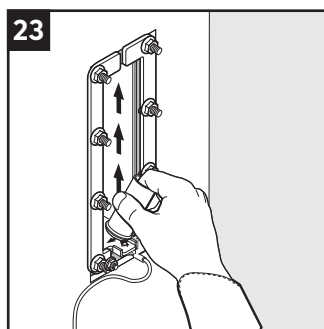

23 Lubricate the sealing surfaces of the frame, especially in the corners. Lubricate the area that will be in contact with the braid sparsely.

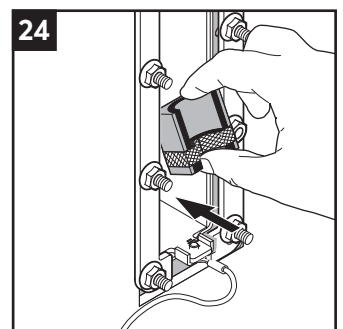

24 Insert the modules at an angle from the backside of the transit according to your packing plan.

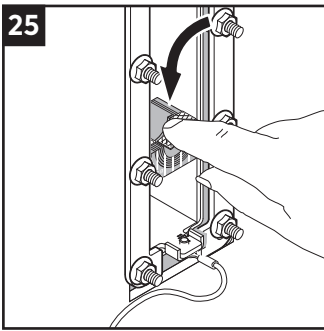

25 Turn the modules in line with the frame.

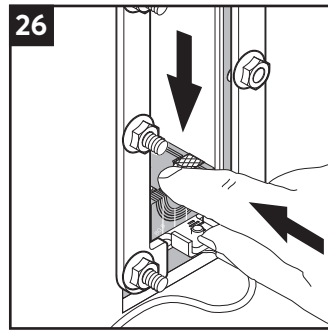

26 Push the modules in place. Ensure that the module rests against the stopping edge at the front.

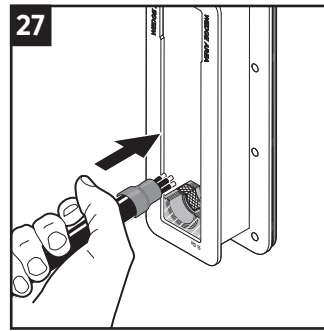

27 Insert the cables through the frame.

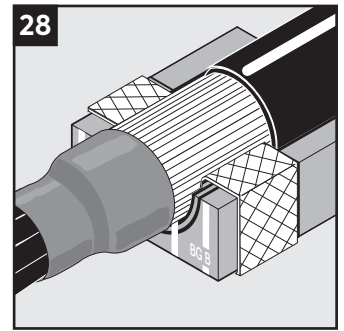

28 When placing cables in modules, the cable armor shall be visible outside the module at the termination side.

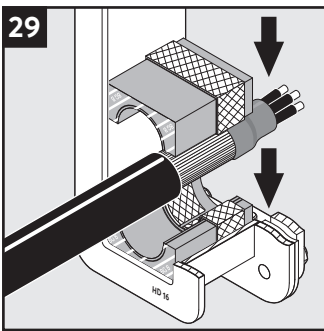

29 Place cables, according to your packing plan, in the module halves. Place corresponding module halves on top.

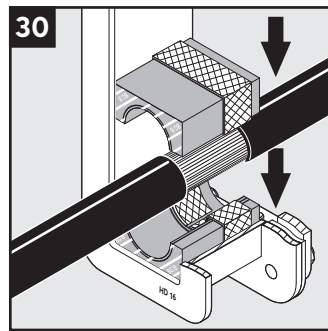

30 For pass-through cables, cable armor shall be visible on the termination side.

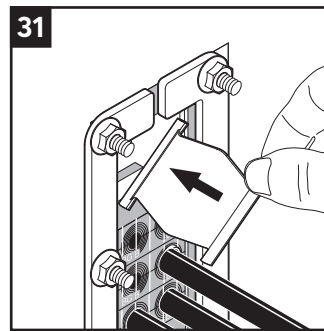

31 Before inserting the final module, insert a stayplate.



32 Lift up the stayplate and insert the last module underneath it.

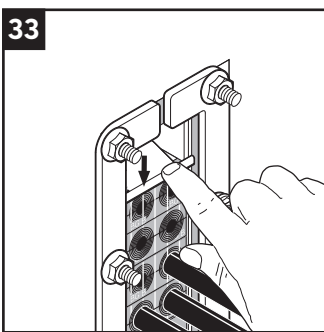

33 Drop the stayplate on top of the last module. Make sure the combinations of modules equal the 160 mm packing space.

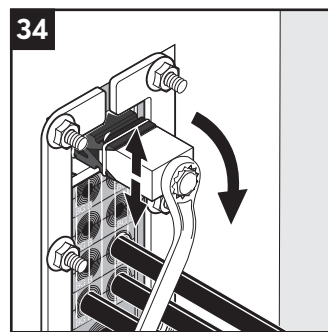

34 Use a Roxtec pre-compression tool to make space for the compression unit if required.

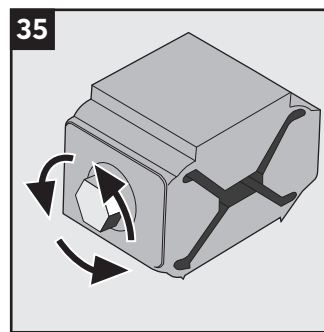

35 Turn the screw of the compression unit counter-clockwise to full stop.

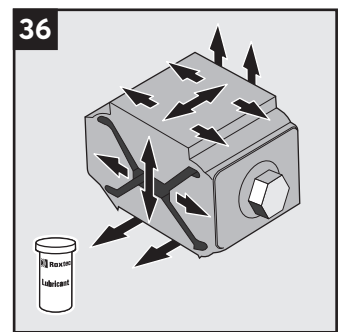

36 Lubricate the sealing surfaces of the compression unit.

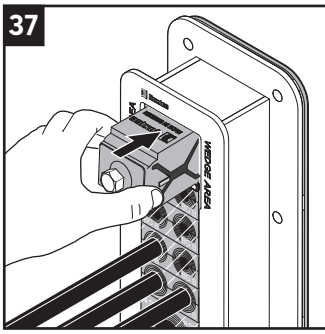

Insert the compression unit until stop.

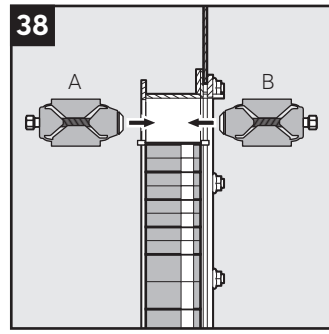

The compression unit can be placed with the screwhead facing the inside (B) or the outside (A) of the frame.

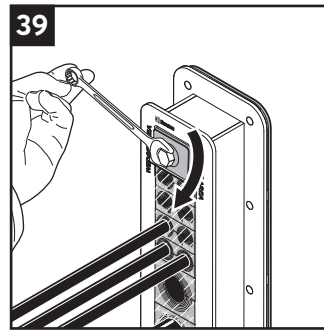

Tighten the screw of the compression unit until full stop, approx. 20 Nm.

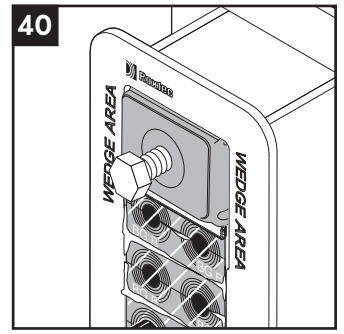

Visible excess lubricant is a sign of good compression. Make sure that all modules are placed correctly and fully inserted after compression.

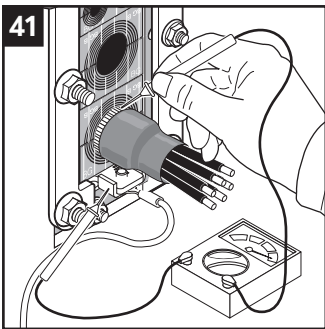

Verify earth continuity from each cable armor to the earthing terminal using a suitable instrument.

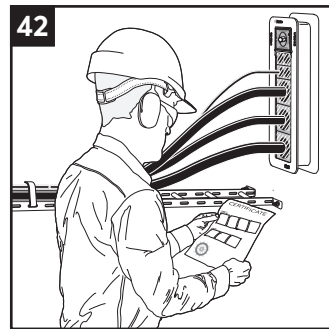

Check additional documentation, if applicable.

After installation inspection

- Are the wedge screws tightened to full mechanical stop?
- Is there visible protruding lubricant?
- Is the combined height of modules correct according to the frame packing height?
- Are all modules placed correctly and fully inserted after compression?

Modules with multiple openings

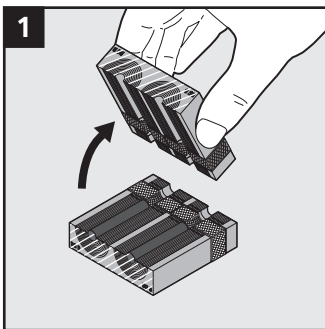

For modules with multiple openings, take extra care when peeling layers.

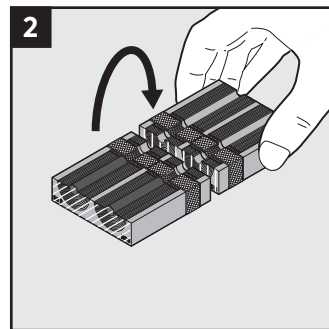

Folding the halves like this will line up corresponding openings.

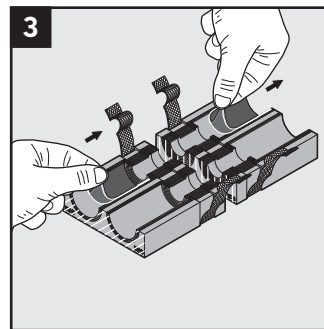

Adapt one opening at a time by removing layers.

Disassembly and reinstallation

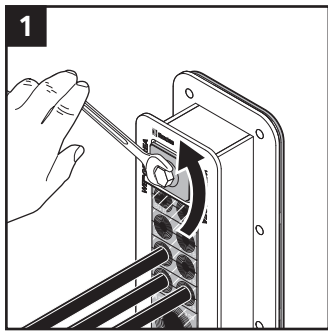

1 Untighten the screw of the compression unit.

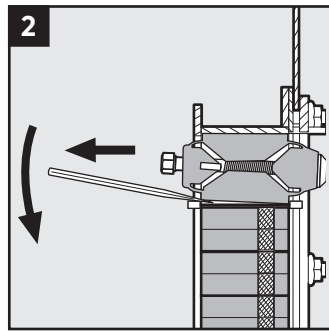

2 Insert a flat tool between the compression unit and the stayplate to simplify removal of the compression unit.

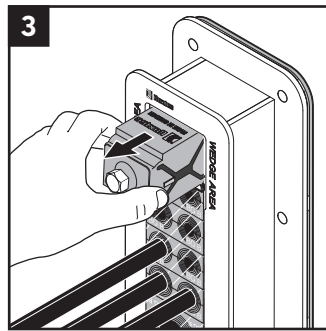

3 Remove the compression unit.

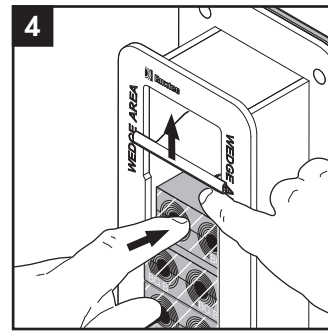

4 Lift up the stayplate and push out the first module from the front side.

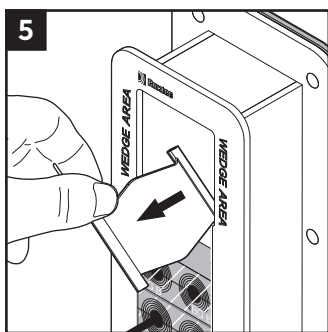

5 Remove the stayplate.

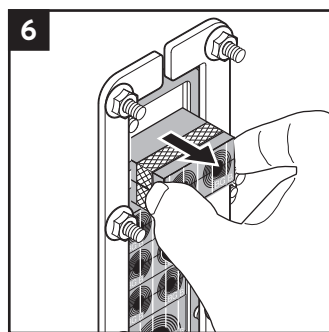

6 Continue to remove the modules by pulling them out from the backside of the frame. Do not damage the braids.

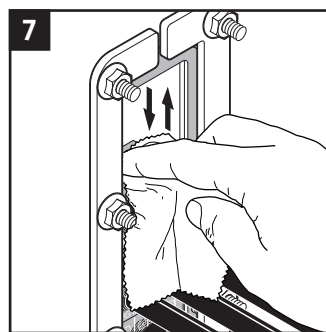

7 The inside surfaces of the exposed packing space shall be clean and conductive.

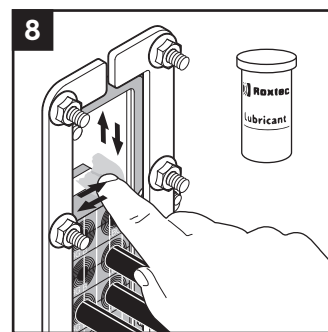

8 Lubricate the inside surfaces, especially in the corners. Continue the reinstallation.

Note

- Integrated environmental sealing system for bonding and grounding applications. For use with armored cables.
- For non-armored cables, the cable jacket is not removed. No bonding/grounding functionality will be achieved for the cable.
- The final complete bonding/grounding installation has to comply with applicable codes and regulations.
- To be used with Roxtec CM BG B modules.
- An incorrectly adapted module shall be replaced (layers shall not be reused).
- For optimum reliability, wait 24 hours or longer after installation before exposing the cables or pipes to strain or pressure.
- Cables shall go straight through the frame.
- Cable/pipe with a considerable weight needs to be supported.
- Partially installed openings shall be compressed if left unattended.
- Approvals or certificates may include amendments or limitations related to this application.
- The latest version of this and related documents are found at roxtec.com.

Disclaimer

The Roxtec cable and pipe entry sealing system ('the Roxtec system') is a modular-based system of sealing products consisting of different components. Each and every one of the components is necessary for the best performance of the Roxtec system. The Roxtec system has been certified to resist a number of different hazards. Any such certification, and the ability of the Roxtec system to resist such hazards, is dependent on all components that are installed as a part of the Roxtec system. Thus, the certification is not valid and does not apply unless all components installed as part of the Roxtec system are manufactured by or under license from Roxtec ('authorized manufacturer'). Roxtec gives no performance guarantee with respect to the Roxtec system, unless (I) all components installed as part of the Roxtec system are manufactured by an authorized manufacturer and (II) the purchaser is in compliance with (a), and (b), below.

(a) During storage, the Roxtec system or part thereof, shall be kept indoors in its original packaging at room temperature.

(b) Installation shall be carried out in accordance with Roxtec installation instructions in effect from time to time.

The product information provided by Roxtec does not release the purchaser of the Roxtec system, or part thereof, from the obligation to independently

determine the suitability of the products for the intended process, installation and/or use.

Roxtec gives no guarantee for the Roxtec system or any part thereof and assumes no liability for any loss or damage whatsoever, whether direct, indirect, consequential, loss of profit or otherwise, occurred or caused by the Roxtec systems or installations containing components not manufactured by an authorized manufacturer and/or occurred or caused by the use of the Roxtec system in a manner or for an application other than for which the Roxtec system was designed or intended.

Roxtec expressly excludes any implied warranties of merchantability and fitness for a particular purpose and all other express or implied representations and warranties provided by statute or common law. User determines suitability of the Roxtec system for intended use and assumes all risk and liability in connection therewith. In no event shall Roxtec be liable for indirect, consequential, punitive, special, exemplary or incidental damages or losses.

The Roxtec products are offered and sold in accordance with the conditions of the Roxtec General Terms of Sales. The latest version of the Roxtec General Terms of Sales can be found and downloaded from roxtec.com/general-terms-of-sales.



Roxtec International AB
Box 540, 371 23 Karlskrona, SWEDEN
+46 455 36 67 00, info@roxtec.com
www.roxtec.com