

Safety information

Roxtec recommends that all installations are performed without facility operation. Follow national regulations and installation codes. Any action affecting the routed service should be performed according to manufacturer recommendations.

General information

Installation and maintenance:
For European member countries of CENELEC, standards EN 60079-14 and EN 60079-17 shall be considered. For countries members of IECEx, standards IEC 60079-14 and IEC 60079-17 shall be considered. For other countries, applicable national regulation shall be considered.

The products fulfill the following standards:

EN IEC 60079-0:2018 (IEC 60079-0:2017)
EN 60079-7:2015/A1:2018 (IEC 60079-7:2015/A1:2018)
EN 60079-31:2014 (IEC 60079-31:2013)

CSA Std. C22.2 No. 18.3-12
CSA Std. C22.2 No. 94.2-15
CAN-CSA C22.2 No. 60079-0: 15
CAN-CSA C22.2 No. 60079-7: 16
CAN/CSA C22.2 No. 60079-31: 15

UL Standard 514B, 6th Ed.
UL Standard 50E, 2nd Ed
UL 60079-0 - 6th Ed.
UL 60079-7 - 5th Ed
UL 60079-31 - 2nd Ed

The cable transit devices are intended for use with permanently installed circular cross-section cables, with or without armoring or braided screen. Cable transit devices may also be used with permanently installed cables of types TECK90 according to standard C22.2 No. 131-07, ACWU according to standard UL4, MC according to standard UL1569 and ACIC cables according to CSA C22.1-06 CEC, UL 444, UL 1685, UL 13, UL2250, IEC 61158-2.



Installation instructions Roxtec HD 16 Ex with Roxtec CX modules

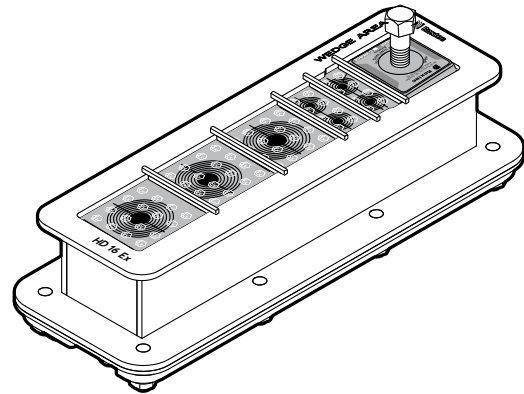

Components

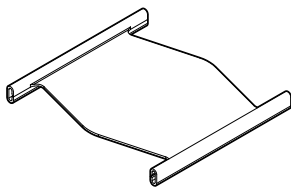

Stayplate Ex

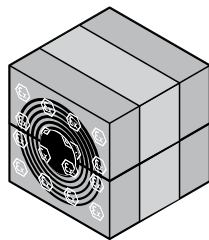

CX modules

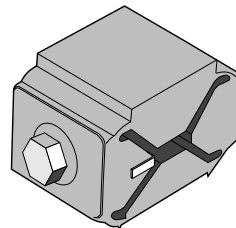

Compression unit
C Wedge 40 Ex AISI 316

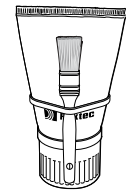

Assembly gel Ex

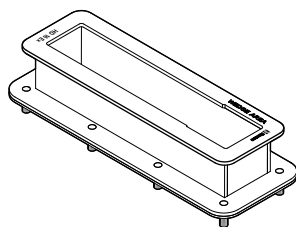

HD 16 Ex frame

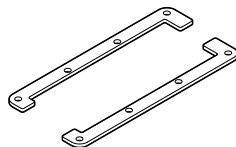

Counter frame

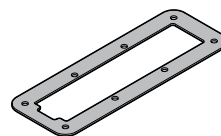

Gasket

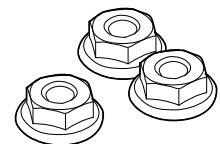

Fasteners

Aperture dimensions in cabinet

Measures in millimeters (mm).

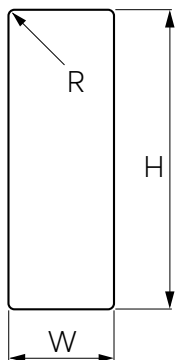

R: max 3.

H: 216 +1.0
-0.5

W: 64 +1.0
-0.5

Max wall/cabinet thickness: 4 mm.

Packing space

Example of packing plan

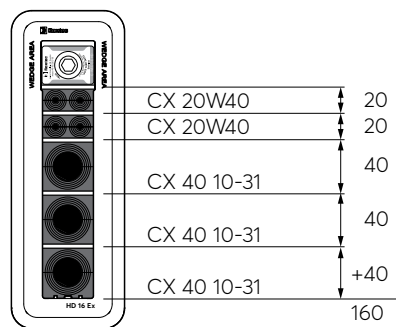

The sum of module heights must be 160 mm.

Adaptable CX modules

Measures in millimeters (mm)

Module	Number of cables	For cable diameter
CX 15w40	3	0+4.0-9.5
CX 20	1	0+4.0-13.5
CX 20w40	2	0+4.0-15.5
CX 30w40	1	0+10.0-24.0
CX 40	1	0+21.5-33.5
CX 40 10-31	1	0+9.5-31.0

Solid compensation modules CX

Module
CX 5w40/0
CX 10w40/0
CX 20/0
CX 40/0

Single diameter modules CX

Module
CX 20/14
CX 20/15
CX 20/16

Tools

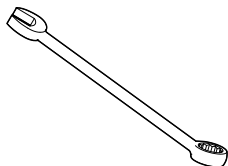

10 mm and 13 mm spanner
(not included)

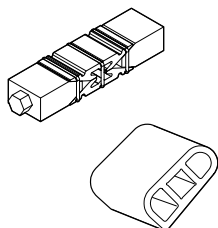

Roxtec
installation tools
(not included)

Installation of HD 16 Ex frame

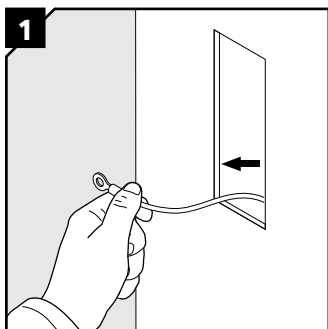

1 Route the protective bonding conductor through the aperture.

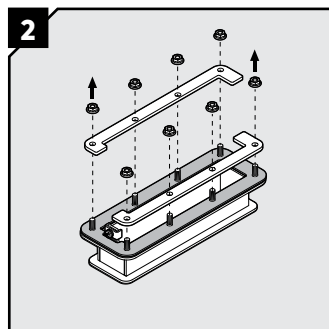

2 Remove all nuts and the two parts of the counter frame.

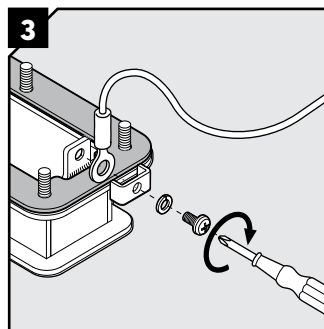

3 Attach a protective bonding conductor to the frame earthing terminal.

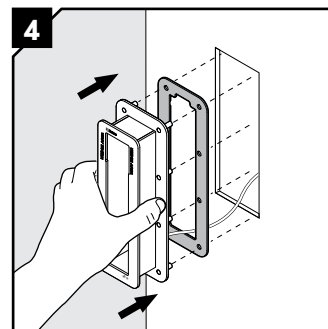

4 Insert the HD 16 Ex frame from the outside of the cabinet. Ensure that the gasket is placed between the frame and the cabinet.

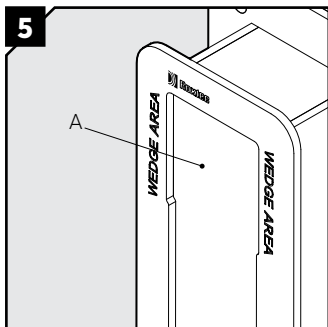

5 Observe the intended wedge area (A) without stopping edges.

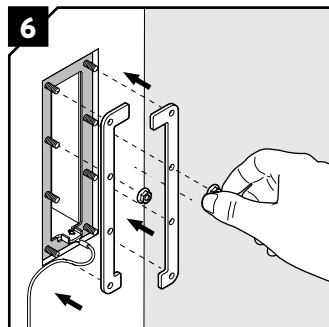

6 Attach the two parts of the counter frame from the inside of the cabinet.

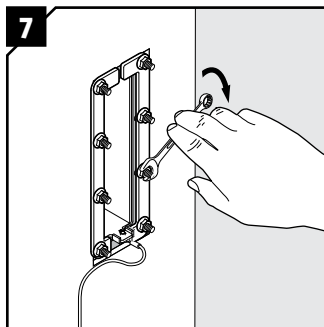

7 Tighten the nuts crosswise in small steps. Recommended torque 4 Nm. Do not overtighten the nuts.

Installation of Roxtec CX modules

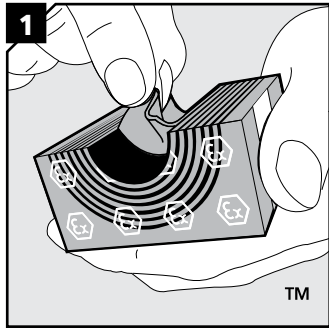

Adapt modules, which are to hold cables, by peeling off layers until you reach the gap seen in pic. 3. The number of layers may not differ by more than one between the halves.

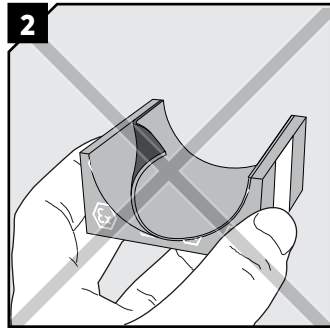

Do not remove the last layer. Do not remove the conductive tape.

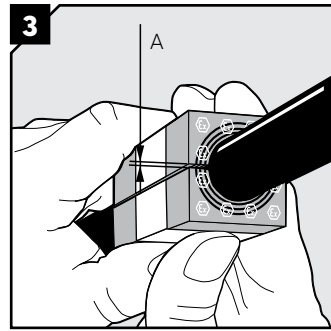

Achieve a 0.1-1.0 mm (A) gap between the two halves when held against the cable.

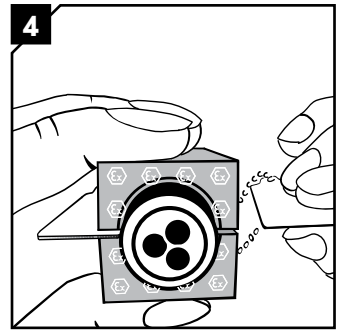

Measure the gap with the Ex Gap Gauge by holding blade one in one gap and checking the other with blade two.

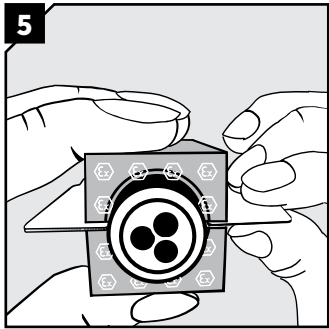

If the gap is too big, the gauge will slip in easily.

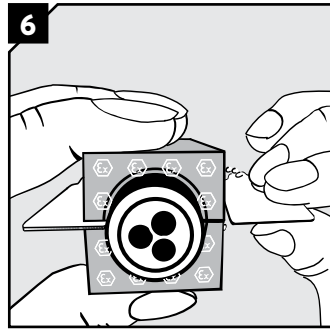

If the gap is correct, there will be no room for blade two.

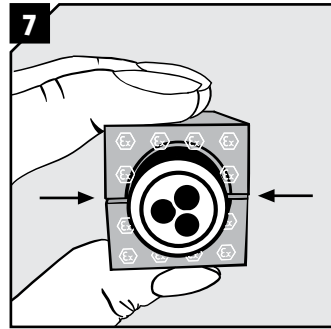

When checking without the gauge, there shall be a visual gap.

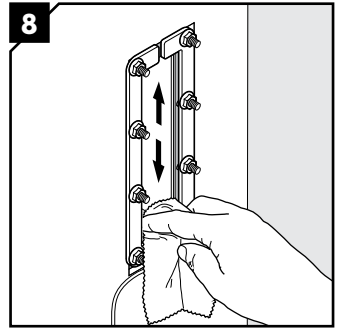

Make sure that the inside surfaces of the frame are free from dirt or dust.

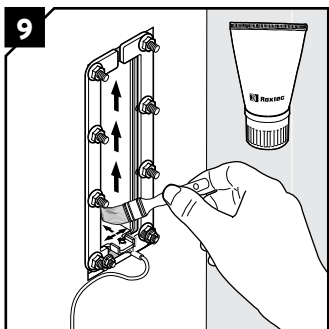

Lubricate the inside surfaces of the frame all around with Roxtec Assembly Gel Ex, especially into the corners.

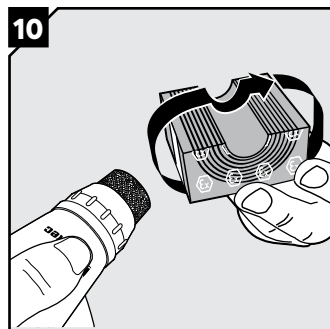

Lubricate all modules for the frame thoroughly with Roxtec Assembly Gel Ex, both the inside and the outside surfaces.

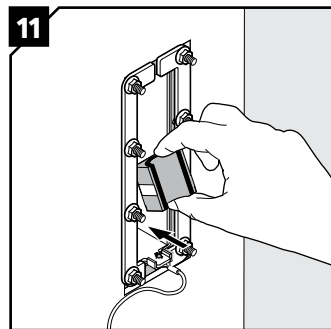

Insert the modules from the back side of the transit according to your installation plan. Start with the largest modules.

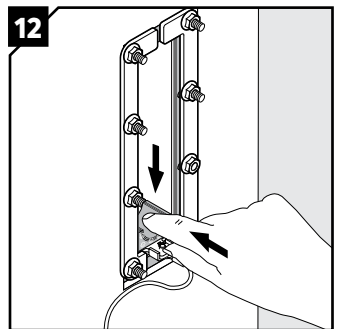

Push the modules in place. Ensure that the module rests against the stopping edge at the front.

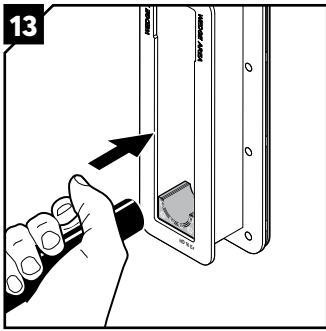

13 Insert the cables through the frame.

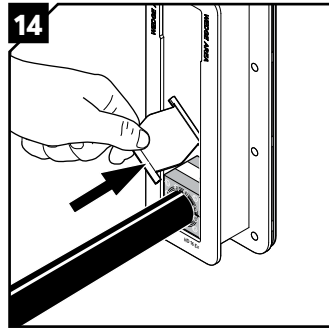

14 Insert a stayplate on top of every finished row of modules.

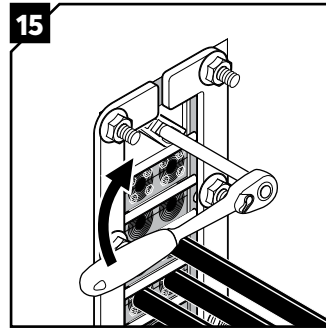

15 Use a Roxtec pre-compression tool to make space for the compression units if required.

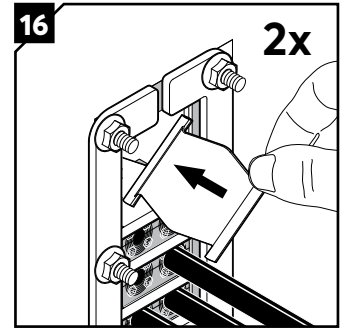

16 Before inserting the final row of modules, insert two stayplates.

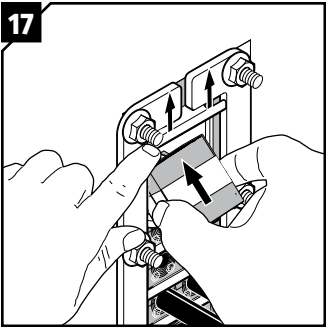

17 Lift the upper stayplate and insert the last module underneath it.

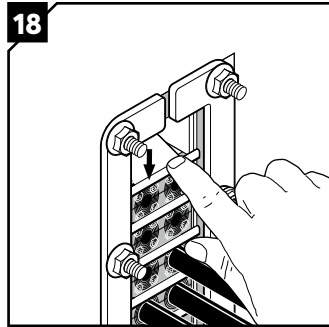

18 Drop the stayplate on top of the last row of modules. Make sure the combinations of modules equal the 160 mm packing space. See example on page 2.

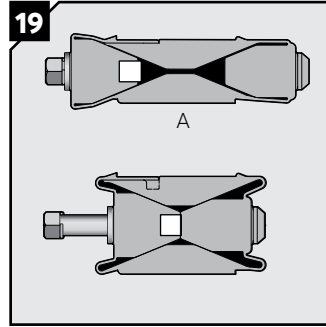

19 Ensure that the compression unit is fully uncompressed (A) by untightening the screw of the compression unit before inserting it.

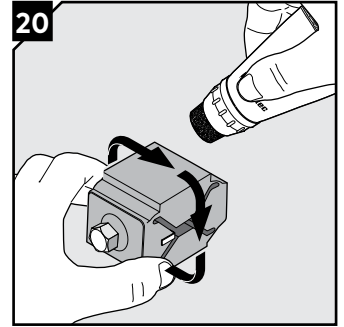

20 Lubricate the compression units on all sides with Roxtec Assembly Gel Ex.

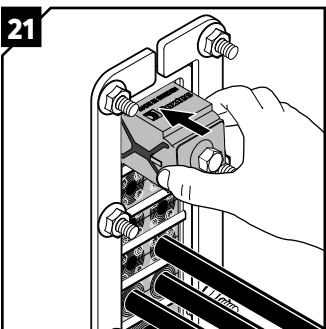

21 Insert the compression unit until stop. The compression unit can be inserted from any direction.

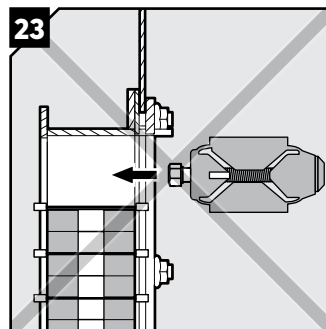
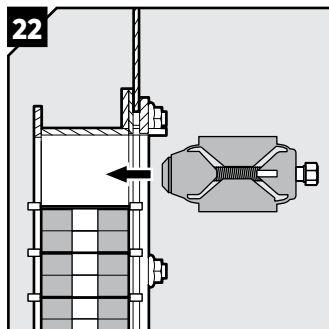

23 Do not install the compression unit with the screwhead facing the frame.

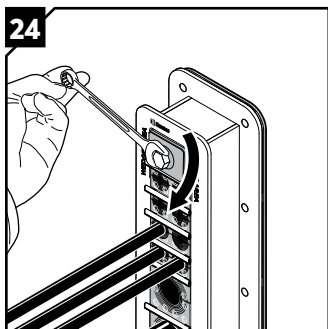

Tighten the screw of the compression unit until full stop. Do not exceed 20 Nm.

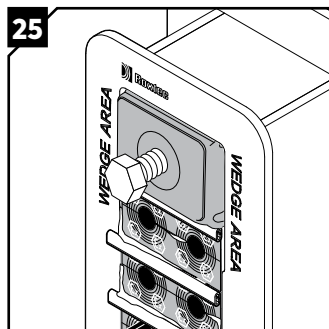

Visible excess assembly gel Ex is a sign of good compression. Make sure that all modules are placed correctly and fully inserted after compression.

Disassembly and reinstallation

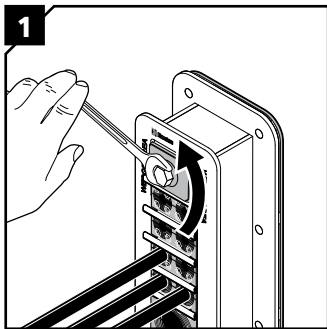

1
Untighten the screw of the compression unit.

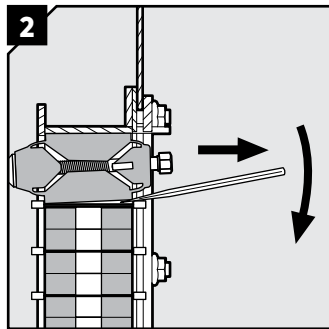

2
Insert a flat tool between the compression unit and the stayplate to simplify removal of the compression unit. Roxtec special tools are available.

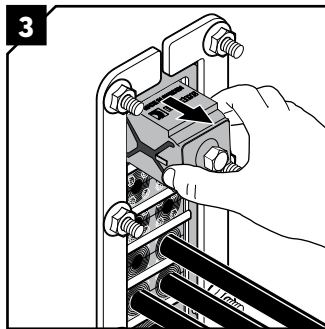

3
Remove the compression unit.

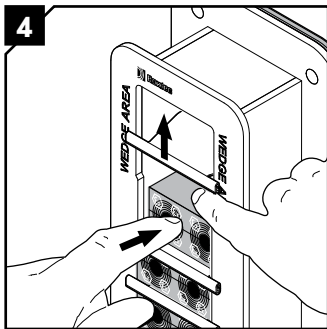

4
Lift the stayplate and push out the upper module from the front side.

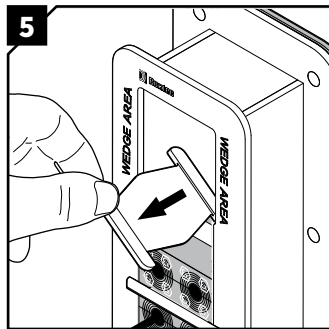

5
Remove the stayplate.

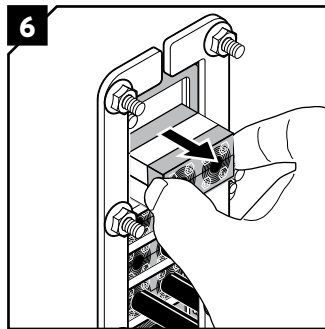

6
Continue to remove the modules by pulling them out from the backside of the frame.

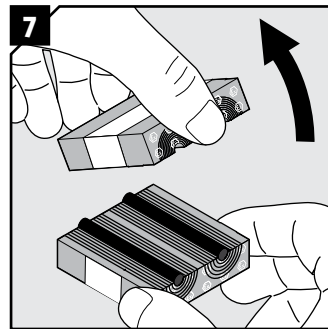

7
Separate the module halves and continue the reinstallation from step 1 on page 4.

Frame labels

Year of manufacture → XXXX



UKCA conformity marking

Can only be applied together with the ATEX and IECEx main frame label.



Note

- An incorrectly adapted module shall be replaced (layers shall not be reused).
- Temperature range -60 to +80°C.
- You find EC Type Examination certificate at www.roxtec.com, or contact your local Roxtec supplier.
- To be used with: Ex parts.
- Permitted Roxtec module types: CX and CX BG. This instruction is applicable for CX. Do not mix different module types in the same packing space.
- Cables shall go straight through the frame.

The following conditions for safe use shall be considered according to the EC Type Examination certificate and the IECEx Certificate of Conformity:

- For maintaining the explosion protection, the installation instructions that accompany the products shall be considered.
- Only cable for fixed installation is permitted for the cable entry.
- For optimum reliability, wait 24 hours or longer after installation before exposing the cables/pipes to strain or pressure.
- The cables shall have sufficient clamping to ensure that no pulling or twisting will be transmitted to the terminals.
- Cable transit devices must be installed in accordance with the applicable local electrical code and final acceptance is subject to inspection by the local authority having jurisdiction.

DISCLAIMER

"The Roxtec cable entry sealing system ("the Roxtec system") is a modular-based system of sealing products consisting of different components. Each and every one of the components is necessary for the best performance of the Roxtec system. The Roxtec system has been certified to resist a number of different hazards. Any such certification, and the ability of the Roxtec system to resist such hazards, is dependent on all components that are installed as a part of the Roxtec system. Thus, the certification is not valid and does not apply unless all components installed as part of the Roxtec system are manufactured by or under license from Roxtec ("authorized manufacturer"). Roxtec gives no performance guarantee with respect to the Roxtec system, unless (I) all components installed as part of the Roxtec system are manufactured by an authorized manufacturer and (II) the purchaser is in compliance with (a), and (b), below.
 (a) During storage, the Roxtec system or part thereof, shall be kept indoors in its original packaging at room temperature.
 (b) Installation shall be carried out in accordance with Roxtec installation instructions in effect from time to time.

The product information provided by Roxtec does not release the purchaser of the Roxtec system, or part thereof, from the obligation to independently determine the suitability of the products for the intended process, installation and/or use.
 Roxtec gives no guarantee for the Roxtec system or any part thereof and assumes no liability for any loss or damage whatsoever, whether direct, indirect, consequential, loss of profit or otherwise, occurred or caused by the Roxtec systems or installations containing components not manufactured by an authorized manufacturer and/or occurred or caused by the use of the Roxtec system in a manner or for an application other than for which the Roxtec system was designed or intended.
 Roxtec expressly excludes any implied warranties of merchantability and fitness for a particular purpose and all other express or implied representations and warranties provided by statute or common law. User determines suitability of the Roxtec system for intended use and assumes all risk and liability in connection therewith. In no event shall Roxtec be liable for indirect, consequential, punitive, special, exemplary or incidental damages or losses.*



Roxtec International AB
 Box 540, 371 23 Karlskrona, SWEDEN
 PHONE +46 455 36 67 00, FAX +46 455 820 12
 EMAIL info@roxtec.com, www.roxtec.com