

## Safety information

Roxtec recommends that all installations are performed without facility operation. Follow national regulations and installation codes. Any action affecting the routed service should be performed according to manufacturer recommendations.

## General information

Installation and maintenance:  
For European member countries of CENELEC, standards EN 60079-14 and EN 60079-17 shall be considered. For countries members of IECEx, standards IEC 60079-14 and IEC 60079-17 shall be considered. For other countries, applicable national regulation shall be considered.

The products fulfill the following standards:

EN IEC 60079-0:2018 (IEC 60079-0:2017)  
EN 60079-7:2015/A1:2018 (IEC 60079-7:2015/A1:2018)  
EN 60079-31:2014 (IEC 60079-31:2013)

CSA Std. C22.2 No. 18.3-12  
CSA Std. C22.2 No. 94.2-15  
CAN-CSA C22.2 No. 60079-0: 15  
CAN-CSA C22.2 No. 60079-7: 16  
CAN/CSA C22.2 No. 60079-31: 15

UL Standard 514B, 6th Ed.  
UL Standard 50E, 2nd Ed  
UL 60079-0 - 6th Ed.  
UL 60079-7 - 5th Ed  
UL 60079-31 - 2nd Ed

The cable transit devices are intended for use with permanently installed circular cross-section cables, with or without armoring or braided screen. Cable transit devices may also be used with permanently installed cables of types TECK90 according to standard C22.2 No. 131-07, ACWU according to standard UL4, MC according to standard UL1569 and ACIC cables according to CSA C22.1-06 CEC, UL 444, UL 1685, UL 13, UL2250, IEC 61158-2.



## Installation instructions Roxtec HDLC Ex with Roxtec RMX modules

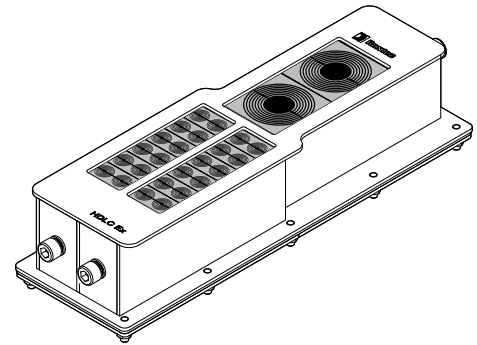

Configuration example  
HDLC 24+2 Ex

## Components

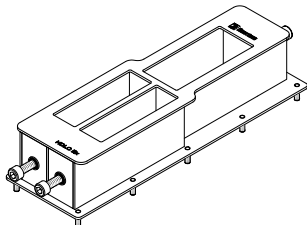

HDLC Ex frame  
incl. fasteners

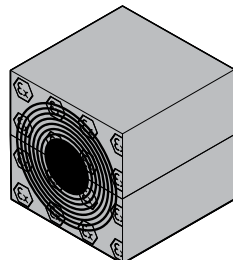

RMX module

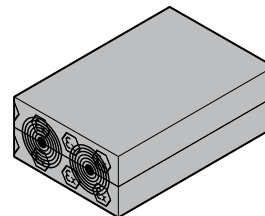

RMX module

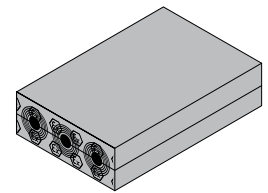

RMX module

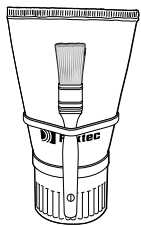

Assembly gel Ex

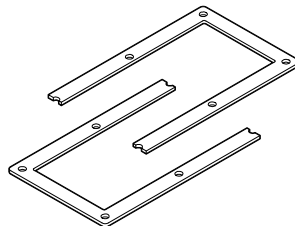

HDLC Ex counter frame

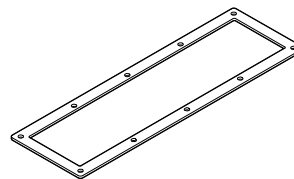

HDLC Ex gasket

## Adaptable Roxtec RMX modules

Module	Number of cables/pipes	For cable/pipe Ø (mm)	Packing space
RMX 15w40	3	0+4-9.5	B
RMX 20w40	2	0+4-15.5	B
RMX 30w40	1	0+10-24	B
RMX 40	1	0+21.5-33.5	B
RMX 40 10-31	1	0+9.5-31	B
RMX 30	1	0+10-24	A
RMX 60	1	0+24-52	A

## Single diameter RMX modules

Module	Number of cables/pipes	For cable/pipe Ø (mm)	Packing space
RMX 20w40/16,5	2	16.5	B
RMX 60/54	1	54	A

## Solid compensation RMX modules

Module	Number of cables/pipes	For cable/pipe diameter Ø (mm)	Packing space
RMX 5w40/0	-	-	B
RMX 10w40/0	-	-	B

## Packing space

All measures in (mm).

### Example of module configuration:

The packing height is 120 mm for all three openings.

The combined height of modules for one opening must be equal to the packing height of 120 mm.

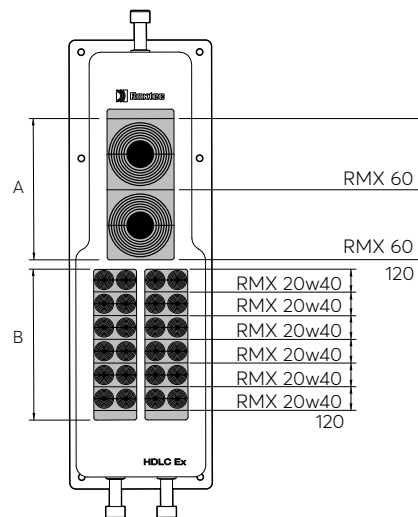

## Tools

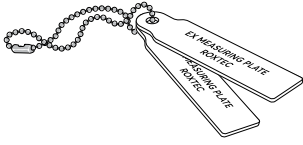

Roxtec Ex Gap Gauge

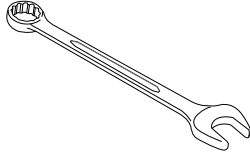

Spanner  
10 mm  
(not included)

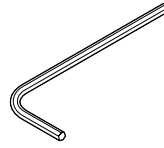

Allen key  
(not included)

## Aperture dimensions in cabinet

All measures in (mm).

Max wall/cabinet thickness: 5 mm

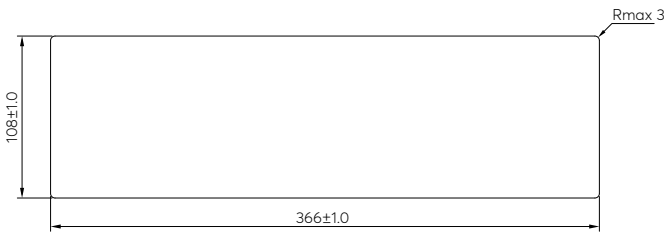

# Installation

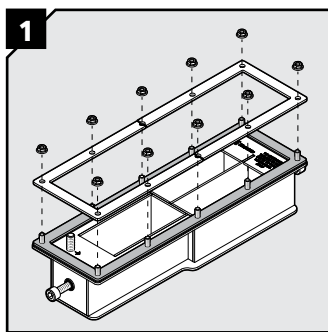

1 Remove all nuts and the two parts of the counter frame.

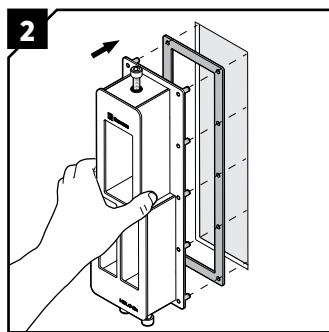

2 Insert the HDLC Ex frame from the outside of the cabinet. Ensure that the gasket is placed between the frame and the cabinet.

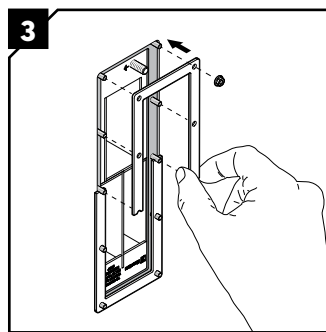

3 Attach the two parts of the counter frame and the nuts from the inside of the cabinet.

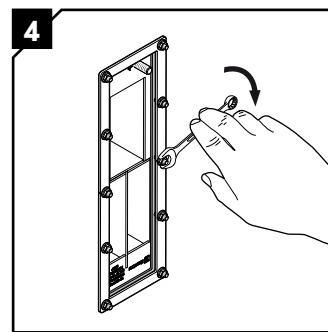

4 Tighten the nuts crosswise in small steps. Recommended torque 4 Nm. Do not overtighten.

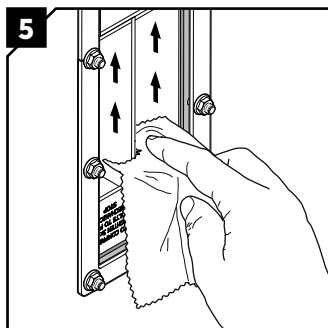

5 Clean the inside surfaces of the frame.

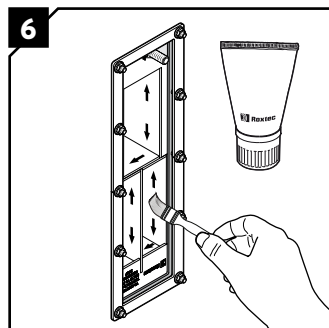

6 Lubricate the inside surfaces all around with Roxtec Assembly Gel Ex, especially into the corners.

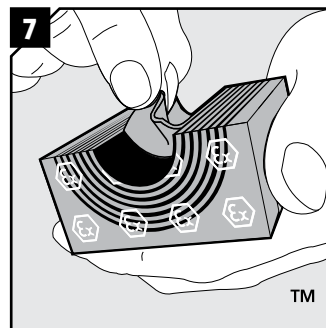

7 Adapt modules, which are to hold cables, by peeling off layers until you reach the gap seen in step 9. The number of layers may not differ by more than one between the halves.

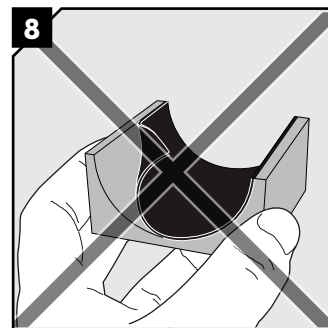

8 Do not remove the last layer.

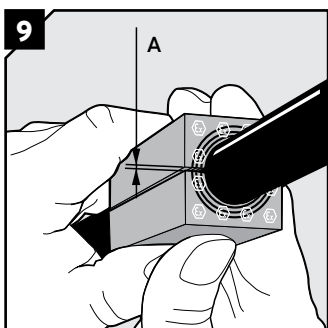

9 Achieve a 0.1-1.0 mm gap (A) between the two halves when held against the cable.

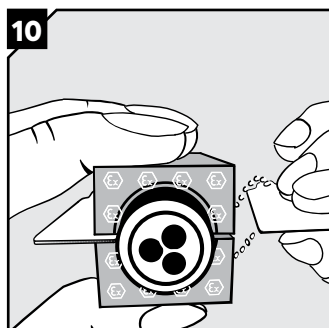

10 Measure the gap with the Roxtec Ex Gap Gauge by holding blade one in one gap and checking the other with blade two.

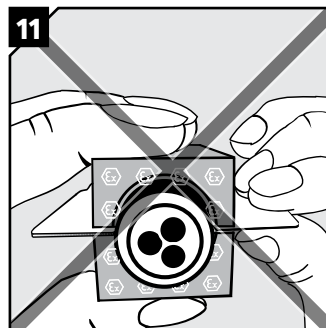

11 If the gap is too big, blade two will slip in easily.

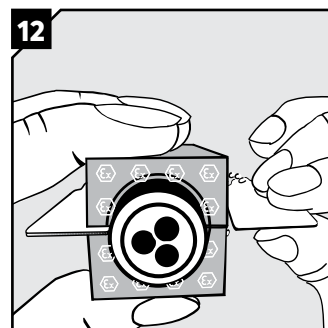

12 If the gap is correct, there will be no room for blade two.

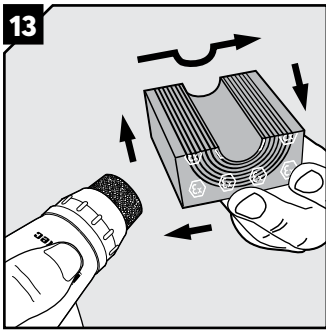

Lubricate all modules thoroughly with Roxtec Assembly Gel Ex, both the inside and the outside sealing surfaces.

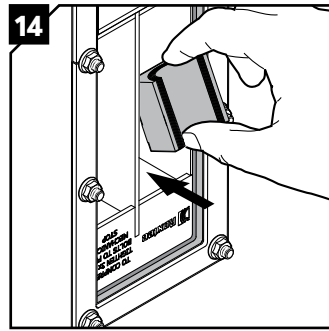

Insert the modules from the back side of the transit according to your packing plan. Start with the largest modules.

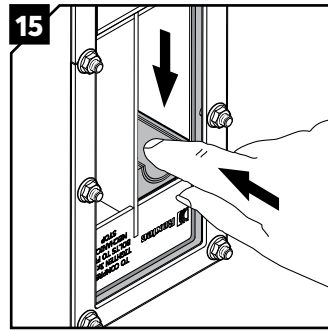

Push the modules in place. Ensure that the module rests against the stopping edge at the front.

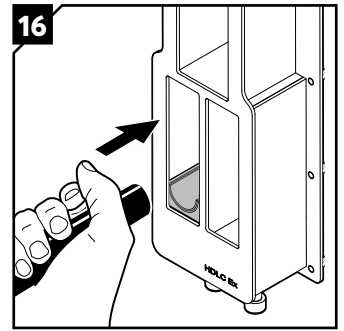

Insert the cables through the frame.

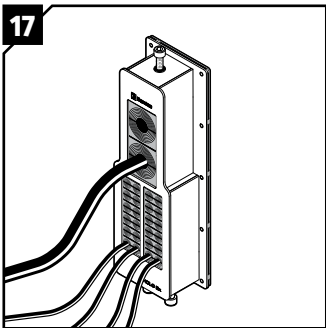

Continue to fill up the packing space according to your packing plan. Ensure that the combined height of modules equals the packing height of 120 mm.

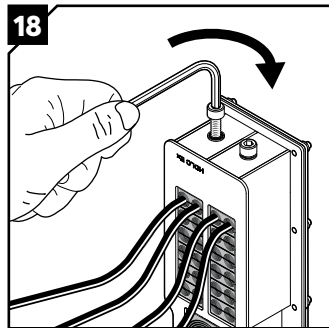

Tighten the 3 screws of the compression units until full mechanical stop. Do not exceed 20 Nm.

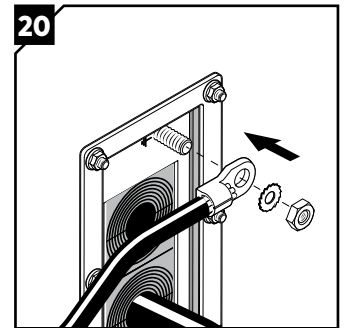
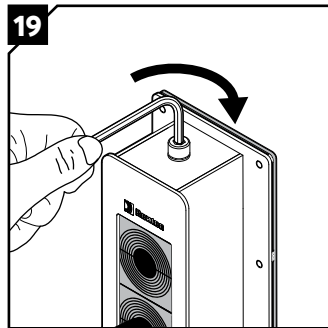

Attach a protective bonding conductor to the frame earthing terminal.

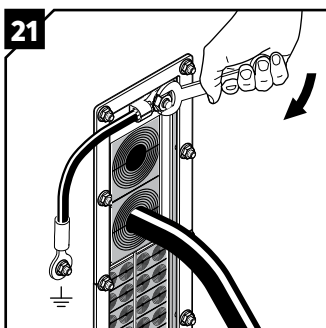

Tighten the nut firmly. Ensure electrical contact to protective earth. National regulation applies.

## Disassembly and reinstallation

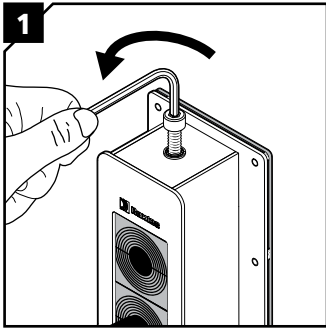

Release the compression by loosening the screws.

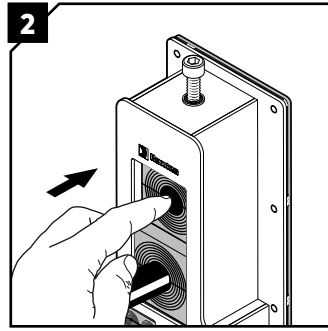

Push out the modules from the front side.

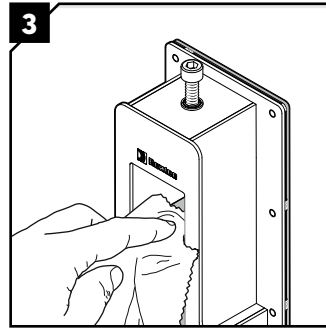

Make sure that the inside surfaces of the exposed packing space are free from dirt or dust.

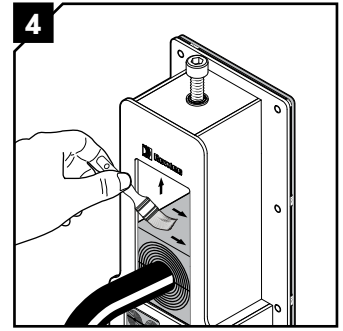

Lubricate the inside surfaces all around with Roxtec Assembly Gel Ex, especially into the corners. Continue the reinstallation from step 7.



## Note

- An incorrectly adapted module shall be replaced (layers shall not be reused).
- Temperature range -60 to +80°C.
- You find EC Type Examination certificate at [www.roxtec.com](http://www.roxtec.com), or contact your local Roxtec supplier.
- To be used with: Ex parts.
- Permitted Roxtec module types: RMX and RX BG B. These instructions are applicable for RMX modules.  
Do not mix modules of different types in the same packing space.
- Cables shall go straight through the frame.

The following conditions for safe use shall be considered according to the EC Type Examination certificate and the IECEx Certificate of Conformity:

- For maintaining the explosion protection, the installation instructions that accompany the products shall be considered.
- Only cable for fixed installation is permitted for the cable entry.
- For optimum reliability, wait 24 hours or longer after installation before exposing the cables/pipes to strain or pressure.
- The cables shall have sufficient clamping to ensure that no pulling or twisting will be transmitted to the terminals.
- Cable transit devices must be installed in accordance with the applicable local electrical code and final acceptance is subject to inspection by the local authority having jurisdiction.

## Frame label:

Year of manufacture

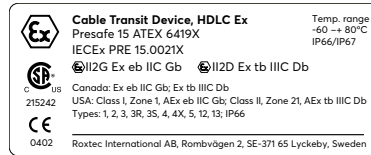
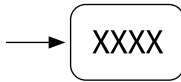

## DISCLAIMER

"The Roxtec cable entry sealing system ("the Roxtec system") is a modular-based system of sealing products consisting of different components. Each and every one of the components is necessary for the best performance of the Roxtec system. The Roxtec system has been certified to resist a number of different hazards. Any such certification, and the ability of the Roxtec system to resist such hazards, is dependent on all components that are installed as a part of the Roxtec system. Thus, the certification is not valid and does not apply unless all components installed as part of the Roxtec system are manufactured by or under license from Roxtec ("authorized manufacturer"). Roxtec gives no performance guarantee with respect to the Roxtec system, unless (I) all components installed as part of the Roxtec system are manufactured by an authorized manufacturer and (II) the purchaser is in compliance with (a), and (b), below.  
(a) During storage, the Roxtec system or part thereof, shall be kept indoors in its original packaging at room temperature.  
(b) Installation shall be carried out in accordance with Roxtec installation instructions in effect from time to time.

The product information provided by Roxtec does not release the purchaser of the Roxtec system, or part thereof, from the obligation to independently determine the suitability of the products for the intended process, installation and/or use.  
Roxtec gives no guarantee for the Roxtec system or any part thereof and assumes no liability for any loss or damage whatsoever, whether direct, indirect, consequential, loss of profit or otherwise, occurred or caused by the Roxtec systems or installations containing components not manufactured by an authorized manufacturer and/or occurred or caused by the use of the Roxtec system in a manner or for an application other than for which the Roxtec system was designed or intended.  
Roxtec expressly excludes any implied warranties of merchantability and fitness for a particular purpose and all other express or implied representations and warranties provided by statute or common law. User determines suitability of the Roxtec system for intended use and assumes all risk and liability in connection therewith. In no event shall Roxtec be liable for indirect, consequential, punitive, special, exemplary or incidental damages or losses.\*



**Roxtec International AB**  
 Box 540, 371 23 Karlskrona, SWEDEN  
 PHONE +46 455 36 67 00, FAX +46 455 820 12  
 EMAIL [info@roxtec.com](mailto:info@roxtec.com), [www.roxtec.com](http://www.roxtec.com)