

Installation instructions Roxtec CRL 4" and 5"

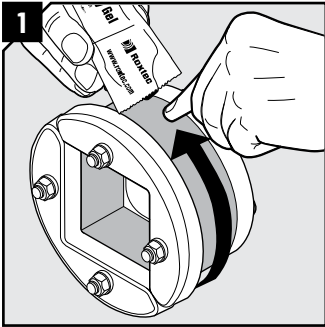

1 Lubricate the frame sparsely on the outside black rubber part with Roxtec Assembly Gel.

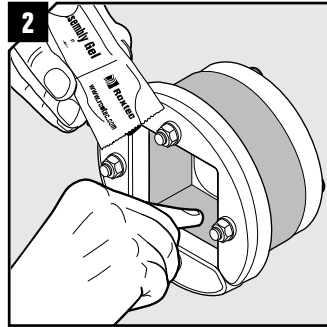

2 Lubricate the inside faces of the frame thoroughly, especially into the corners.

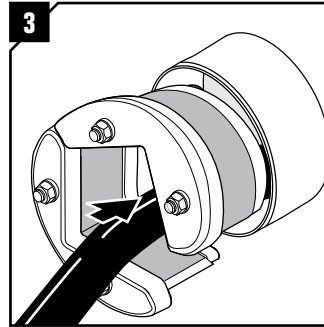

3 Insert the frame into the sleeve opening.

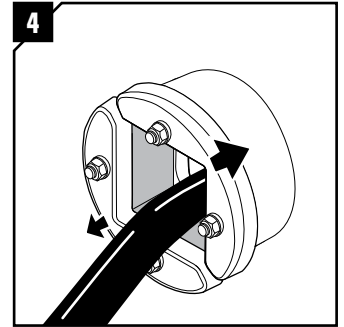

4 Loosen the nuts and push the front fittings to the sides.

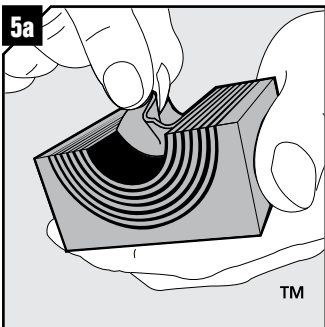

5a Adapt modules which are to hold cables or pipes by peeling off layers until you reach the gap seen in pic. 5b.

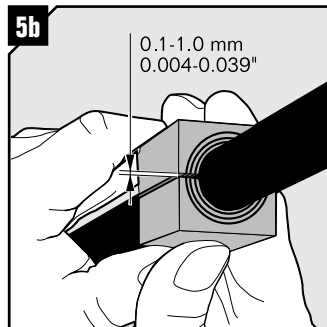

5b Achieve a 0.1-1.0 mm gap between the two halves when held against the cable/pipe.

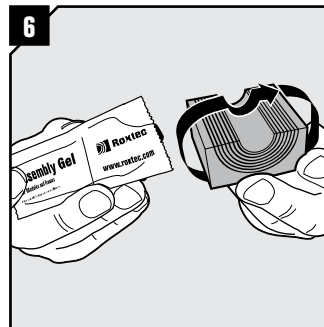

6 Lubricate all modules for the frame thoroughly, both the inside and the outside surfaces.

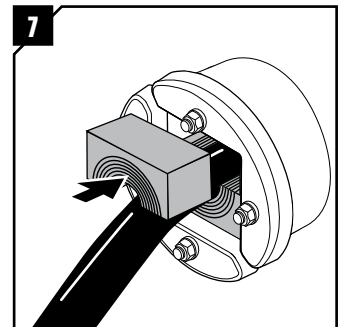

7 Insert the modules in the frame.

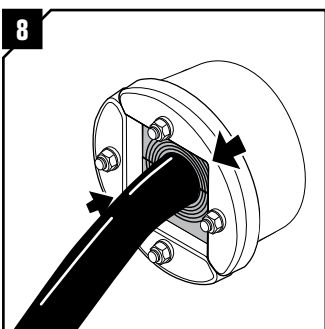

8 Push the front fittings back towards the centre.

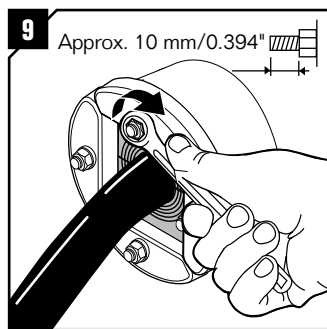

9 Tighten the nuts.
Max torque is 2 Nm/1.48 lbf-ft.

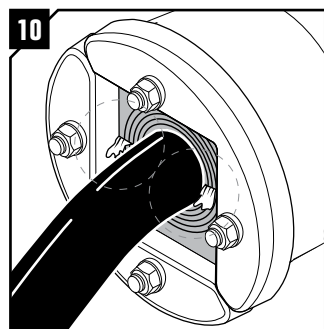

10 Excess Assembly Gel will protrude when tightening the seal.

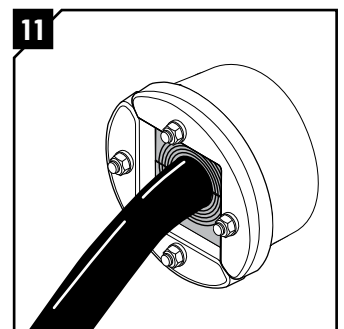

11 The installation is complete.

Disassembly

Reverse order

Note

- For optimum reliability, wait 24 hours or longer after installation before exposing the cables/pipes to strain or pressure.
- Cables/pipes shall be routed perpendicularly to the wall.

Roxtec CRL kits

For 1 cable

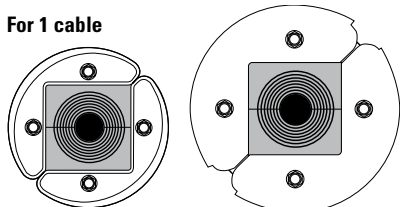

Roxtec CRL 4"/1

Roxtec CRL 5"/1

Pcs	Module	For cable diameter	
		(mm)	(in)
1	CM 66	0+24-54	0+0.945-2.126

For 4 cables

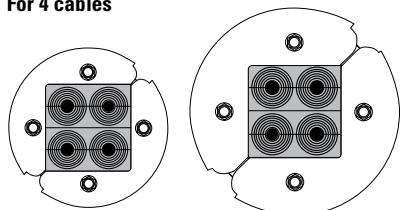

Roxtec CRL 4"/4

Roxtec CRL 5"/4

Pcs	Module	For cable diameter	
		(mm)	(in)
2	CM 33w66	2x0+10-29	2x0+0.394-1.142

For 5 cables

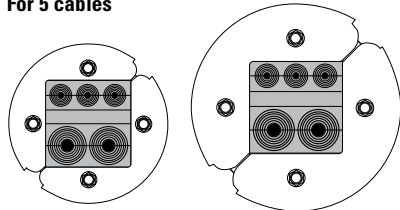

Roxtec CRL 4"/5

Roxtec CRL 5"/5

Pcs	Module	For cable diameter	
		(mm)	(in)
1	CM 22w66	3x0+4-16.5	3x0+0.157-0.650
1	CM 11/0		
1	CM 33w66	2x0+10-29	2x0+0.394-1.142

For 9 cables

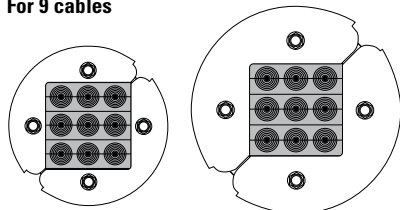

Roxtec CRL 4"/9

Roxtec CRL 5"/9

Pcs	Module	For cable diameter	
		(mm)	(in)
3	CM 22w66	3x0+4-16.5	3x0+0.157-0.650

- All kits include Roxtec Assembly Gel and installation instructions.

DISCLAIMER

"The Roxtec cable entry sealing system ("the Roxtec system") is a modular-based system of sealing products consisting of different components. Each and every one of the components is necessary for the best performance of the Roxtec system. The Roxtec system has been certified to resist a number of different hazards. Any such certification, and the ability of the Roxtec system to resist such hazards, is dependent on all components that are installed as part of the Roxtec system. Thus, the certification is not valid and does not apply unless all components installed as part of the Roxtec system are manufactured by or under license from Roxtec ("authorized manufacturer"). Roxtec gives no performance guarantee with respect to the Roxtec system, unless (I) all components installed as part of the Roxtec system are manufactured by an authorized manufacturer and (II) the purchaser is in compliance with (a), and (b), below.

(a) During storage, the Roxtec system or part thereof, shall be kept indoors in its original packaging at room temperature.

(b) Installation shall be carried out in accordance with Roxtec installation instructions in effect from time to time.

The product information provided by Roxtec does not release the purchaser of the Roxtec system, or part thereof, from the obligation to independently determine the suitability of the products for the intended process, installation and/or use.

Roxtec gives no guarantee for the Roxtec system or any part thereof and assumes no liability for any loss or damage whatsoever, whether direct, indirect, consequential, loss of profit or otherwise, occurred or caused by the Roxtec systems or installations containing components not manufactured by an authorized manufacturer and/or occurred or caused by the use of the Roxtec system in a manner or for an application other than for which the Roxtec system was designed or intended.

Roxtec expressly excludes any implied warranties of merchantability and fitness for a particular purpose and all other express or implied representations and warranties provided by statute or common law. User determines suitability of the Roxtec system for intended use and assumes all risk and liability in connection therewith. In no event shall Roxtec be liable for indirect, consequential, punitive, special, exemplary or incidental damages or losses."



Roxtec International AB
 Box 540, 371 23 Karlskrona, SWEDEN
 PHONE +46 455 36 67 00, FAX +46 455 820 12
 EMAIL info@roxtec.com, www.roxtec.com