

Safety information

Roxtec recommends that all installations are performed without facility operation. Follow national regulations and installation codes. Any action affecting the routed service should be performed according to manufacturer recommendations.

General information

Installation and maintenance:
For European member countries of CENELEC, standards EN 60079-14 and EN 60079-17 shall be considered. For countries members of IECEx, standards IEC 60079-14 and IEC 60079-17 shall be considered. For other countries, applicable national regulation shall be considered.

The products fulfill the following standards:

EN IEC 60079-0:2018 (IEC 60079-0:2017)
EN 60079-7:2015/A1:2018 (IEC 60079-7:2015/A1:2018)
EN 60079-31:2014 (IEC 60079-31:2013)

CSA Std. C22.2 No. 18.3-12
CSA Std. C22.2 No. 94.2-15
CAN-CSA C22.2 No. 60079-0: 15
CAN-CSA C22.2 No. 60079-7: 16
CAN/CSA C22.2 No. 60079-31: 15

UL Standard 514B, 6th Ed.
UL Standard 50E, 2nd Ed
UL 60079-0 - 6th Ed.
UL 60079-7 - 5th Ed
UL 60079-31 - 2nd Ed

The cable transit devices are intended for use with permanently installed circular cross-section cables, with or without armoring or braided screen. Cable transit devices may also be used with permanently installed cables of types TECK90 according to standard C22.2 No. 131-07, ACWU according to standard UL4, MC according to standard UL1569 and ACIC cables according to CSA C22.1-06 CEC, UL 444, UL 1685, UL 13, UL2250, IEC 61158-2.



Installation instructions Roxtec HD 32 Ex with Roxtec CX BG™ modules

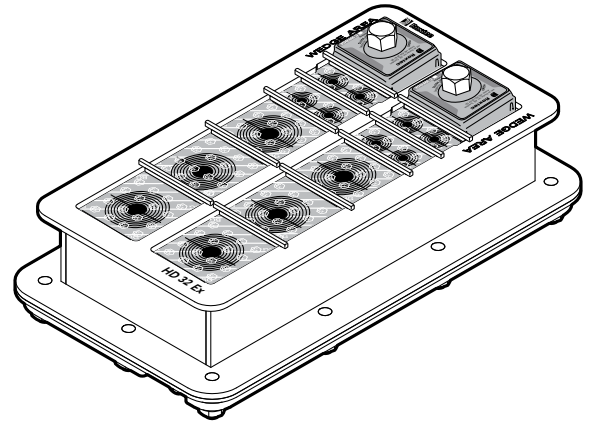

Components

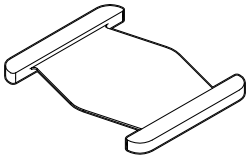

Stayplate Ex

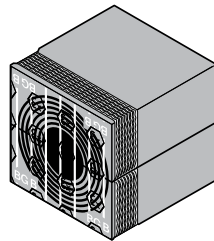

CX BG modules

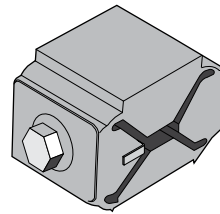

Compression unit
C Wedge 40 Ex AISI 316

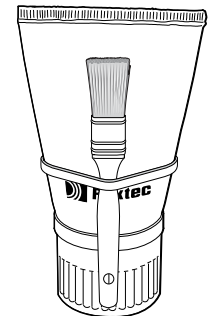

Assembly gel Ex

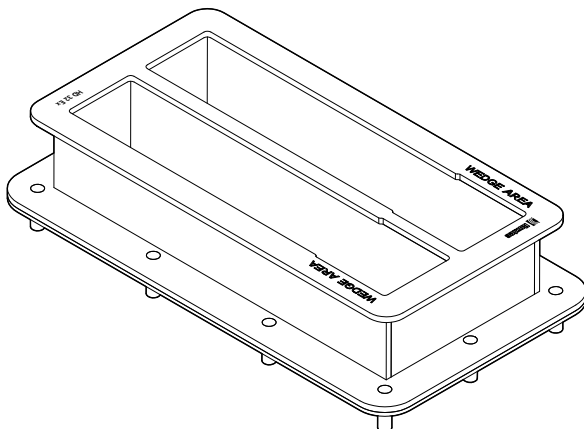

HD 32 Ex frame

Aperture dimensions in cabinet

Max wall/cabinet thickness: 4 mm (0.157")

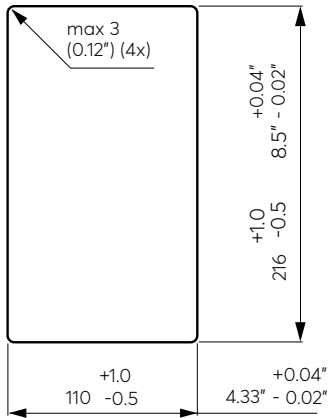

Packing space

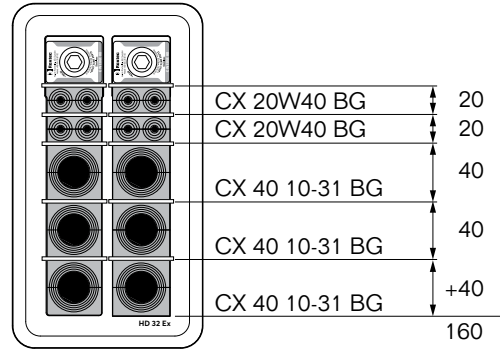

As module installation example shows, 160 mm can be the result of 3 pieces of CX 40 10-32 BG and 2 pieces of CX 20W40 BG. Different module configurations must be totally 160 mm.

Adaptable CX BG™ modules

Module	Number of cables/pipes	For cable/pipe diameter		Total braid cross-section/cable sq mm	Approx. Eqv. AWG
		a-b (mm)	a-b (in)		
CX 20w40 BG	2	0+4.0–15.5	0+0.157–0.610	4*	11*
CX 30w40 BG	1	0+10.0–24.0	0+0.394–0.945	13	6
CX 40 10–31 BG	1	0+9.5–31.0	0+0.374–1.220	21	4
CX 40 BG	1	0+21.5.0–33.5	0+0.846–1.319	21	4

* Per cable.

Solid compensation modules CX BG™

Module
CX 10w40/0 BG
CX 20/0 BG
CX 40/0 BG

Frame label:

Year of manufacture → **XXXX**

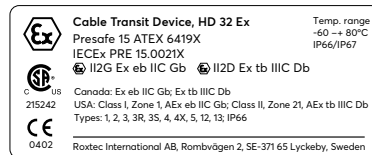

Note

- An incorrectly adapted module shall be replaced (layers shall not be reused).
- Temperature range -60 to +80°C.
- You find EC Type Examination certificate at www.roxtec.com, or contact your local Roxtec supplier.
- To be used with: Ex parts.
- Permitted Roxtec module types: CX and CX BG. This instruction is applicable for CX BG. Do not mix different module types in the same packing space.
- Cables shall go straight through the frame.

The following conditions for safe use shall be considered according to the EC Type Examination certificate and the IECEx Certificate of Conformity:

- For maintaining the explosion protection, the installation instructions that accompany the products shall be considered.
- Only cable for fixed installation is permitted for the cable entry.
- For optimum reliability, wait 24 hours or longer after installation before exposing the cables/pipes to strain or pressure.
- The cables shall have sufficient clamping to ensure that no pulling or twisting will be transmitted to the terminals.
- Cable transit devices must be installed in accordance with the applicable local electrical code and final acceptance is subject to inspection by the local authority having jurisdiction.

Installation of HD 32 Ex frame

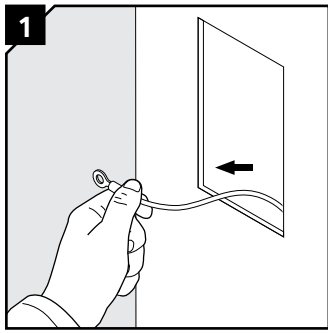

Route the earth cable through the aperture.

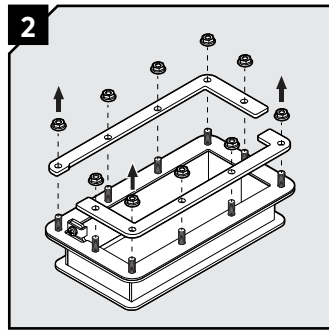

Remove all nuts and the two parts of the counter frame.

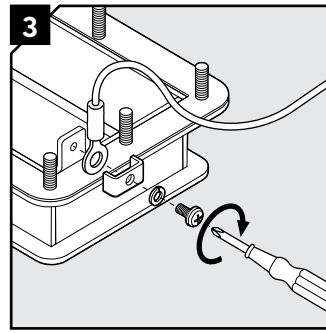

Attach the earth cable to the earth stud.

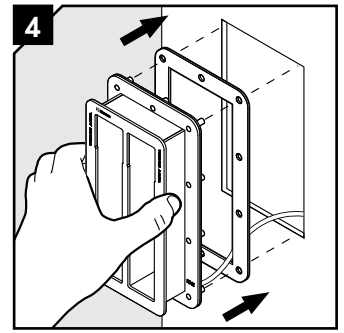

Insert the HD 32 Ex frame from the outside of the cabinet. Ensure that the gasket is placed between the frame and the cabinet.

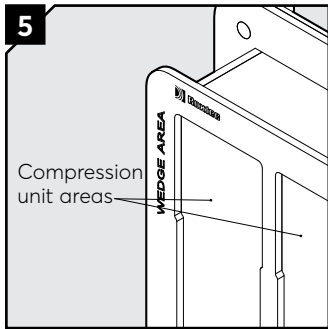

Observe the intended wedge areas without stopping edges.

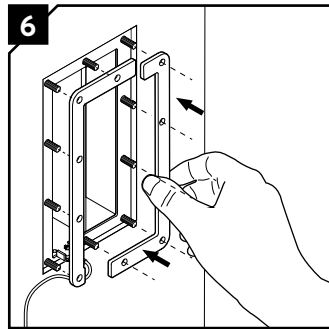

Attach the two parts of the counter frame from the inside of the cabinet.

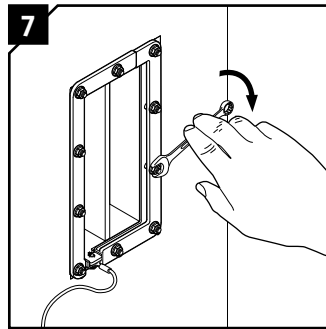

Tighten the nuts crosswise in small steps. Recommended torque 4 Nm. Do not overtighten the nuts.

Installation of Roxtec CX BG™ modules

Integrated environmental sealing system for bonding and grounding applications. For use with armored/shielded jacketed cables including smooth and corrugated cables such as interlocked and continuous welded metal clad cables or wired and braided cables. For approvals, see www.roxtec.com.

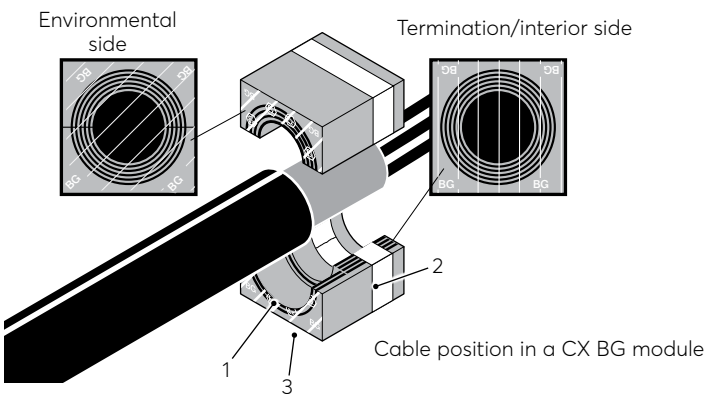

1. Multidiameter™ – adapts to cables and pipes of different sizes through removable layers
2. Bonding/grounding braid
3. Environmental side
4. Conductors
5. Cable armor/shield
6. Cable outer sheath

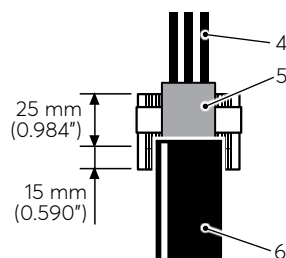

Note: For non-armored/shielded cables. Cable sheath is not removed. No bonding/grounding will be achieved.

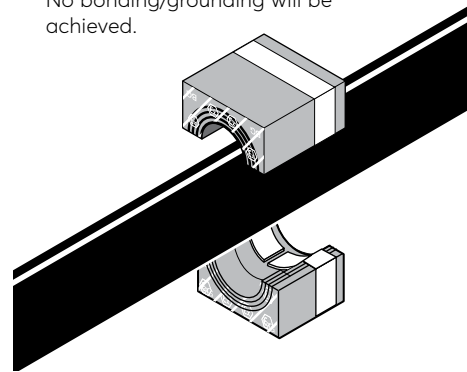

See page 6 - 9 for cable preparation alternatives. For non armored/shielded cables go to step 3b on next page.

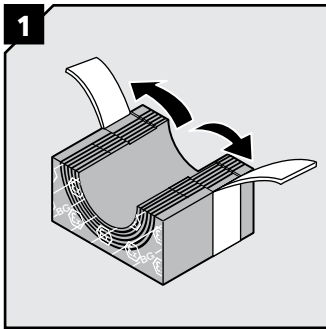

Remove the core and fold out the braid on modules that are to hold cables or pipes.

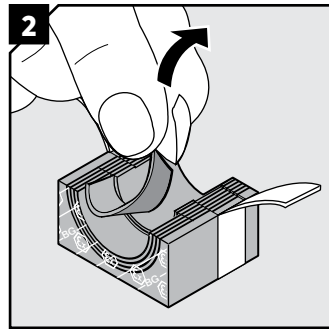

Adapt layers on the environmental protection side to the cable sheath. **NOTE:** The number of layers may not differ by more than one between the halves.

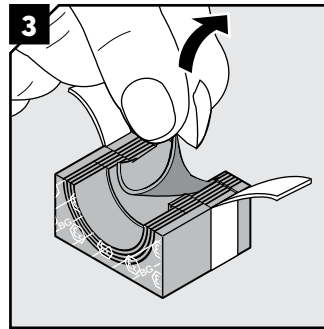

Adapt layers on the termination side to the cable screen/armor. **NOTE:** The number of layers may not differ by more than one between the halves.

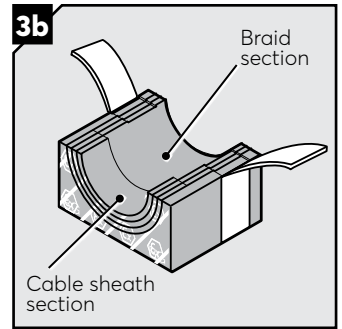

For non armored/shielded cables. Adapt the section corresponding to cable outer sheath. Adapt the braid section on both module halves by removing one layer more than on the cable sheath section.

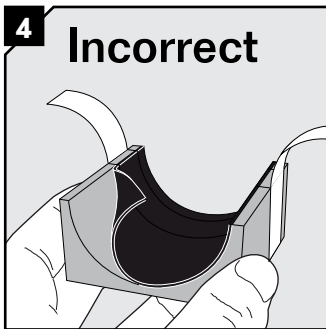

Do not remove the last layer.

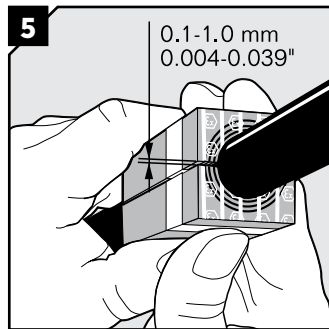

Achieve a 0.1-1.0 mm gap between the two halves when held against the cable or pipe.

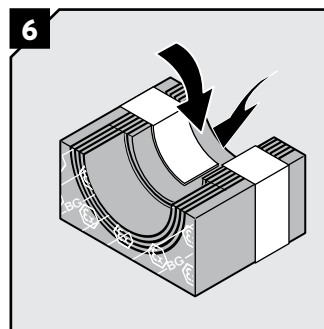

Fold the braid tightly inside the module.

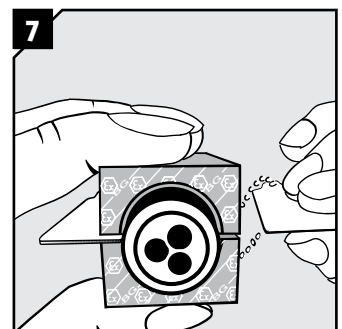

Measure the gap with the Ex Gap Gauge by holding blade one in one gap and checking the other with blade two.

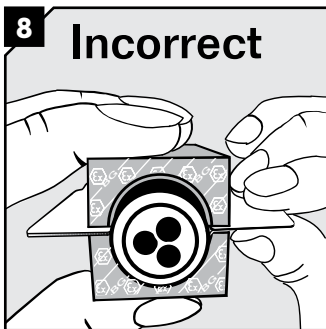

If the gap is too big, the gauge will slip in easily.

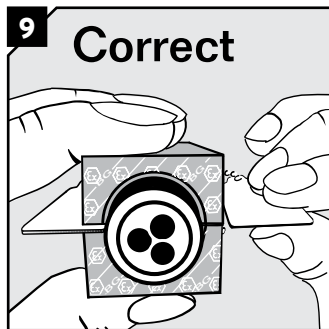

If the gap is correct, there will be no room for blade two.

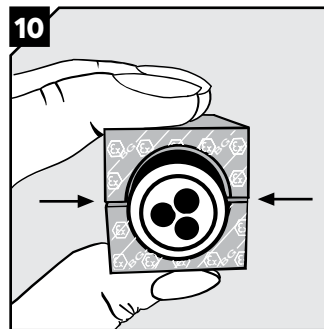

When checking without the gauge, there shall be a visual gap.

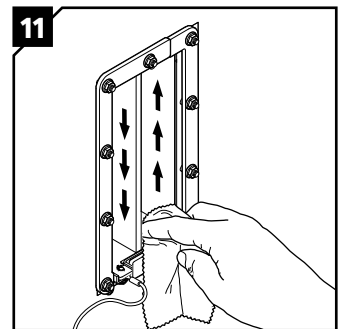

Make sure that the inside surfaces of the frame are free from dirt or dust.

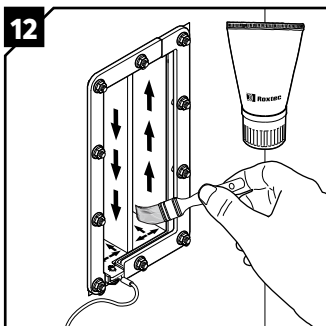

Lubricate the inside surfaces of the frame all around with Roxtec Assembly Gel Ex, especially into the corners.

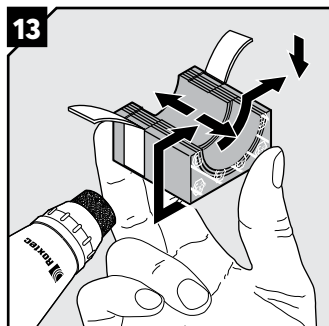

Lubricate all modules for the frame thoroughly, both the inside and the outside surfaces with Roxtec Assembly Gel Ex. Avoid excess lubricant on the braid.

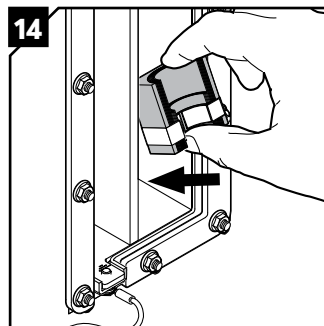

Insert the modules at an angle from the back side of the transit according to your installation plan (transit plan). Start with the largest modules.

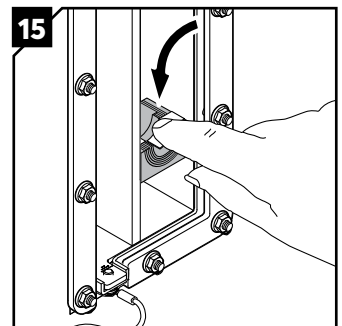

Turn the modules in line with the frame.

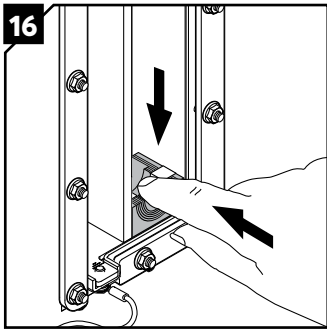

16 Push the modules in place. Ensure that the module rests against the stopping edge at the front.

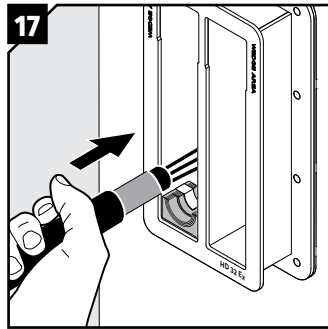

17 Insert the cables through the frame.

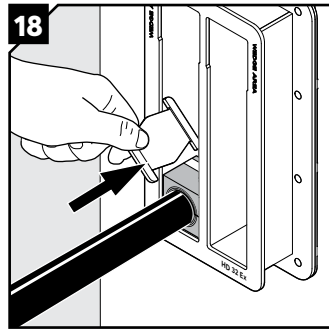

18 Insert a stayplate on top of every finished row of modules.

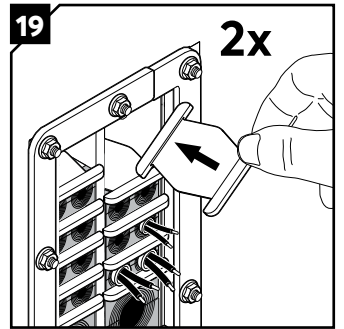

19 Before inserting the final module, insert two stayplates.

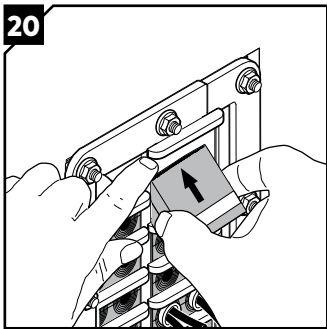

20 Lift up the stayplate and insert the last module underneath it.

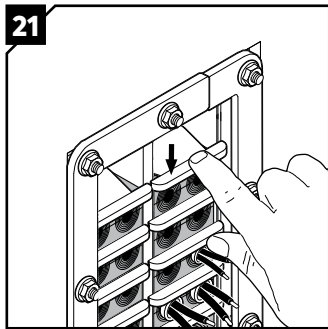

21 Drop the stayplate on top of the last row of modules. Make sure the combinations of modules equal to the 160 mm packing space. See example on page 2.

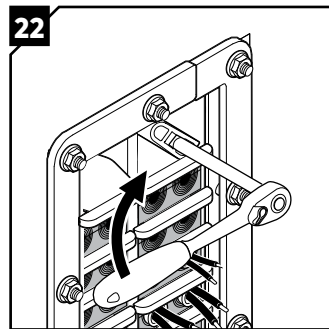

22 Use a Roxel pre-compression tool to make space for the compression units if required.

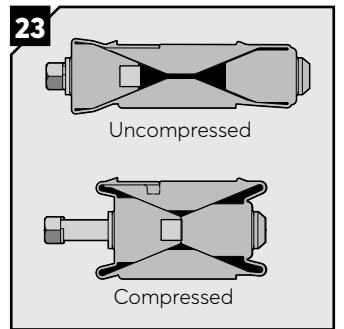

23 Ensure that the compression unit is fully uncompressed by untightening the screw of the compression unit before inserting it.

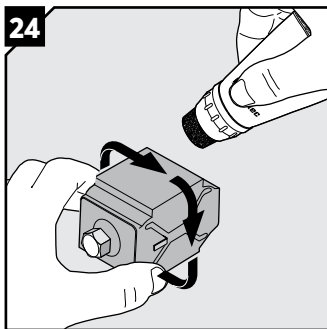

24 Lubricate the compression units on all sides with Roxel Assembly Gel Ex.

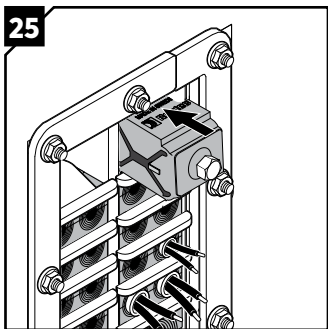

25 Insert the compression unit until stop. The compression unit can be inserted from any direction. Do not tighten the first compression unit until the second compression unit is inserted.

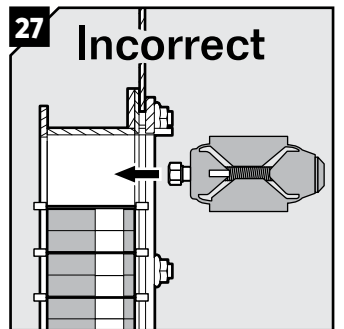
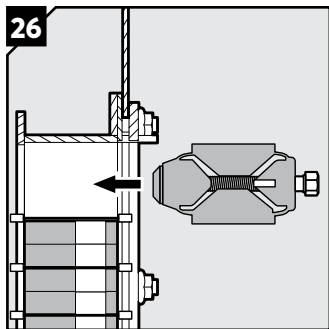

27 Do not install the compression unit with the screwhead facing the frame.

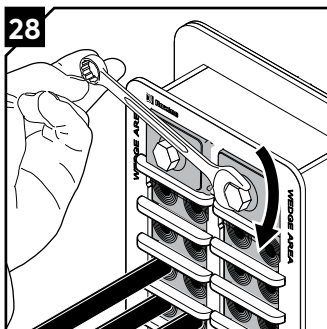

28 Tighten the screws of the compression units alternately until full stop. Do not exceed 20 Nm (15 ft.lb.).

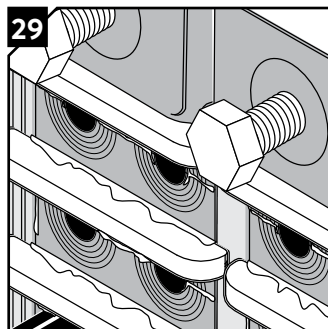

29 Visible excess Roxel Assembly Gel Ex is a sign of good compression. Make sure that all modules are placed correctly and fully inserted after compression.

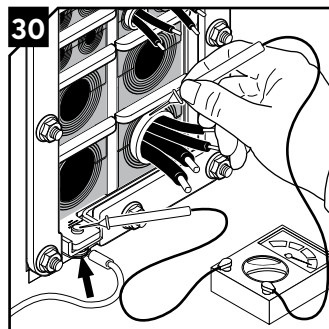

30 Verify earth continuity from each cable armor to the earth lug using a suitable instrument.

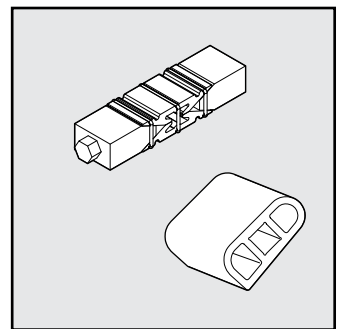

In order to further simplify installation, we provide tools for pre-compression of the modules in the frame. For more information about Roxel tools, please visit www.roxtec.com.

Preparation of metal clad and Teck cable

Finishing of interlocked and continuous welded armor.

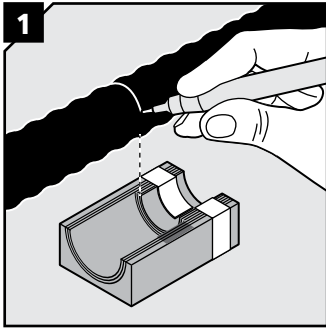

On the cable, mark where outer sheath is to be removed.

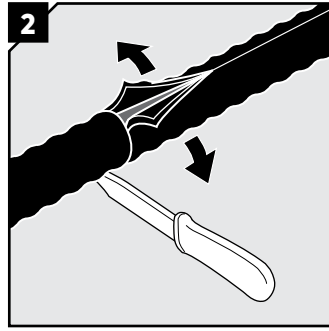

Remove the outer sheath with a tool of your choice. Make sure not to damage the cable armor. Remove any protection tape or plastics.

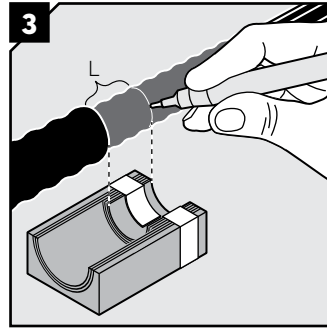

On the armor, mark with a pen the length that will match the braid section of the module half. Make sure that the armor is visible outside the module after installation.

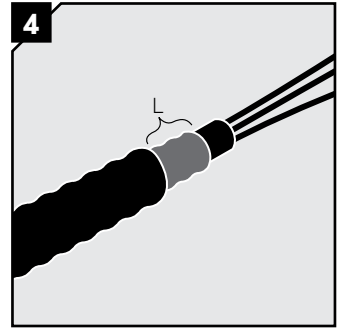

Cut the cable armor at the mark with a tool of your choice. Make sure not to damage the conductors.

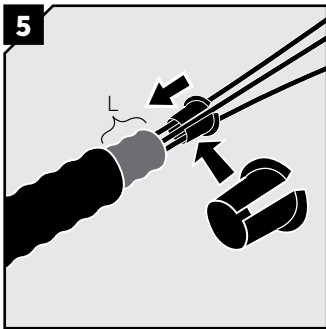

When required for inner conductor protection, fit an anti-short bushing (not supplied by Roxtec) or similar at the end cut of the cable armor.

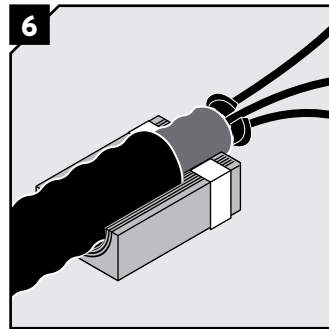

Make sure that the armor extends beyond the edge of the module and that the anti-short bushing is in place where applicable.

Preparation of SWA cable alternative 1

Finishing the end of cable armor with piece of cable sheath.

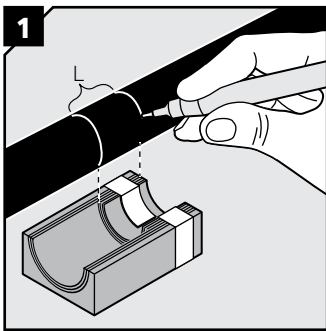

On the cable, make two marks where outer sheath is to be cut.

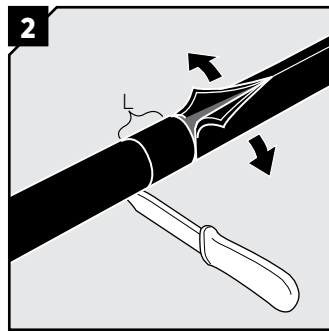

Cut the outer sheath at the two marks with a tool of your choice. Make sure not to damage the cable armor. Remove excess sheath.

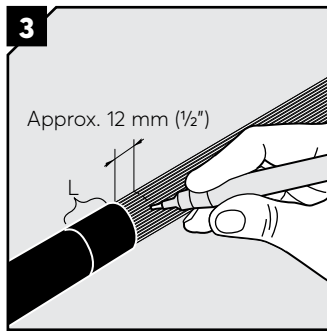

Mark where the armor is to be cut.

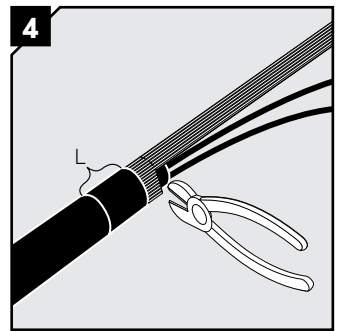

Cut the armor at the mark with a tool of your choice. Make sure not to damage the conductors.

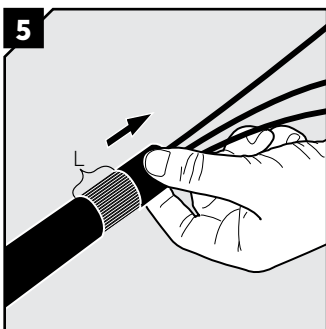

Pull the piece of cable sheath away to cover the end of the armor. The exposed armor shall accommodate both the braid and the remaining rubber of the module.

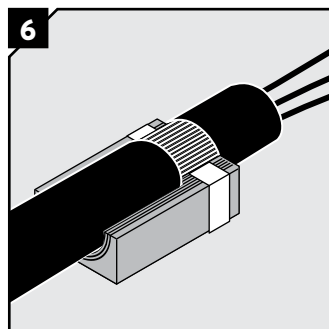

Make sure that the piece of cable sheath is completely outside the module.

See next page for alternative 2

Preparation of SWA cable alternative 2

Finishing the end of cable armor with shrink tube or tape.

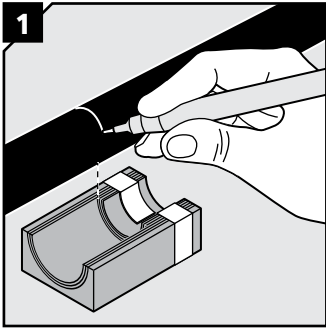

On the cable, mark where outer sheath is to be cut.

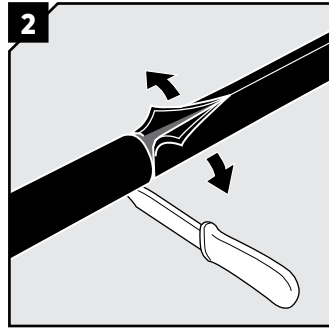

Cut the outer sheath at the mark with a tool of your choice. Make sure not to damage the cable armor.

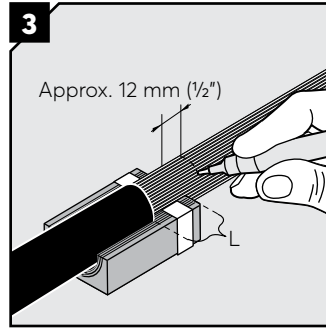

Mark where the armor is to be cut. Make sure that the armor extends beyond the module to support the shrink tube.

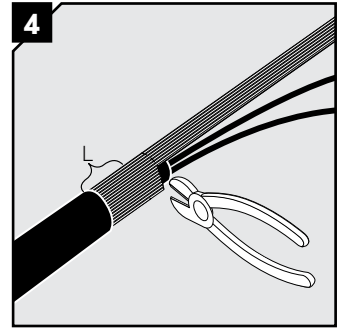

Cut the armor at the mark with a tool of your choice. Make sure not to damage the conductors.

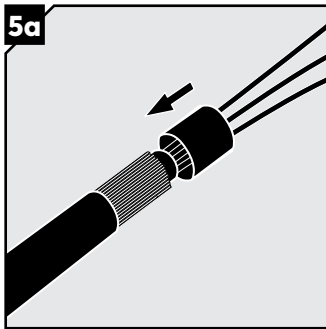

Cover the end of the armor with a piece of shrink tube.

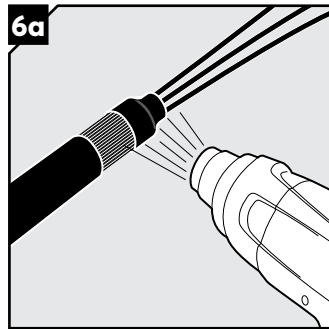

Use a hot air gun to shrink the tube.

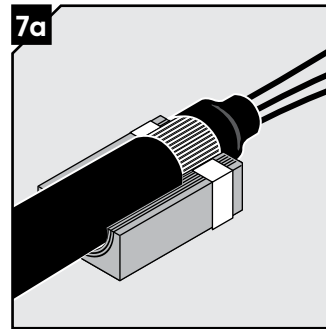

Make sure that the shrink tube is completely outside the module.

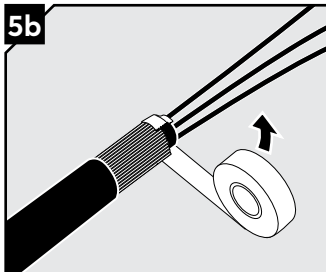

Secure the end of the armor with tape.

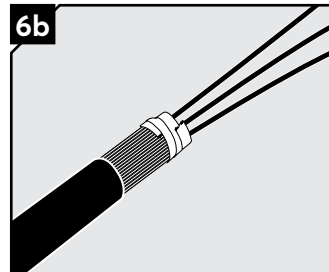

Alternative

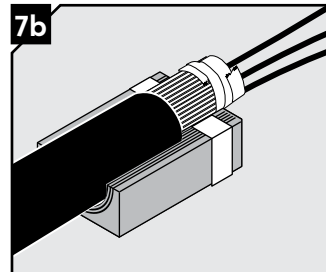

Make sure that the tape is completely outside the module.

Return to page 4 to complete the installation

Preparation of braided cable alternative 1

Finishing the end of cable armor with piece of cable sheath.

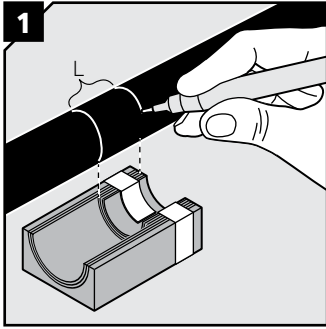

On the cable, make two marks where outer sheath is to be cut.

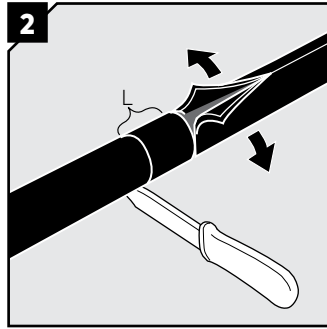

Cut the outer sheath at the two marks with a tool of your choice. Make sure not to damage the cable braid. Remove excess sheath.

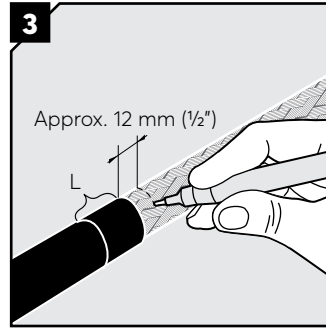

Mark where the braid is to be cut.

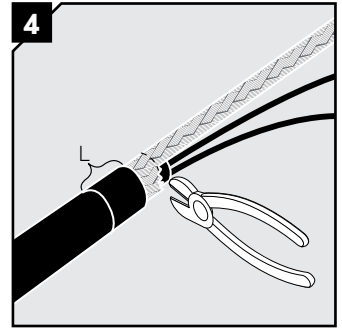

Cut the braid at the mark with a tool of your choice. Make sure not to damage the conductors.

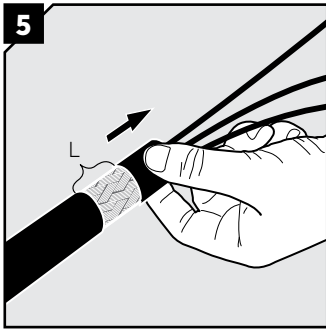

Pull the piece of cable sheath away to cover the end of the armor. The exposed armor shall accommodate both the braid and the remaining rubber of the module.

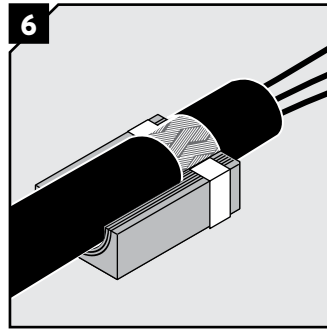

Make sure that the piece of cable sheath is completely outside the module.

See next page for alternative 2

Preparation of braided cable alternative 2

Finishing the end of cable braid with shrink tube or tape.

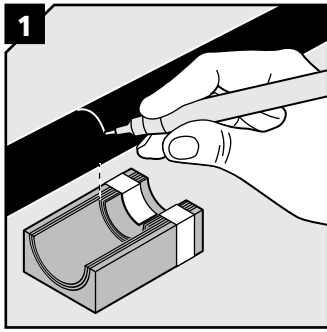

1 On the cable, mark where outer sheath is to be cut.

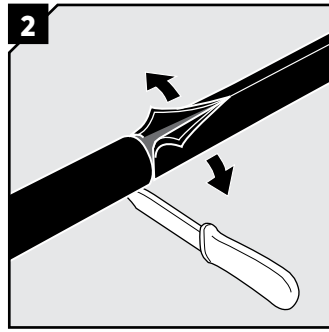

2 Cut the outer sheath at the mark with a tool of your choice. Make sure not to damage the cable braid.

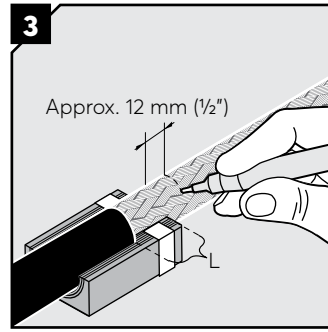

3 Mark where the braid is to be cut. Ensure that the braid extends beyond the module to support the shrink tube.

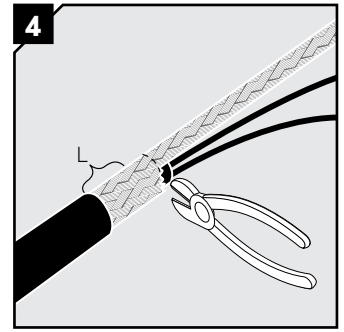

4 Cut the braid at the mark with a tool of your choice. Make sure not to damage the conductors.

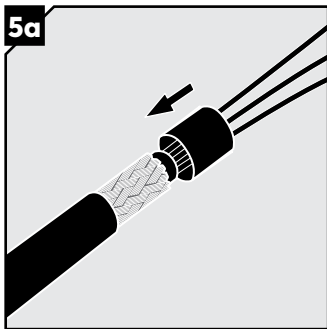

5a Cover the end of the braid with a piece of shrink tube.

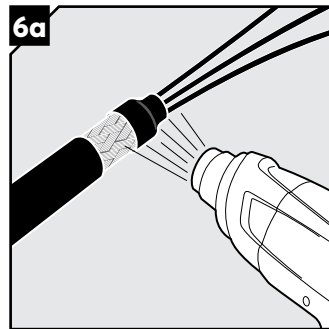

6a Use a hot air gun to shrink the tube.

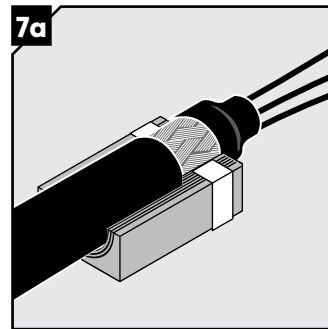

7a Make sure that the shrink tube is completely outside the module.

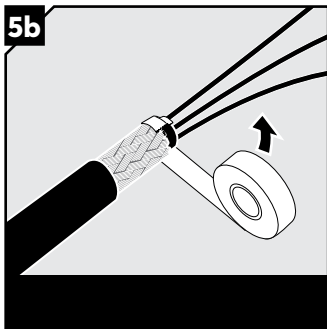

5b Secure the end of the armor with tape.

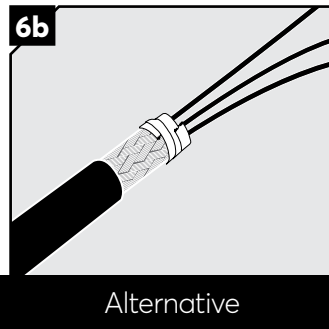

Alternative

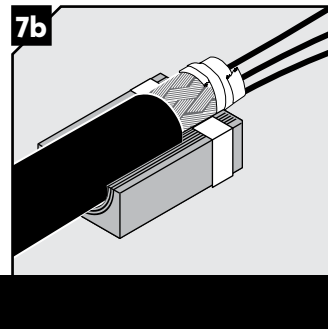

7b Make sure that the tape is completely outside the module.

Return to page 4 to complete the installation

Disassembly and reinstallation

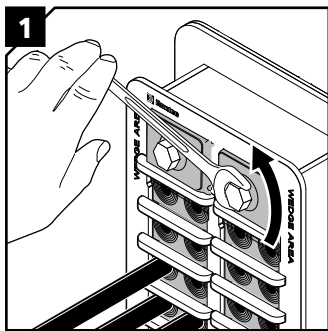

1
Untighten the screws of the compression units.

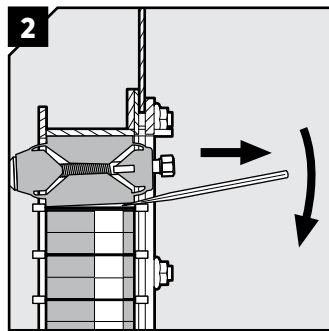

2
Insert a flat tool between the compression unit and the stayplate to simplify removal of the compression unit. Roxtec special tools are available.

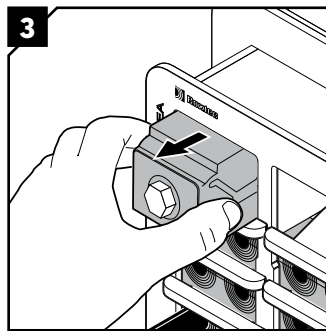

3
Remove the compression units.

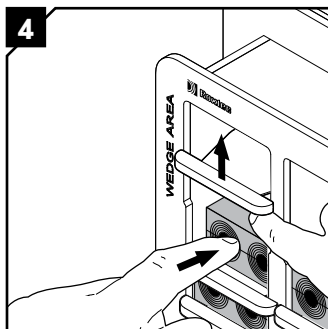

4
Lift up the stayplate and push out the upper module from the front side.

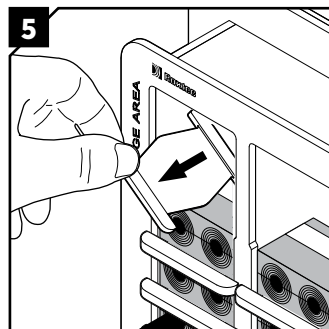

5
Remove the stayplate.

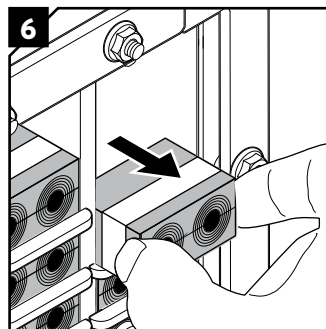

6
Continue to remove the modules. Do not damage the braids.

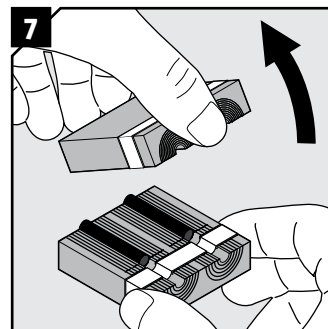

7
Separate the module halves and continue the reinstallation at step 1 on page 4.

DISCLAIMER

"The Roxtec cable entry sealing system ("the Roxtec system") is a modular-based system of sealing products consisting of different components. Each and every one of the components is necessary for the best performance of the Roxtec system. The Roxtec system has been certified to resist a number of different hazards. Any such certification, and the ability of the Roxtec system to resist such hazards, is dependent on all components that are installed as a part of the Roxtec system. Thus, the certification is not valid and does not apply unless all components installed as part of the Roxtec system are manufactured by or under license from Roxtec ("authorized manufacturer"). Roxtec gives no performance guarantee with respect to the Roxtec system, unless (I) all components installed as part of the Roxtec system are manufactured by an authorized manufacturer and (II) the purchaser is in compliance with (a), and (b), below.

(a) During storage, the Roxtec system or part thereof, shall be kept indoors in its original packaging at room temperature.

(b) Installation shall be carried out in accordance with Roxtec installation instructions in effect from time to time.

The product information provided by Roxtec does not release the purchaser of the Roxtec system, or part thereof, from the obligation to independently determine the suitability of the products for the intended process, installation and/or use.

Roxtec gives no guarantee for the Roxtec system or any part thereof and assumes no liability for any loss or damage whatsoever, whether direct, indirect, consequential, loss of profit or otherwise, occurred or caused by the Roxtec systems or installations containing components not manufactured by an authorized manufacturer and/or occurred or caused by the use of the Roxtec system in a manner or for an application other than for which the Roxtec system was designed or intended.

Roxtec expressly excludes any implied warranties of merchantability and fitness for a particular purpose and all other express or implied representations and warranties provided by statute or common law. User determines suitability of the Roxtec system for intended use and assumes all risk and liability in connection therewith. In no event shall Roxtec be liable for indirect, consequential, punitive, special, exemplary or incidental damages or losses.*



Roxtec International AB
Box 540, 371 23 Karlskrona, SWEDEN
PHONE +46 455 36 67 00, FAX +46 455 820 12
EMAIL info@roxtec.com, www.roxtec.com