

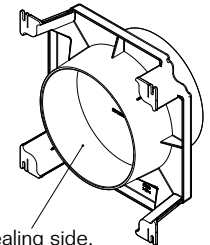

Installation instructions  
Roxtec Knock-out sleeve UG™



Sealing side.

Installation

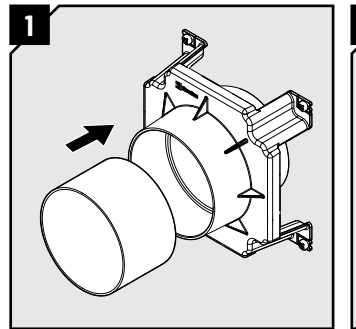

For thicker walls, use standard tubing to extend the sleeve.

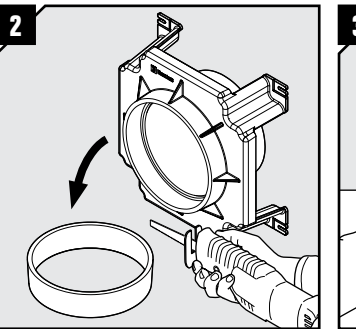

For thinner walls, cut standard Knock out sleeve to shorten the sleeve.

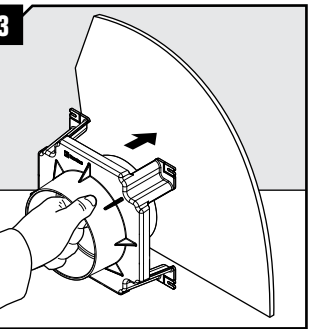

The sealing side of the Knock-out sleeve can be mounted either on the inside or the outside of the structure.

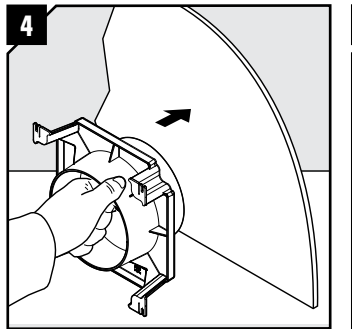

Fasten the sleeve to the mold.

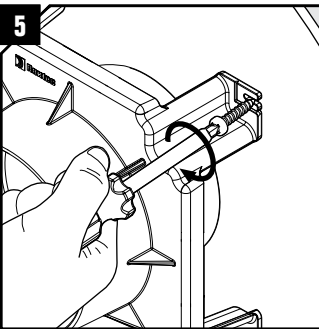

Pour concrete into the mold. Make sure to use watertight concrete.

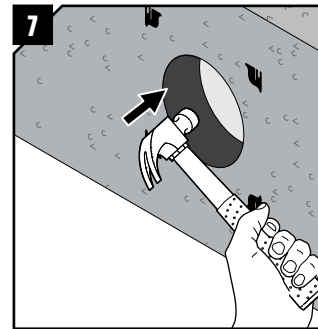
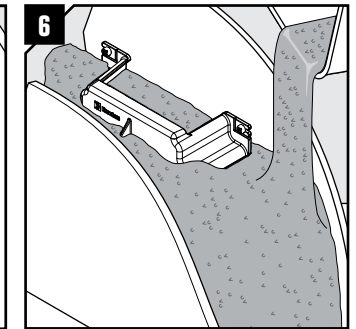

Remove the knock-out of the sleeve before inserting the seal.

**Knock-out sleeve UG™**

Sleeve	A ø (mm)	B ø (mm)
KOS 100/110 UG	102	111
KOS 125/140 UG	127	141
KOS 150/160 UG	152	161
KOS 200/200 UG	202	201

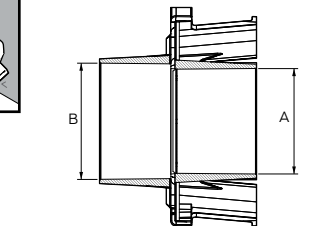

**DISCLAIMER**

"The Roxtec cable entry sealing system ("the Roxtec system") is a modular-based system of sealing products consisting of different components. Each and every one of the components is necessary for the best performance of the Roxtec system. The Roxtec system has been certified to resist a number of different hazards. Any such certification, and the ability of the Roxtec system to resist such hazards, is dependent on all components that are installed as a part of the Roxtec system. Thus, the certification is not valid and does not apply unless all components installed as part of the Roxtec system are manufactured by or under license from Roxtec ("authorized manufacturer"). Roxtec gives no performance guarantee with respect to the Roxtec system, unless (I) all components installed as part of the Roxtec system are manufactured by an authorized manufacturer and (II) the purchaser is in compliance with (a), and (b), below.  
(a) During storage, the Roxtec system or part thereof, shall be kept indoors in its original packaging at room temperature.  
(b) Installation shall be carried out in accordance with Roxtec installation instructions in effect from

time to time. The product information provided by Roxtec does not release the purchaser of the Roxtec system, or part thereof, from the obligation to independently determine the suitability of the products for the intended process, installation and/or use. Roxtec gives no guarantee for the Roxtec system or any part thereof and assumes no liability for any loss or damage whatsoever, whether direct, indirect, consequential, loss of profit or otherwise, occurred or caused by the Roxtec systems or installations containing components not manufactured by an authorized manufacturer and/or occurred or caused by the use of the Roxtec system in a manner or for an application other than for which the Roxtec system was designed or intended. Roxtec expressly excludes any implied warranties of merchantability and fitness for a particular purpose and all other express or implied representations and warranties provided by statute or common law. User determines suitability of the Roxtec system for intended use and assumes all risk and liability in connection therewith. In no event shall Roxtec be liable for indirect, consequential, punitive, special, exemplary or incidental damages or losses.