

General information

Installation and maintenance:

For European member countries of GENELEC, shall standard EN 60079-14 and EN 60079-17 be considered.

For countries members of IECEx shall standard IEC 60079-14 and IEC 60079-17 be considered.

For other countries shall applicable national regulation be considered.

The products fulfill the following standards:
EN 60079-0:2012, EN 60079-31:2009
IEC 60079-0:2011, IEC 60079-31:2008



Installation instructions
Cable transit device
Roxtec RS ES Ex

Products

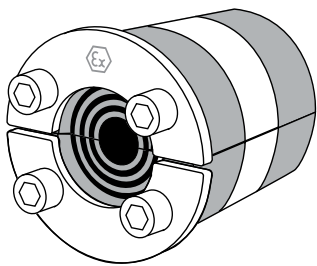

Fig. 1:
Roxtec RS ES Ex

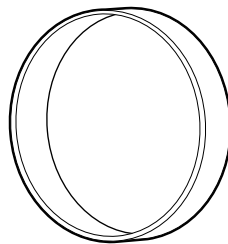

Fig. 2:
Roxtec SLRS Sleeve for welding

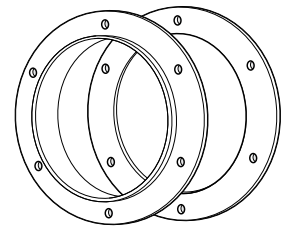

Fig. 3:
Roxtec SLFRS Sleeve and gasket for bolting

Sleeve with flange, aperture dimensions for bolted installations

Seal	Recommended aperture dimensions		Minimum clearance depth	
	Ø (mm)	Ø (in)	(mm)	(in)
RS 23 ES Ex	34	1.339	28	1.102
RS 25 ES Ex	36	1.417	28	1.102
RS 31 ES Ex	42	1.654	28	1.102
RS 43 ES Ex	54	2.126	66	2.598
RS 50 ES Ex	65	2.559	66	2.598
RS 68 ES Ex	85	3.346	66	2.598
RS 75 ES Ex	91	3.583	66	2.598
RS 100 ES Ex	116	4.567	71	2.795
RS 125 ES Ex	142	5.591	71	2.795
RS 150 ES Ex	166	6.535	73	2.874

Theoretically recommended dimensions

Installation

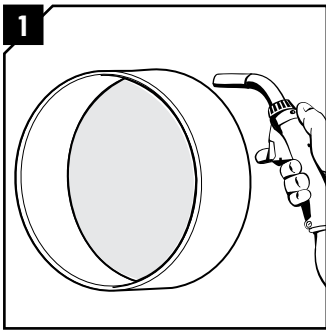

1 Weld the sleeve to the cabinet/wall. (Suggestion for welding instructions available.)

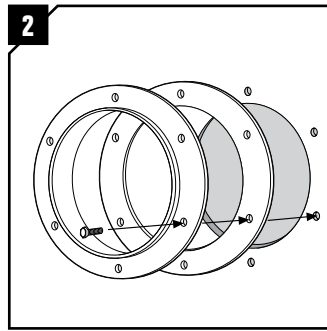

2 Sleeve for bolting. Use the sleeve as template for the drilling of the screw holes. Drill $\varnothing = 8.5$ mm.

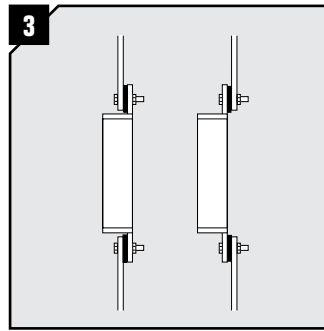

3 Attach the frame to the cabinet/wall using bolts and nuts. The rubber gasket shall be placed between frame and cabinet/wall.

4
Screw type: Hex head screw, full thread plain
Size: M8
Material: ISO 4017 or DIN 933 or SMS2165 steel 8.

Required quality.

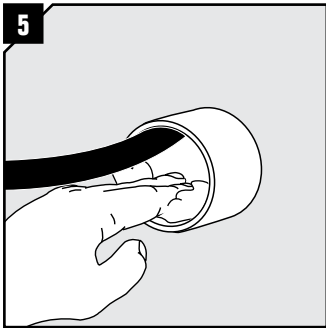

5 Clean the empty sleeve from paint, dirt etc. to secure good electrical conductivity.

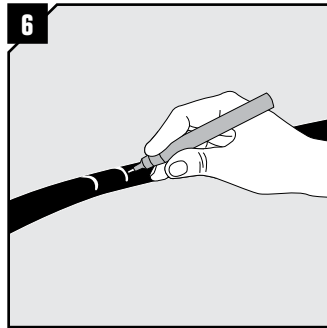

6 On the cable, mark where outer jacket is to be removed. Width depending on seal size. Please see Fig. 1.

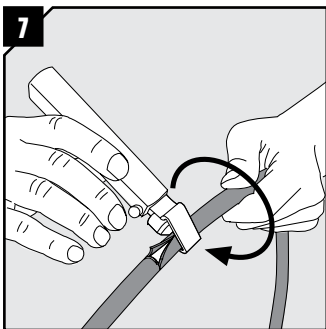
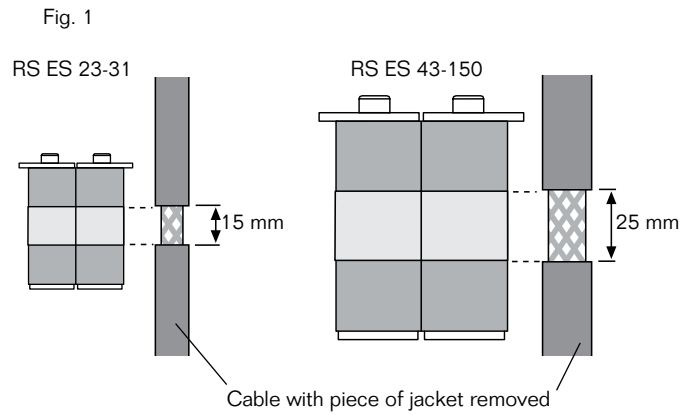

7 Cut the outer jacket with a tool of your choice. Make sure not to damage the cable screen.

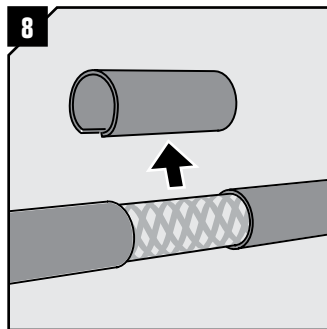

8 Remove the outer jacket and any plastic foil. Make sure cable screen is clean.

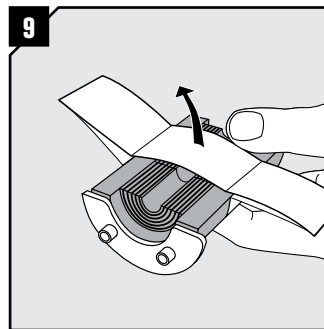

9 Remove the protection paper from the modules and fold back the tape.

Fig. 2

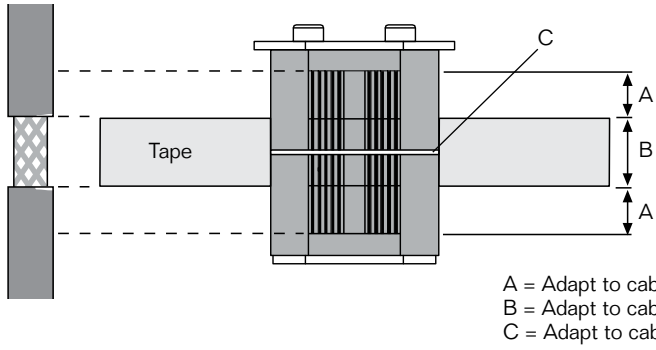
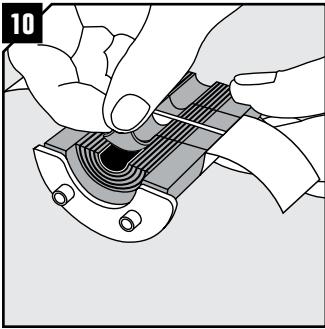
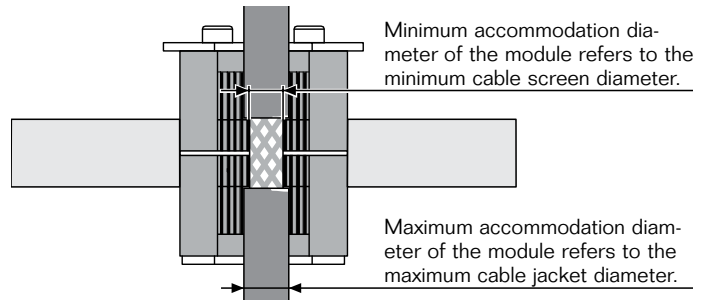
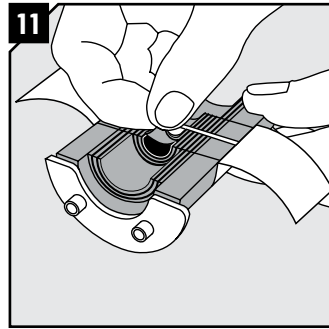

Fig. 3



10 Adapt outer layers to cable. (Fig. 2 pos. A)



11 Adapt inner layers to cable screen. (Fig. 2 pos. B)

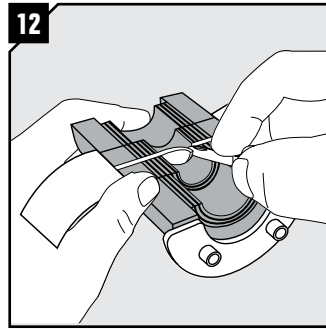

12 Adapt vertical screen to cable screen. (Fig. 2 pos. C)

Fig. 4

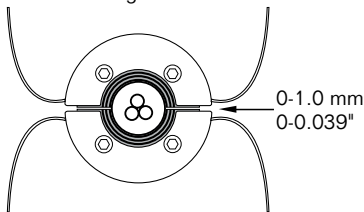

Test with a cable. Achieve a gap of 0-1.0 mm between the seal halves. If not please repeat step 10-12.

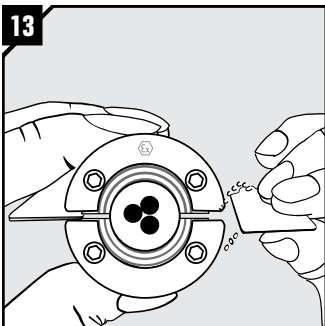

13 Measure the gap with the Ex gap gauge by holding blade one in one gap and checking the other with blade two.

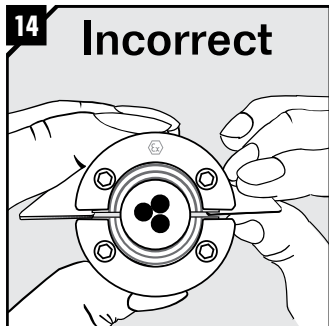

If the gap is too big, the gauge will slip in easily.

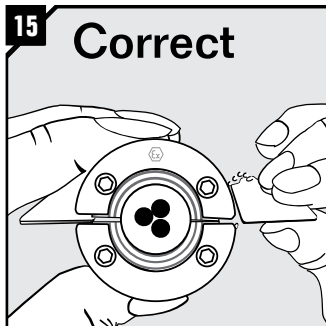

If the gap is correct, there will be no room for blade two.

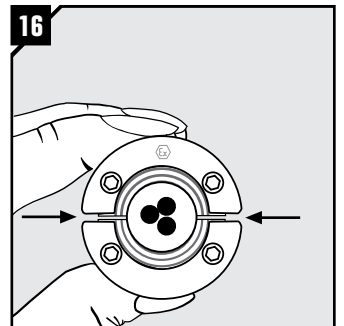

When checking without the gauge, there shall be a visual gap.

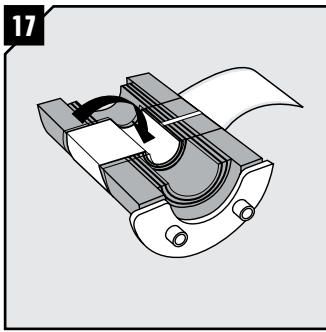

17 Fold the adhesive tape tightly inside the module half from one side along the inner layers.

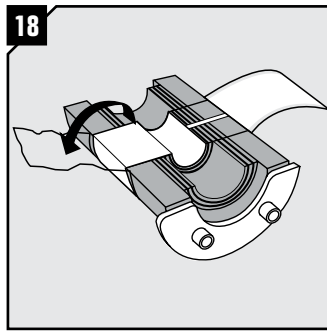

18 Lift the plastic film from the folded side.

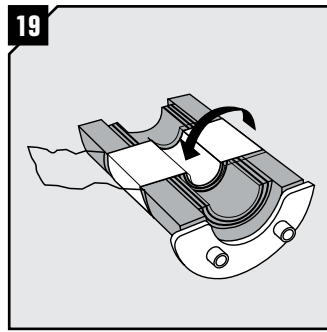

19 Fold the tape on the other side tightly inside the module half. There must be no air-pockets.

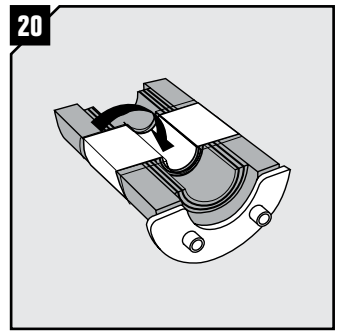

20 Fold the plastic film back inside the module half.

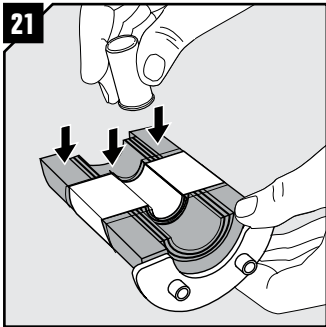

21 Lubricate the inner back rubber area of both halves of the seal sparsely with Roxtec Lubricant. Do not lubricate the film or outer back rubber area. Please see Fig. 5.

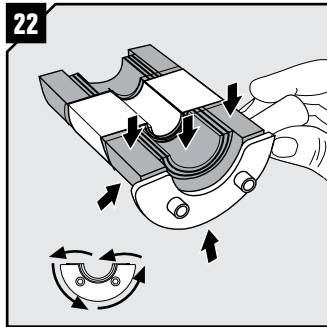

22 Lubricate the front rubber all around the seal. Please see Fig. 5.

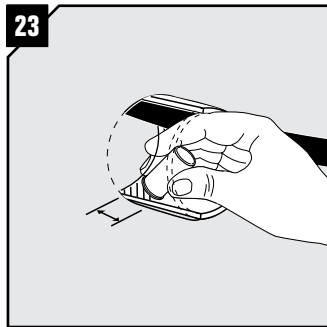

23 Lubricate inside the sleeve only where back rubber area will be located. Please see Fig. 5.

Fig. 5

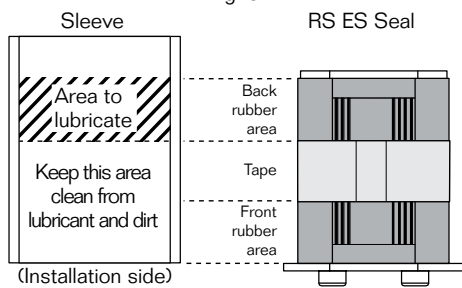

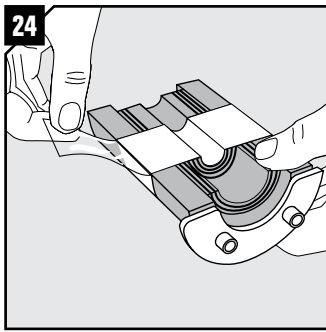

24 Remove the plastic film. Keep the tape clean.

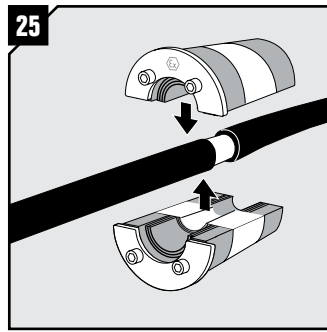

25 Assemble the seal around the cable.

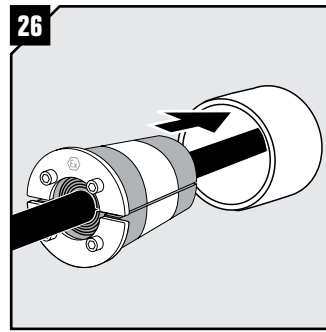

26 Install the complete seal into the sleeve.

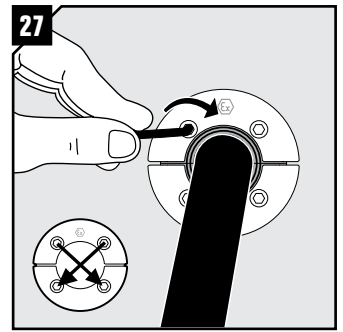

27 Tighten the screws crosswise. The seal will compress and seal the transit. Please see Fig. 6 and Fig. 7 how to indicate a tight seal and table for recommended max torque.

Fig. 6

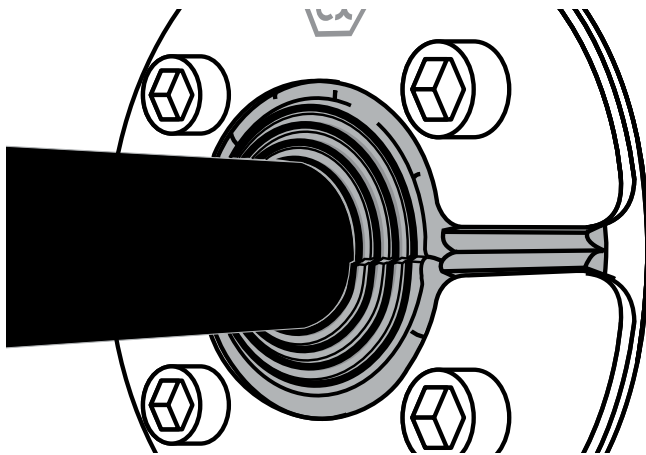
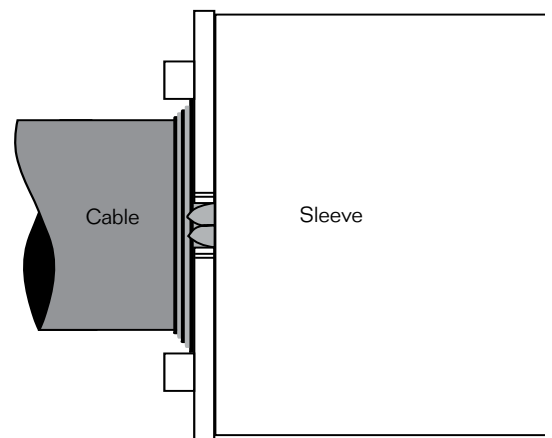

Fig. 7



The seal is compressed when rubber expands over the front fittings and the layers bulge outwards.

RS ES Ex seal

Seal	For cable/pipe	
	(mm)	(in)
RS 23 ES Ex	0+ 3.6-11	0+0.142-0.433
RS 25 ES Ex	0+ 3.6-12	0+0.142-0.472
RS 31 ES Ex	0+ 4-17	0+0.157-0.669
RS 43 ES Ex	0+ 4-23	0+0.157-0.906
RS 50 ES Ex	0+ 8-30	0+0.315-1.181
RS 68 ES Ex	0+ 26-48	0+1.024-1.890
RS 75 ES Ex	0+ 26-48	0+1.024-1.890
RS 100 ES Ex	0+ 48-70	0+1.890-2.756
RS 125 ES Ex	0+ 66-98	0+2.598-3.858
RS 100 ES Ex woc	48-70	1.890-2.756
RS 125 ES Ex woc	66-98	2.598-3.858
RS 150 ES Ex woc	93-119	3.661-4.685

woc = without core

Torque settings

Type:	Max torque* (Nm)
RS 23 ES Ex - RS 31 ES Ex	1
RS 43 ES Ex - RS 100 ES Ex	4
RS 125 ES Ex - RS 150 ES Ex	7

* The torque depends on several things, e.g cable or pipe size, amount of used lubricant, sleeve size or material in the cable sheet, etc.

Disassembly

Reverse order

Note

- An incorrectly adapted seal shall be replaced (layers shall not be reused).
- Temperature range -60 to +80 °C.
- You find the EC Type examination certificate at www.roxtec.com, or contact your local Roxtec supplier.
- Cables shall go straight through the seal.

The following conditions for safe use (apparatus certified cable transit device) and schedule of limitations (U-marked component certified cable transit device) shall be considered according to the ATEX EC Type Examination certificates and the IECEx Certificates of Conformity:

1. In order to maintain the explosion protection, the installation instructions that accompany the products shall be considered.
2. Only cable for fixed installation is permitted for the cable entry.
3. For optimum reliability wait 24 hours or longer after installation before exposing the cables/pipes to strain or pressure.
4. For cable transit device certified as Ex components and marked with the symbol U (cable transit device of type RS...W), compliance with applicable requirements not covered by sub-clauses stated below, shall be verified.

This includes mechanical test (if applicable) and test of degree of protection IP, which shall be carried out on the frame of the cable entry (excluding modules and compression unit) after it has been mounted on the enclosure of the apparatus subject to test and certification.

IEC 60079-0:2011

1, 2, 3, 4.2, 4.3, 5.2 (with respect of temperature limits), 6.1, 6.2, 7.1.1, 7.1.2.3, 7.2.1, 7.2.2, 7.5, 8.1, 8.3, 8.4, 13.1, 13.2, 13.4, 13.5, 16.3, 24, 25, 26.1, 26.2 (with respect of internal ingress protection), 26.4.1.1, 26.4.1.2, 26.4.1.2.2, 26.4.2, 26.4.4, 26.4.5.1 (with respect of internal ingress protection), 26.4.5.2, 26.7.1, 26.7.2, 26.8, 26.9, 29.1, 29.2, 29.4, 29.5, 29.9, 30.1, A.1, A.2.1, A.2.3, A.2.4.1, A.2.5, A.2.6, A.2.7, A.3.1.1, A.3.1.4, A.3.1.5, A.3.2.2, A.3.3, A.3.4 (with respect of internal ingress protection), A.4.1, A.4.2 and B.1.

EN 60079-0:2012

ZA

IEC 60079-31:2008

1, 2, 3, 4, 4.1, 5.2.1, 6.1.1 (with respect of internal ingress protection) and 7.

EN 60079-31:2009

ZA

Frame label:

RS Ex B (Bolting)

Year of
manufacture

XXXX

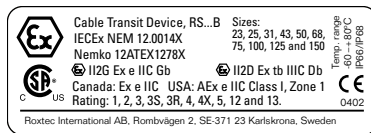

RS Ex W (Welding)

Year of
manufacture

XXXX

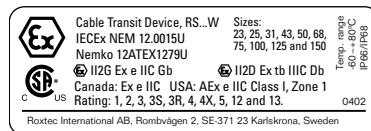

UKCA conformity marking

Can only be applied together with the ATEX and IECEx main frame label.

Applicable with Nemko 12ATEX1278X



Applicable with Nemko 12ATEX1279U



DISCLAIMER

"The Roxtec cable entry sealing system ("the Roxtec system") is a modular-based system of sealing products consisting of different components. Each and every one of the components is necessary for the best performance of the Roxtec system. The Roxtec system has been certified to resist a number of different hazards. Any such certification, and the ability of the Roxtec system to resist such hazards, is dependent on all components that are installed as a part of the Roxtec system. Thus, the certification is not valid and does not apply unless all components installed as part of the Roxtec system are manufactured by or under license from Roxtec ("authorized manufacturer"). Roxtec gives no performance guarantee with respect to the Roxtec system, unless (I) all components installed as part of the Roxtec system are manufactured by an authorized manufacturer and (II) the purchaser is in compliance with (a), and (b), below.

(a) During storage, the Roxtec system or part thereof, shall be kept indoors in its original packaging at room temperature.

(b) Installation shall be carried out in accordance with Roxtec installation instructions in effect from time to time.

The product information provided by Roxtec does not release the purchaser of the

Roxtec system, or part thereof, from the obligation to independently determine the suitability of the products for the intended process, installation and/or use. Roxtec gives no guarantee for the Roxtec system or any part thereof and assumes no liability for any loss or damage whatsoever, whether direct, indirect, consequential, loss of profit or otherwise, occurred or caused by the Roxtec systems or installations containing components not manufactured by an authorized manufacturer and/or occurred or caused by the use of the Roxtec system in a manner or for an application other than for which the Roxtec system was designed or intended.

Roxtec expressly excludes any implied warranties of merchantability and fitness for a particular purpose and all other express or implied representations and warranties provided by statute or common law. User determines suitability of the Roxtec system for intended use and assumes all risk and liability in connection therewith. In no event shall Roxtec be liable for indirect, consequential, punitive, special, exemplary or incidental damages or losses."



Roxtec International AB
Box 540, 371 23 Karlskrona, SWEDEN
PHONE +46 455 36 67 00, FAX +46 455 820 12
EMAIL info@roxtec.com, www.roxtec.com