

Safety information

Roxtec recommends that all installations are performed without facility operation. Follow national regulations and installation codes. Any action affecting the routed service should be performed according to manufacturer recommendations.

Note

- Cables/pipes shall go straight through the frame.
- For optimum reliability, wait 24 hours or longer after installation before exposing the cables/pipes to strain or pressure.
- Approvals or certificates may include amendments or limitations related to this application.
- The latest version of this and related documents are found at roxtec.com.

Installation instructions Roxtec EzEntry™ kits

Components

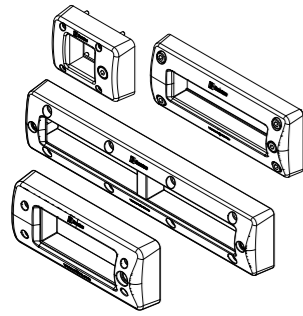

Roxtec EzEntry frames



Fasteners



Roxtec Lubricant

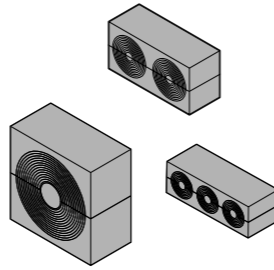

Roxtec modules

Additional information

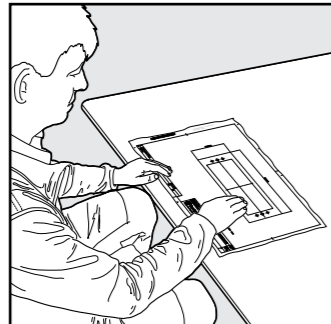

Scan QR code or visit roxtec.com for additional information such as drawings, aperture, videos, ratings and certificates.

Tools

- Allen key (not included)
- Roxtec pre-compression tool (not included)

Technical data

Name	Torque (Nm)
EZENTRY 4	3 – 5
EZENTRY 10	~ 9
EZENTRY 16	~ 9
EZENTRY 24	~ 9
EZENTRY 32	~ 9

The amount of torque needed to compress the seal depends on several things, e.g cable or pipe size, amount of used lubricant, aperture size or material in the cable sheath, etc.

Installation

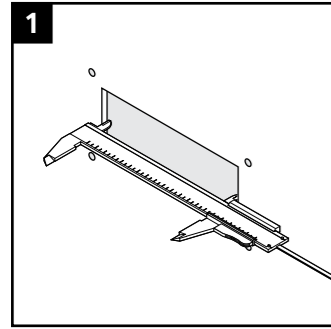

1 Make or verify an aperture.

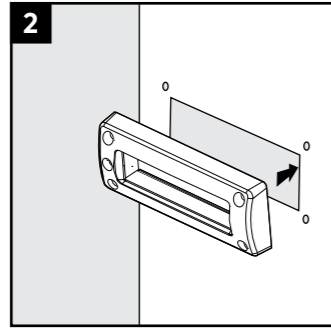

2 Insert the frame into the opening.

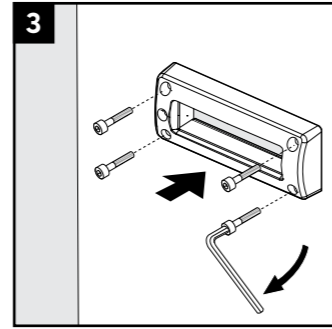

3 Tighten the screws crosswise in small steps.

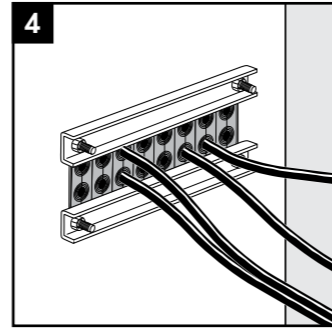

4 For EzEntry 16, use the counter flange (article no. 2CV000000016) if the thickness of the structure is 2 mm or less.

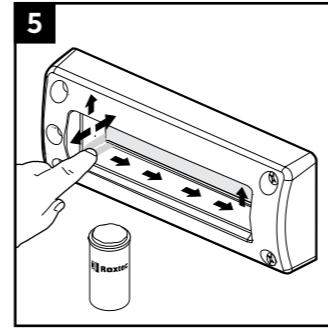

5 Clean and lubricate the sealing surfaces of the frame with Roxtec Lubricant, especially in the corners.

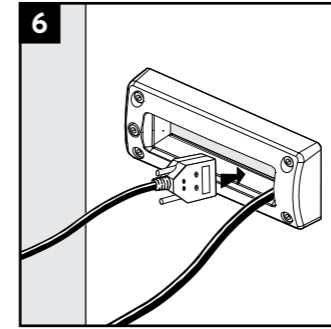

6 Insert the cables straight through the frame.

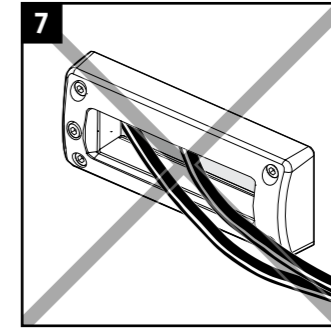

7 Angled cables are not acceptable.

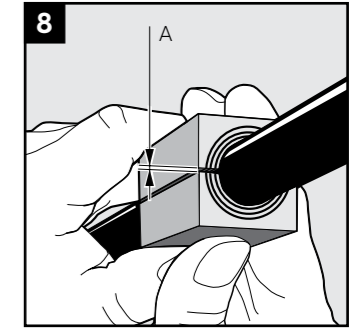

8 Achieve a gap of 0.1-1.0 mm (A) between the module halves.

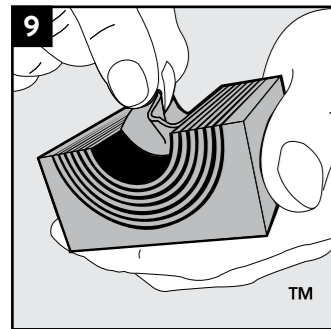

9 Adapt the modules by peeling off layers.

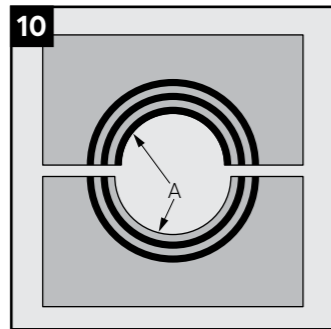

10 The number of layers may not differ (A) by more than one between the corresponding module halves.

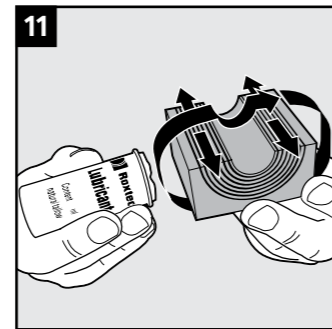

11 Lubricate the sealing surfaces of the modules.

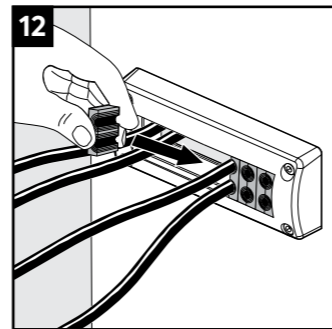

12 Insert the modules according to the packing plan.

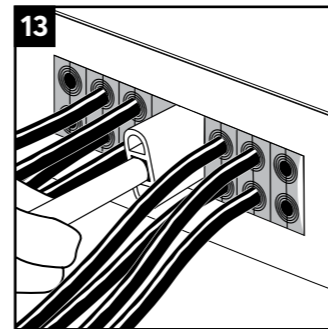

13 The use of a Roxtec pre-compression tool will simplify the installation.

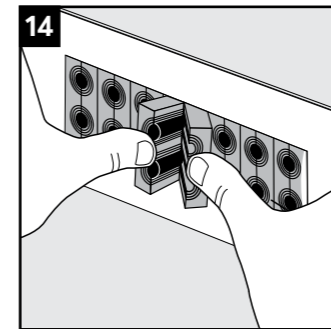

14 To simplify the insertion of the last module, angle the module halves and press them into the frame simultaneously.

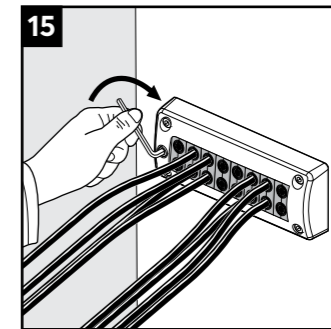

15 Tighten the screw of the compression unit to the specified torque.

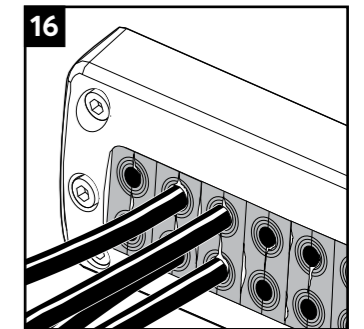

16 Excess lubricant shall be visible, and is a sign of good compression.

Disassembly and reinstallation

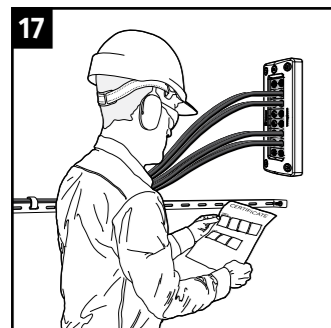

17 Check additional documentation, if applicable.

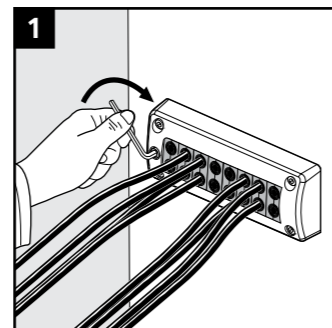

1 Untighten the screw of the integrated compression unit.

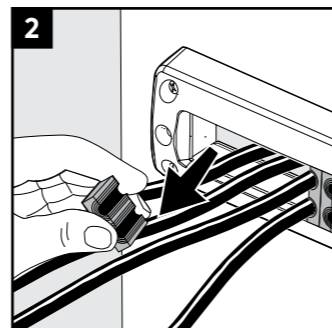

2 Remove the modules needed. Continue the reinstallation.

Disclaimer

*The Roxtec cable and pipe entry sealing system (the Roxtec system) is a modular-based system of sealing products consisting of different components. Each and every one of the components is necessary for the best performance of the Roxtec system. The Roxtec system has been certified to resist a number of different hazards. Any such certification, and the ability of the Roxtec system to resist such hazards, is dependent on all components that are installed as a part of the Roxtec system. Thus, the certification is not valid and does not apply unless all components installed as part of the Roxtec system are manufactured by or under license from Roxtec (authorized manufacturer). Roxtec gives no performance guarantee with respect to the Roxtec system, unless (i) all components installed as part of the Roxtec system are manufactured by an authorized manufacturer and (ii) the purchaser is in compliance with (a), and (b), below.
(a) During storage, the Roxtec system or part thereof, shall be kept indoors in its original packaging at room temperature.
(b) Installation shall be carried out in accordance with Roxtec installation instructions in effect from time to time.
The product information provided by Roxtec does not release the purchaser of the Roxtec system, or part thereof, from the obligation to independently

determine the suitability of the products for the intended process, installation and/or use.
Roxtec gives no guarantee for the Roxtec system or any part thereof and assumes no liability for any loss or damage whatsoever, whether direct, indirect, consequential, loss of profit or otherwise, occurred or caused by the Roxtec systems or installations containing components not manufactured by an authorized manufacturer and/or occurred or caused by the use of the Roxtec system in a manner or for an application other than for which the Roxtec system was designed or intended.
Roxtec expressly excludes any implied warranties of merchantability and fitness for a particular purpose and all other express or implied representations and warranties provided by statute or common law. User determines suitability of the Roxtec system for intended use and assumes all risk and liability in connection therewith. In no event shall Roxtec be liable for indirect, consequential, punitive, special, exemplary or incidental damages or losses. The Roxtec products are offered and sold in accordance with the conditions of the Roxtec General Terms of Sales. The latest version of the Roxtec General Terms of Sales can be found and downloaded from roxtec.com/general-terms-of-sales.



Roxtec International AB
Box 540, 371 23 Karlskrona, SWEDEN
+46 455 36 67 00, info@roxtec.com
www.roxtec.com