

Safety information

Roxtec recommends that all installations are performed without facility operation. Follow national regulations and installation codes. Any action affecting the routed service should be performed according to manufacturer recommendations.

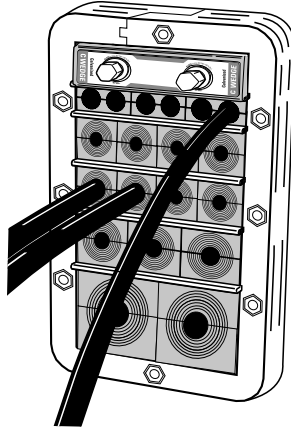

Installation instructions Roxtec C KFO 6x1

Components

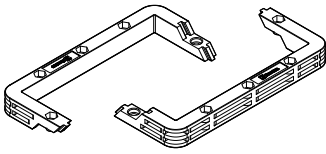

Openable Roxtec
C KFO frame

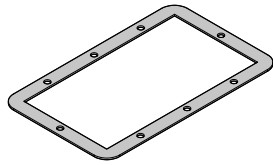

Gasket

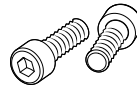

Fasteners

Tools

Not included

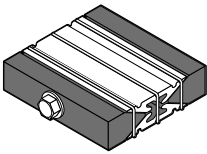

Roxtec pre-compression tool

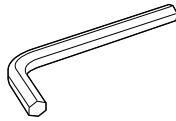

Allen key

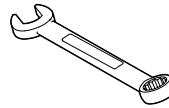

Wrench

Aperture dimensions

Maximum thickness of structure 4 mm. Measures in millimeters (mm).

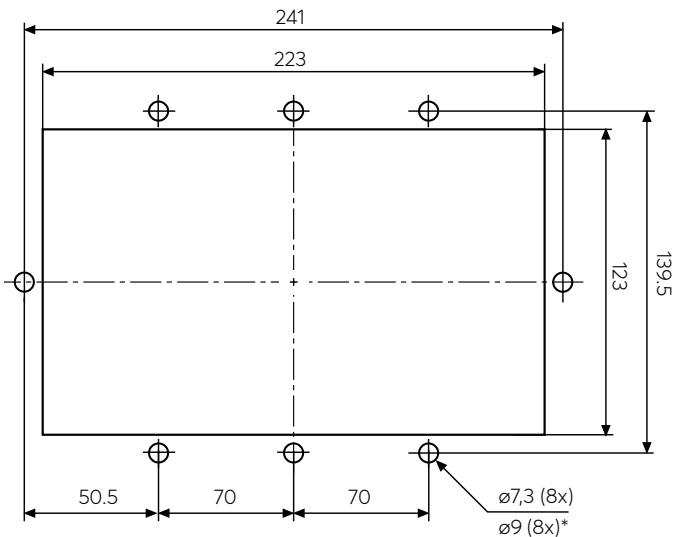

*When using counterframe in thin structures (up to 1.5 mm) the holes shall be $\varnothing 9$ mm.

Frame installation

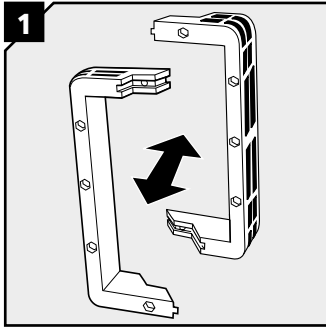

1 Divide the frame into two frame parts.

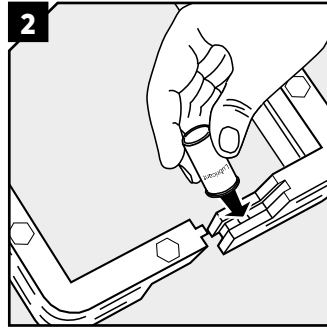

2 Lubricate all end surfaces of the frame parts with Roxeltec Lubricant.

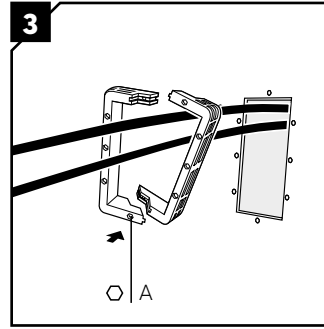

3 Reconnect the frame parts. Recessed bolt holes must point outwards, away from the structure.

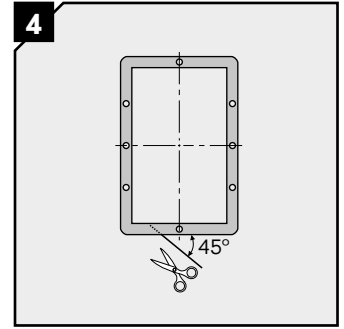

4 If cables are pre-routed, cut the gasket in a 45° angle.

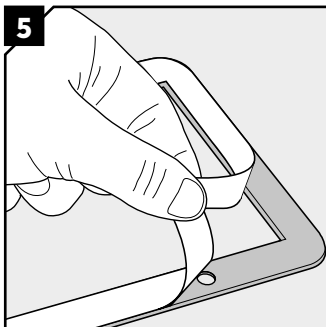

5 Remove the protection foil from the gasket.

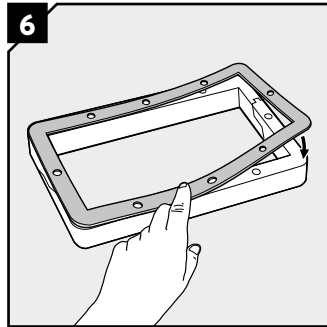

6 Apply the adhesive gasket onto the frame part that will face the structure.

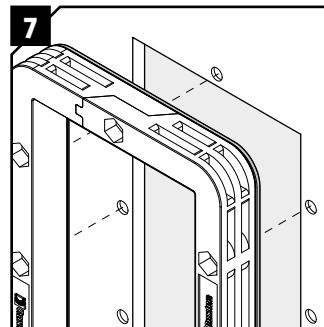

7 The recessed holes shall face outwards.

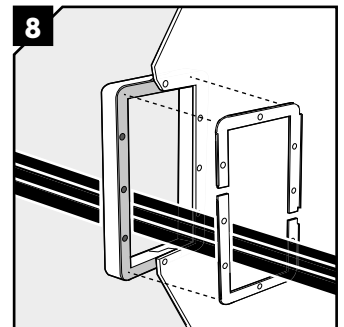

8 For thin structures of 1.5 millimeters or less a C KFO counterframe shall be used.

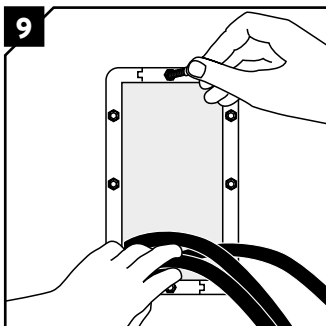

9 Attach the short sides of the frame to the structure using two of the self-tapping screws.

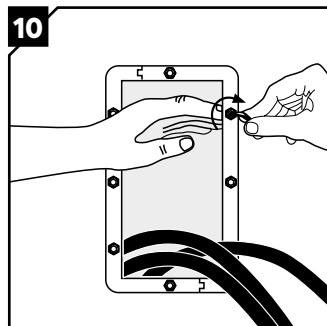

10 Insert and tighten the rest of the self-tapping screws cross-wise in small steps. Do this carefully with thin structures.

Module installation

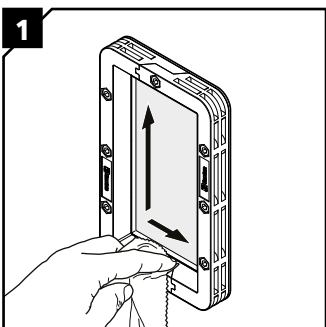

1 Clean the frame.

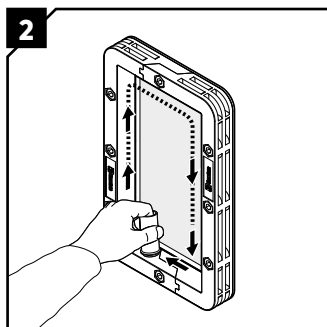

2 Lubricate the frame, especially in the corners.

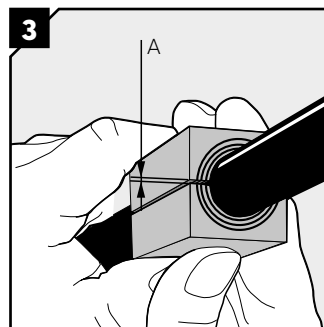

3 Achieve a gap of 0.1-1.0 mm (A) between the module halves by peeling off layers.

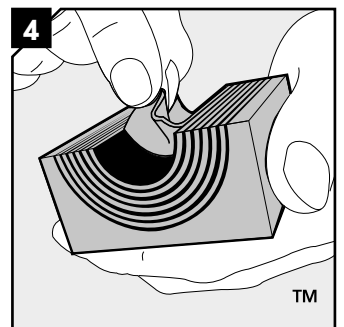

4 Peel off layers from both corresponding module halves.

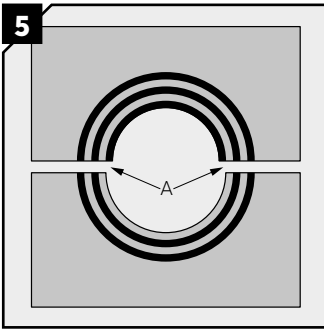

The number of layers may not differ (A) by more than one between the corresponding module halves.

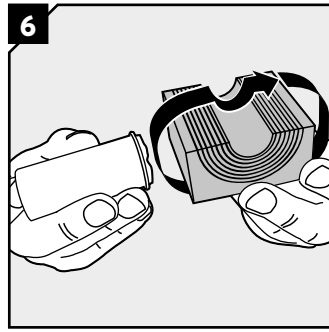

Lubricate the sealing surfaces of all modules.

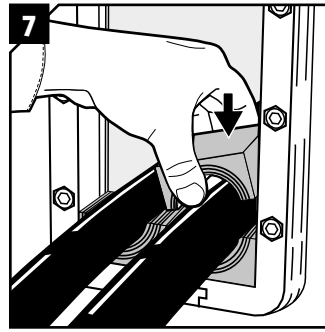

Insert the modules according to your packing plan. Start with the largest modules.

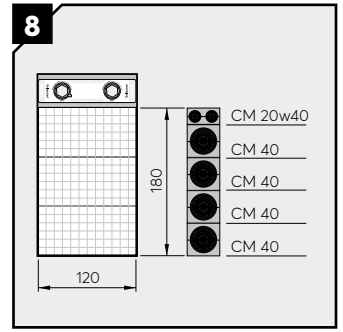

Consider the packing height of the frame. This is an example of a packing plan.



Insert a stayplate on top of every finished row of modules.

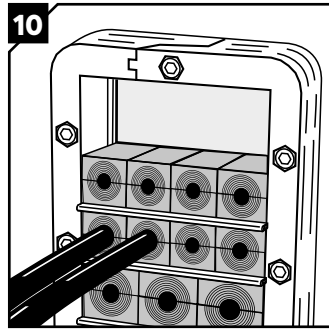

Continue to fill up the packing space of the frame until one row of modules is left.

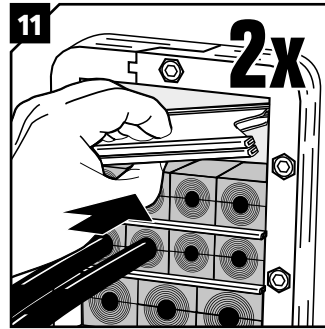

Before inserting the final row of modules, insert two stayplates.

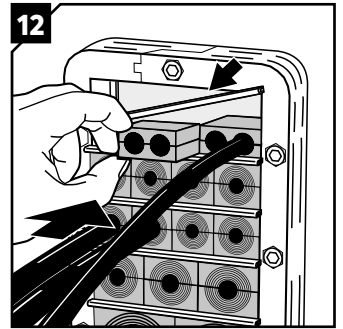

Separate the two stayplates and insert the final row of modules between the stayplates.

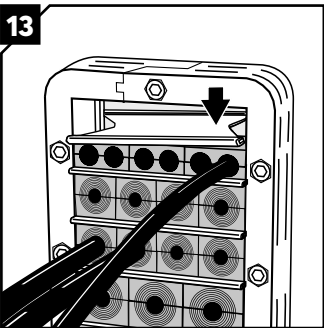

Drop the upper stayplate on top of the modules.

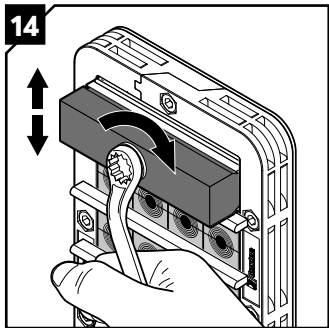

Use a Roxtec pre-compression tool to make space for the compression unit if required.

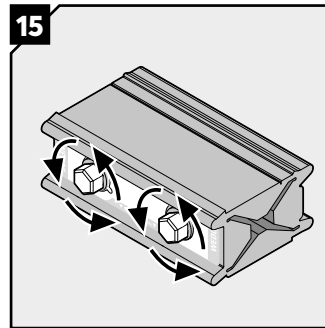

Turn the screws of the C wedge counter clock-wise to full stop.

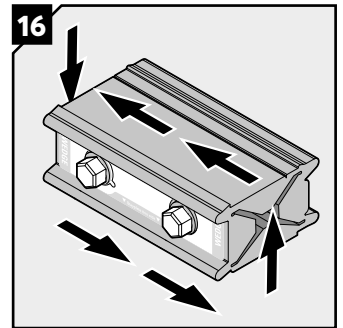

Lubricate the sealing surfaces of the C wedge.

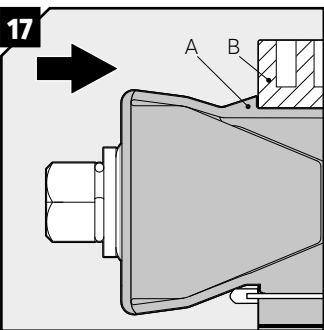

Insert the C wedge so the stop flange (A) makes contact with the frame (B).

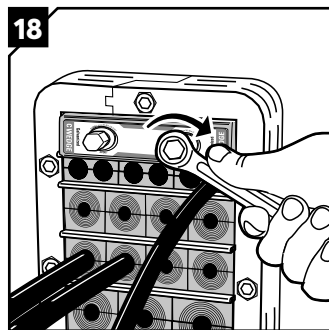

Tighten the screws alternately until full mechanical stop, approx. 20 Nm.

Disassembly

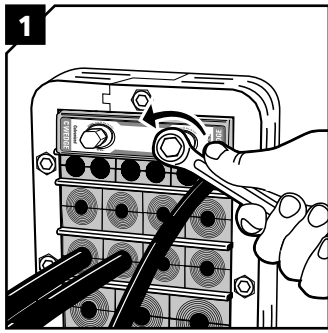

1 Untighten the screws alternately until full mechanical stop. Remove the C wedge.

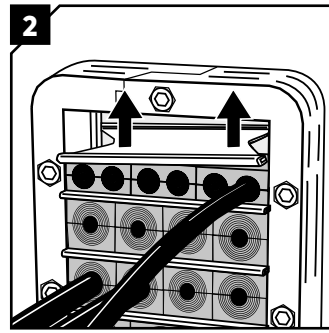

2 Lift the upper stayplate.

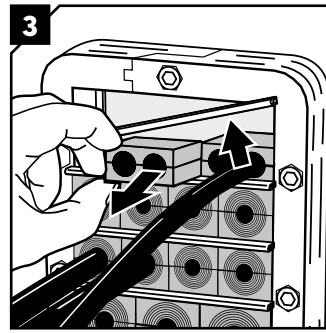

3 Remove the row of modules between the two upper stayplates.

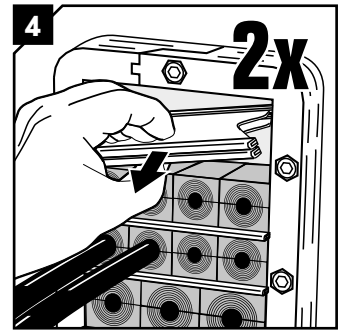

4 Remove the two upper stayplates.

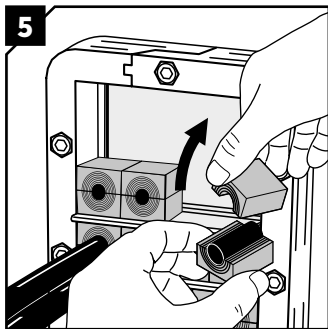

5 Remove the modules needed. Add additional cables. Adapt spare modules according to these instructions.

Note

- For optimum reliability, wait 24 hours or longer after installation before exposing the cables/pipes to strain or pressure.
- The compression unit can be placed anywhere within the frame.
- Cables/pipes shall go straight through the transit.
- This transit is to be used with CM components only.
- Approvals or certificates may include amendments or limitations related to this application.
- The latest versions of related documents are found at roxtec.com.

DISCLAIMER

"The Roxtec cable entry sealing system ("the Roxtec system") is a modular-based system of sealing products consisting of different components. Each and every one of the components is necessary for the best performance of the Roxtec system. The Roxtec system has been certified to resist a number of different hazards. Any such certification, and the ability of the Roxtec system to resist such hazards, is dependent on all components that are installed as a part of the Roxtec system. Thus, the certification is not valid and does not apply unless all components installed as part of the Roxtec system are manufactured by or under license from Roxtec ("authorized manufacturer"). Roxtec gives no performance guarantee with respect to the Roxtec system, unless (I) all components installed as part of the Roxtec system are manufactured by an authorized manufacturer and (II) the purchaser is in compliance with (a), and (b), below.
(a) During storage, the Roxtec system or part thereof, shall be kept indoors in its original packaging at room temperature.
(b) Installation shall be carried out in accordance with Roxtec installation instructions in effect from time to time.

The product information provided by Roxtec does not release the purchaser of the Roxtec system, or part thereof, from the obligation to independently determine the suitability of the products for the intended process, installation and/or use.
Roxtec gives no guarantee for the Roxtec system or any part thereof and assumes no liability for any loss or damage whatsoever, whether direct, indirect, consequential, loss of profit or otherwise, occurred or caused by the Roxtec systems or installations containing components not manufactured by an authorized manufacturer and/or occurred or caused by the use of the Roxtec system in a manner or for an application other than for which the Roxtec system was designed or intended.
Roxtec expressly excludes any implied warranties of merchantability and fitness for a particular purpose and all other express or implied representations and warranties provided by statute or common law. User determines suitability of the Roxtec system for intended use and assumes all risk and liability in connection therewith. In no event shall Roxtec be liable for indirect, consequential, punitive, special, exemplary or incidental damages or losses.*



Roxtec International AB
Box 540, 371 23 Karlskrona, SWEDEN
PHONE +46 455 36 67 00,
EMAIL info@roxtec.com, www.roxtec.com