

Installation instructions

Roxtec C KFO frame

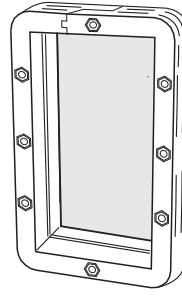

Components

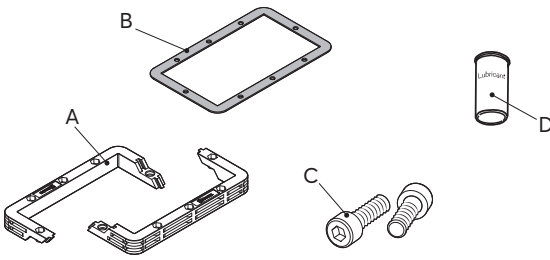

- A. Roxtec C KFO frame
- B. Gasket
- C. Fasteners
- D. Roxtec Lubricant

Additional information



Scan QR code or visit roxtec.com for additional information such as drawings, aperture, videos, ratings and certificates.

Tools

- Allen key (not included)

Installation

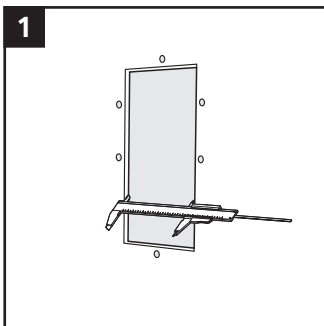

1 Make or verify an aperture.
Maximum structure thickness 4 mm.

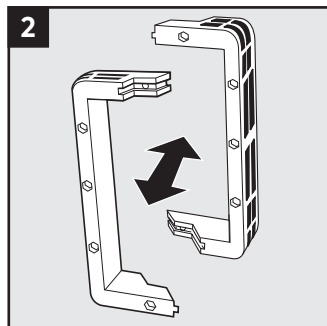

2 Divide the frame into two frame parts.

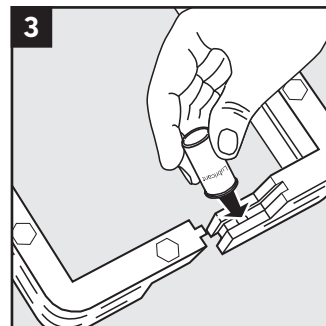

3 Lubricate all end surfaces of the frame parts with any Roxtec Lubricant.

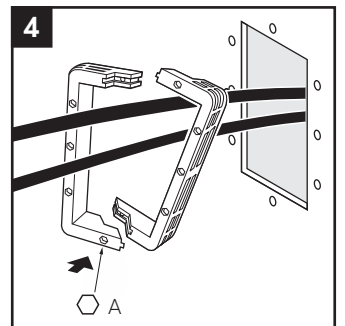

4 Reconnect the frame parts. Hexagonal bolt holes must point outwards, away from the structure.

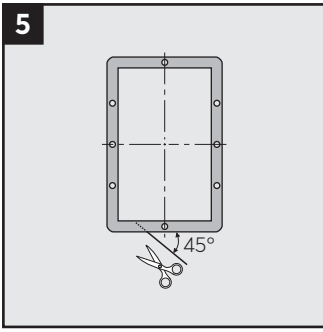

If cables are pre-routed, cut the gasket in a 45° angle.

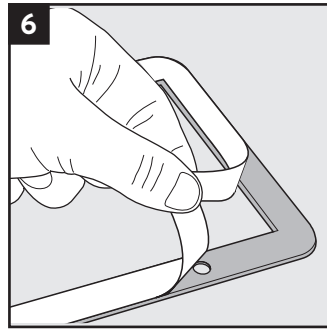

Remove the protection foil from the gasket.

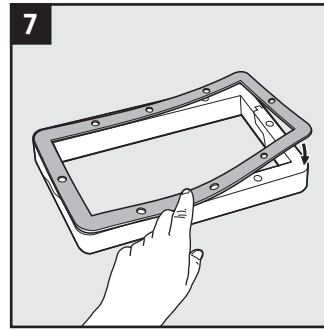

Apply the adhesive gasket onto the frame side that will face the structure. Do not apply it on the side with the hexagonal holes.

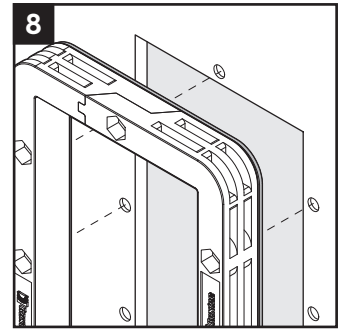

The hexagonal holes shall face outwards.

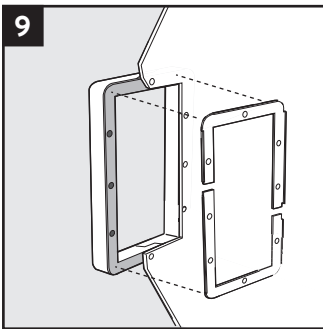

For thin structures of 1.5 millimeters or less a C KFO counterframe shall be used.

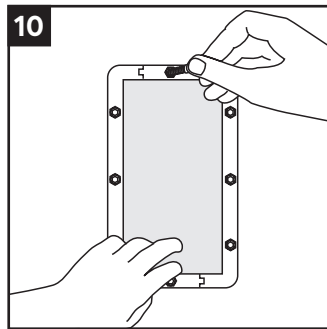

Attach the short sides of the frame to the structure using two of the self-tapping screws.

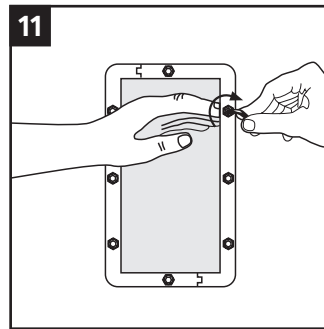

Insert and tighten the rest of the self-tapping screws cross-wise in small steps to 7 Nm. Do this carefully with thin structures.

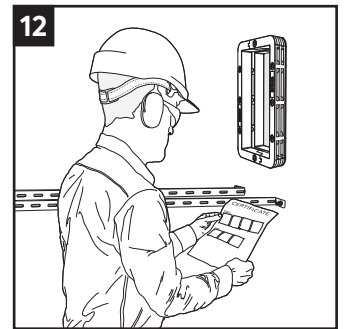

Check additional documentation, if applicable.

Note

- This transit is to be used with CM components only.
- Approvals or certificates may include amendments or limitations related to this application.
- The latest versions of related documents are found at roxtec.com.

Disclaimer

*The Roxtec cable and pipe entry sealing system ('the Roxtec system') is a modular-based system of sealing products consisting of different components. Each and every one of the components is necessary for the best performance of the Roxtec system. The Roxtec system has been certified to resist a number of different hazards. Any such certification, and the ability of the Roxtec system to resist such hazards, is dependent on all components that are installed as a part of the Roxtec system. Thus, the certification is not valid and does not apply unless all components installed as part of the Roxtec system are manufactured by or under license from Roxtec ('authorized manufacturer'). Roxtec gives no performance guarantee with respect to the Roxtec system, unless (I) all components installed as part of the Roxtec system are manufactured by an authorized manufacturer and (II) the purchaser is in compliance with (a), and (b), below.

(a) During storage, the Roxtec system or part thereof, shall be kept indoors in its original packaging at room temperature.

(b) Installation shall be carried out in accordance with Roxtec installation instructions in effect from time to time.

The product information provided by Roxtec does not release the purchaser of the Roxtec system, or part thereof, from the obligation to independently

determine the suitability of the products for the intended process, installation and/or use.

Roxtec gives no guarantee for the Roxtec system or any part thereof and assumes no liability for any loss or damage whatsoever, whether direct, indirect, consequential, loss of profit or otherwise, occurred or caused by the Roxtec systems or installations containing components not manufactured by an authorized manufacturer and/or occurred or caused by the use of the Roxtec system in a manner or for an application other than for which the Roxtec system was designed or intended.

Roxtec expressly excludes any implied warranties of merchantability and fitness for a particular purpose and all other express or implied representations and warranties provided by statute or common law. User determines suitability of the Roxtec system for intended use and assumes all risk and liability in connection therewith. In no event shall Roxtec be liable for indirect, consequential, punitive, special, exemplary or incidental damages or losses. The Roxtec products are offered and sold in accordance with the conditions of the Roxtec General Terms of Sales. The latest version of the Roxtec General Terms of Sales can be found and downloaded from roxtec.com/general-terms-of-sales.



Roxtec International AB
 Box 540, 371 23 Karlskrona, SWEDEN
 +46 455 36 67 00, info@roxtec.com
www.roxtec.com