

General information

Installation and maintenance:

For European member countries of GENELEC, shall standard EN 60079-14 and EN 60079-17 be considered.

For countries members of IECEx shall standard IEC 60079-14 and IEC 60079-17 be considered.

For other countries shall applicable national regulation be considered.

The products fulfill the following standards:

EN 60079-0:2012, EN 60079-31:2009

IEC 60079-0:2011, IEC 60079-31:2008



 **Roxtec**

Installation instructions
Cable transit device
RS Ex

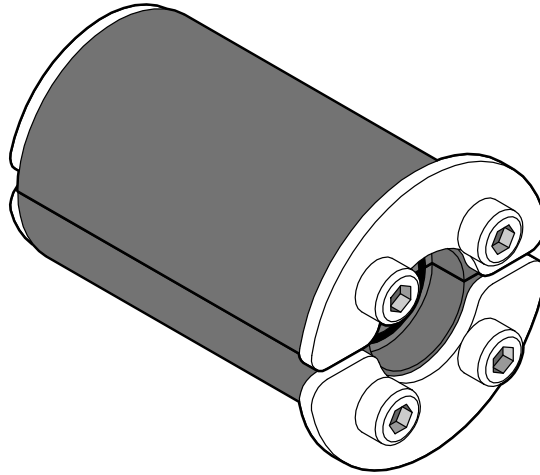

Sleeve for welding to structures (without flange)

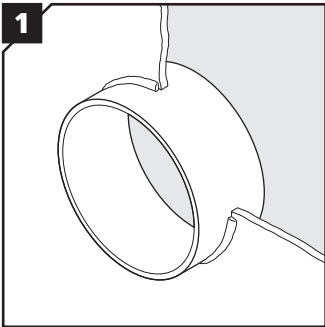

Weld the sleeve to the cabinet/wall.
Welding instructions available on
www.roxtec.com

Sleeve for bolting to structures (with flange)

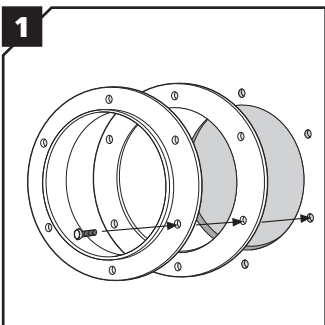

Use the sleeve as template for the drilling of the screw holes. Drill $\varnothing = 8.5$ mm.

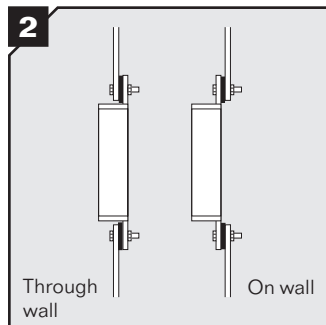

Attach the frame to the cabinet/wall using bolts and nuts. The rubber gasket shall be placed between frame and cabinet/wall.

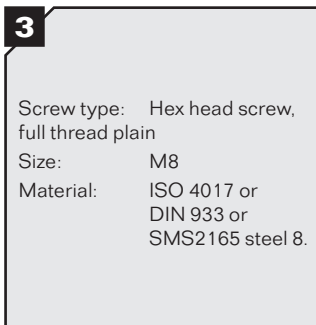

Screw type: Hex head screw,
full thread plain
Size: M8
Material: ISO 4017 or
DIN 933 or
SMS2165 steel 8.

Required quality.

Installation of RS Ex seal

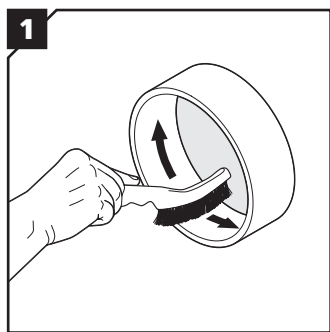

1 Clean the aperture.

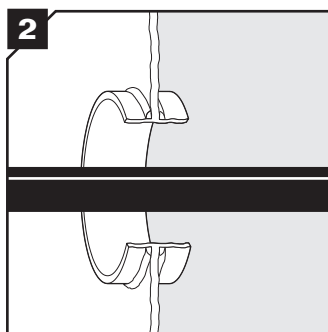

2 Feed the cable through the opening. The cable/pipe shall go straight and centered through the sleeve.

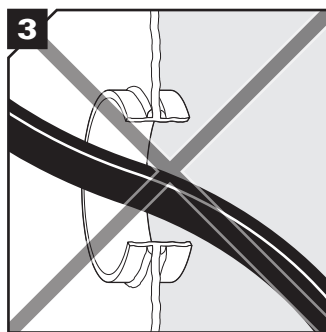

3 Not acceptable.

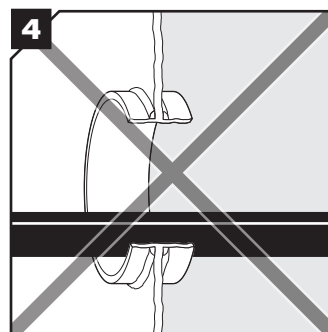

4 Not acceptable.

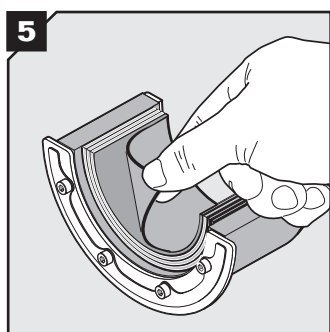

5 Adapt the seal by peeling off layers from the halves until you reach the gap seen in step 6. The number of layers may not differ by more than one between the halves.

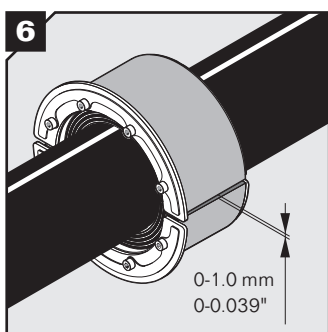

6 Achieve a 0-1.0 mm gap between the two halves when held against the cable/pipe.

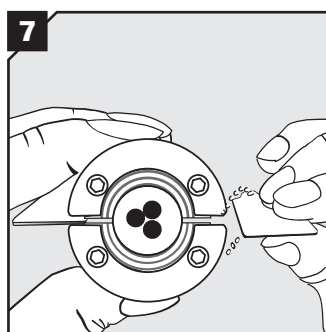

7 Measure the gap with the Ex gap gauge by holding blade one in one gap and checking the other with blade two.

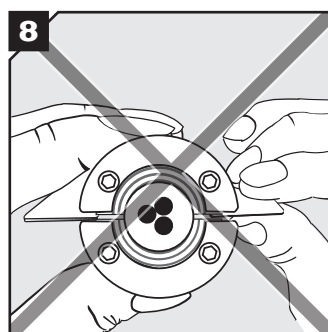

8 If the gap is too big, the gauge will slip in easily.

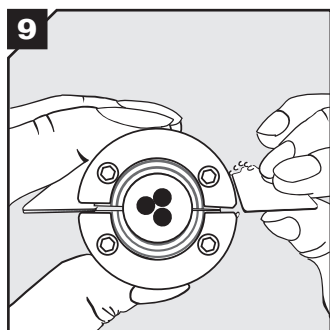

9 If the gap is correct, there will be no room for blade two.

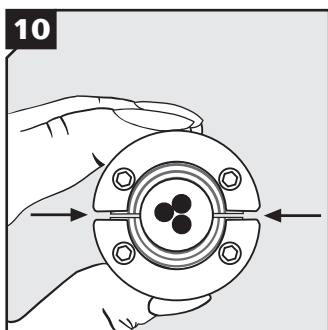

10 When checking without the gauge, there shall be a visual gap.

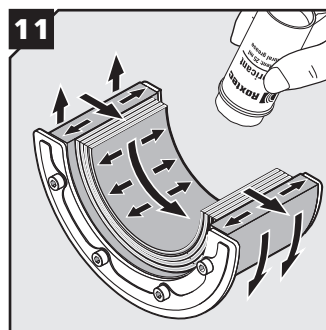

11 Lubricate the inside and the outside sealing surfaces with Rextec Lubricant.

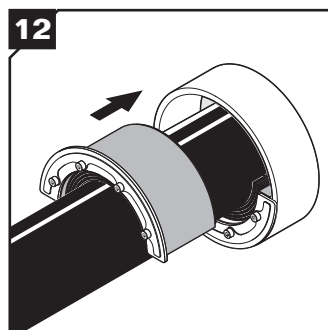

12 Insert the halves into the sleeve.

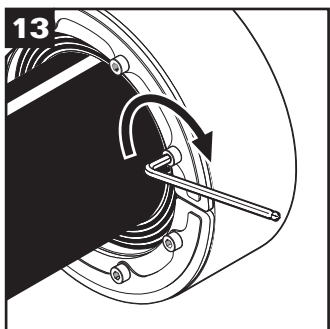

13 Tighten the bolts crosswise in small steps to firm compression.

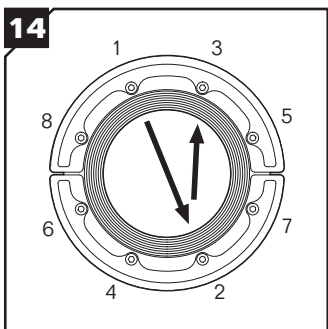

Type:	Max torque* (Nm)
RS 23 Ex - RS 31 Ex	1
RS 43 Ex - RS 100 Ex	4
RS 125 Ex - RS 150 Ex	7

* The torque depends on several things, e.g cable or pipe size, amount of used lubricant, sleeve size or material in the cable sheet, etc.

Check compression

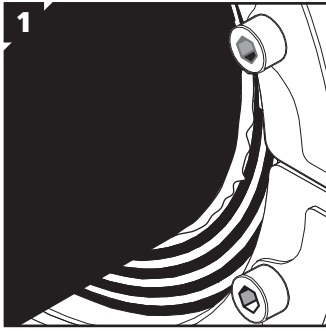

Excess lubricant shall be visible after compression.

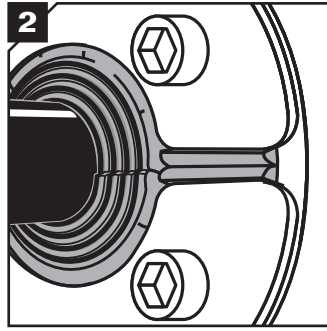

The rubber shall expand over the front fittings.

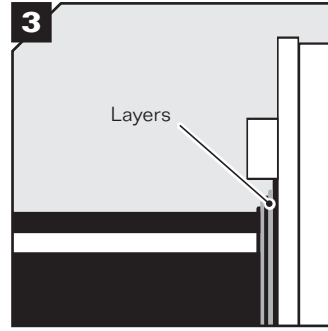

Rubber layers shall bulge outwards, if any.

Disassembly

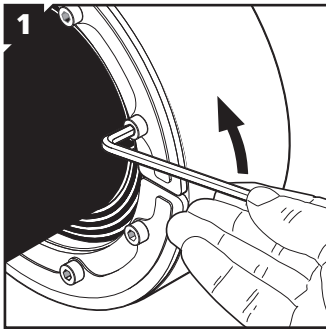

Release the compression by loosening the screws alternately.

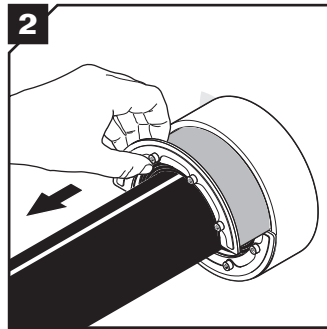

Remove the seal.

Reinstallation

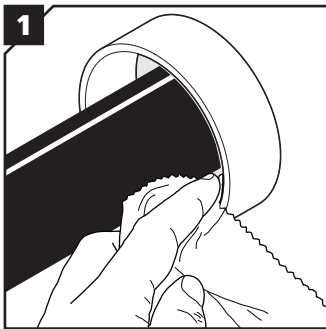

Clean the sleeve.

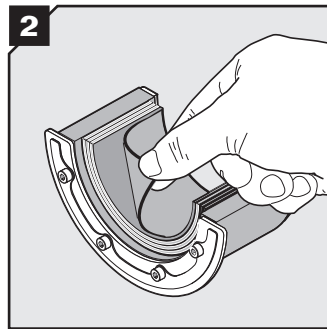

Continue the reinstallation from step 5.

Note

- An incorrectly adapted seal shall be replaced (layers shall not be reused).
- Temperature range -60 to +80 °C.
- You find the EC Type examination certificate at www.roxtec.com, or contact your local Roxtec supplier.

Sleeve with flange, aperture dimensions for bolted installations

Seal	Recommended aperture dimensions		Minimum clearance depth	
	Ø (mm)	Ø (in)	(mm)	(in)
RS 23 Ex	34	1.339	28	1.102
RS 25 Ex	36	1.417	28	1.102
RS 31 Ex	42	1.654	28	1.102
RS 43 Ex	54	2.126	66	2.598
RS 50 Ex	65	2.559	66	2.598
RS 68 Ex	85	3.346	66	2.598
RS 75 Ex	91	3.583	66	2.598
RS 100 Ex	116	4.567	71	2.795
RS 125 Ex	142	5.591	71	2.795
RS 150 Ex	166	6.535	73	2.874

Theoretically recommended dimensions

RS Ex seal

Seal	For cable/pipe	
	Ø (mm)	Ø (in)
RS 23 Ex	0+ 3.6-11	0+0.142-0.433
RS 25 Ex	0+ 3.6-12	0+0.142-0.472
RS 31 Ex	0+ 4-17	0+0.157-0.669
RS 43 Ex	0+ 4-23	0+0.157-0.906
RS 50 Ex	0+ 8-30	0+0.315-1.181
RS 68 Ex	0+ 26-48	0+1.024-1.890
RS 75 Ex	0+ 26-48	0+1.024-1.890
RS 100 Ex	0+ 48-70	0+1.890-2.756
RS 125 Ex	0+ 66-98	0+2.598-3.858
RS 100 woc Ex	48-70	1.890-2.756
RS 125 woc Ex	66-98	2.598-3.858
RS 150 woc Ex	93-119	3.661-4.685

Frame label: RS Ex B (Bolting)

Year of manufacture → XXXX

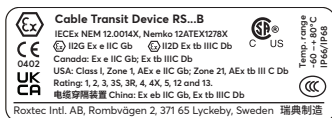

RS Ex W (Welding)

Year of manufacture → XXXX

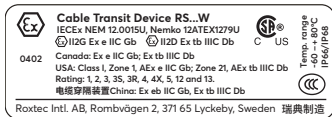

woc = without core

The following conditions for safe use (apparatus certified cable transit device) and schedule of limitations (U-marked component certified cable transit device) shall be considered according to the ATEX EC Type Examination certificates and the IECEx Certificates of Conformity:

1. In order to maintain the explosion protection, the installation instructions that accompany the products shall be considered.
2. Only cable for fixed installation is permitted for the cable entry.
3. The cable entry is ready for use not earlier than 24 h after being tightened according to the installation instructions.
4. For optimum reliability wait 24 hours or longer after installation before exposing the cables/pipes to strain or pressure.

This includes mechanical test (if applicable) and test of degree of protection IP, which shall be carried out on the frame of the cable entry (excluding modules and compression unit) after it has been mounted on the enclosure of the apparatus subject to test and certification.

IEC 60079-0:2011

1, 2, 3, 4.2, 4.3, 5.2 (with respect of temperature limits), 6.1, 6.2, 7.1.1, 7.1.2.3, 7.2.1, 7.2.2, 7.5, 8.1, 8.3, 8.4, 13.1, 13.2, 13.4, 13.5, 16.3, 24, 25, 26.1, 26.2 (with respect of internal ingress protection), 26.4.1.1, 26.4.1.2, 26.4.1.2.2, 26.4.2, 26.4.4, 26.4.5.1 (with respect of internal ingress protection), 26.4.5.2, 26.7.1, 26.7.2, 26.8, 26.9, 29.1, 29.2, 29.4, 29.5, 29.9, 30.1, A.1, A.2.1, A.2.3, A.2.4.1, A.2.5, A.2.6, A.2.7, A.3.1.1, A.3.1.4, A.3.1.5, A.3.2.2, A.3.3, A.3.4 (with respect of internal ingress protection), A.4.1, A.4.2 and B.1.

EN 60079-0:2012

ZA

IEC 60079-31:2008

1, 2, 3, 4, 4.1, 5.2.1, 6.1.1 (with respect of internal ingress protection) and 7.

EN 60079-31:2009

ZA

Disclaimer

The Roxtec cable and pipe entry sealing system (the Roxtec system) is a modular-based system of sealing products consisting of different components. Each and every one of the components is necessary for the best performance of the Roxtec system. The Roxtec system has been certified to resist a number of different hazards. Any such certification, and the ability of the Roxtec system to resist such hazards, is dependent on all components that are installed as a part of the Roxtec system. Thus, the certification is not valid and does not apply unless all components installed as part of the Roxtec system are manufactured by or under license from Roxtec (authorized manufacturer). Roxtec gives no performance guarantee with respect to the Roxtec system, unless (I) all components installed as part of the Roxtec system are manufactured by an authorized manufacturer and (II) the purchaser is in compliance with (a), and (b), below.
 (a) During storage, the Roxtec system or part thereof, shall be kept indoors in its original packaging at room temperature.
 (b) Installation shall be carried out in accordance with Roxtec installation instructions in effect from time to time.
 The product information provided by Roxtec does not release the purchaser of the Roxtec system, or part thereof, from the obligation to independently determine the suitability of the products for the intended process, installation and/or use.

Roxtec gives no guarantee for the Roxtec system or any part thereof and assumes no liability for any loss or damage whatsoever, whether direct, indirect, consequential, loss of profit or otherwise, occurred or caused by the Roxtec systems or installations containing components not manufactured by an authorized manufacturer and/or occurred or caused by the use of the Roxtec system in a manner or for an application other than for which the Roxtec system was designed or intended.

Roxtec expressly excludes any implied warranties of merchantability and fitness for a particular purpose and all other express or implied representations and warranties provided by statute or common law. User determines suitability of the Roxtec system for intended use and assumes all risk and liability in connection therewith. In no event shall Roxtec be liable for indirect, consequential, punitive, special, exemplary or incidental damages or losses.

The Roxtec products are offered and sold in accordance with the conditions of the Roxtec General Terms of Sales. The latest version of the Roxtec General Terms of Sales can be found and downloaded from roxtec.com/general-terms-of-sales.



Roxtec International AB
 Box 540, 371 23 Karlskrona, SWEDEN
 PHONE +46 455 36 67 00, FAX +46 455 820 12
 EMAIL info@roxtec.com, www.roxtec.com