

General information

Installation and maintenance: For European member countries of GENELEC shall standard EN 60079-14 and EN 60079-17 be considered. For countries members of IECEx shall standard IEC 60079-14 and IEC 60079-17 be considered. For other countries shall applicable national regulations be considered.

The products fulfill the following standards:
EN 60079-0:2012, EN 60079-7:2007, EN 60079-31:2009
IEC 60079-0:2011, EN 60079-7:2006, IEC 60079-31:2008



Installation instructions Cable Transit Device R Ex and RO Ex type

Aperture dimensions

Sleeve for welding

Sleeve size	Recommended aperture dimensions	
	Ø (mm)	Ø (in)
70	85	3.346
75	91	3.583
100	116	4.567
125	142	5.591
127	142	5.591
150	166	6.535
200	216	8.504

Aperture dimensions

Sleeve for bolting

Sleeve size	Recommended aperture dimensions	
	Ø (mm)	Ø (in)
70	87	3.425
75	93	3.661
100	118	4.646
125	144	5.669
127	144	5.669
150	168	6.614
200	218	8.583

Installation

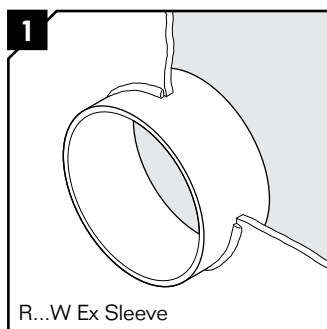

Sleeve for welding. Weld the sleeve to the cabinet/wall. Welding instructions available on www.roxtec.com

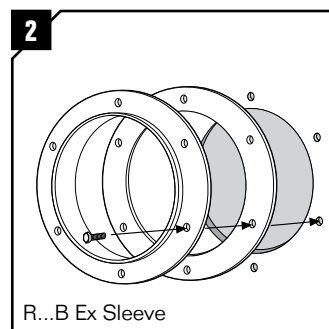

Sleeve for bolting. Use the sleeve as template for the drilling of the screw holes. Drill Ø = 8.5 mm.

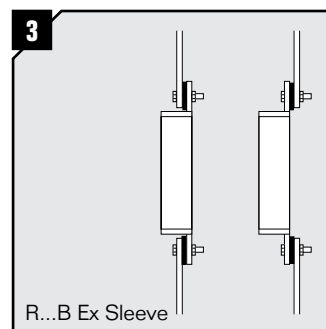

Attach the frame to the cabinet/wall using bolts and nuts. The rubber gasket shall be placed between frame and cabinet/wall.

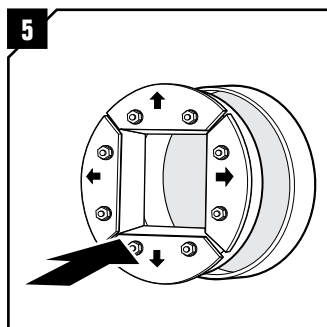
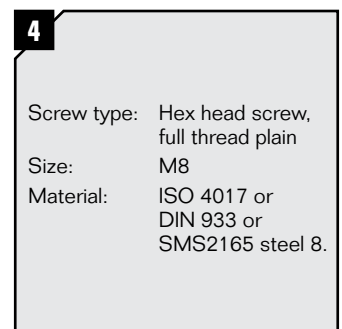

Lubricate the outside of the R frame sparsely. Insert the frame into the hole. Push the front fittings of the frame to the sides.

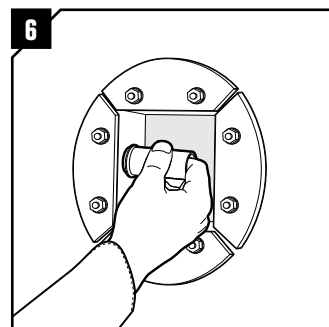

Lubricate the inside of the R frame. Make sure to lubricate into the corners.

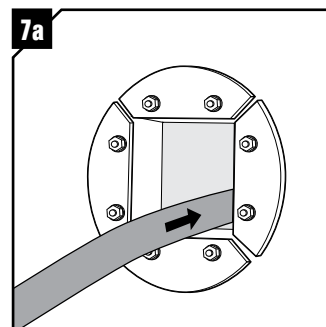

Pull the cables through.

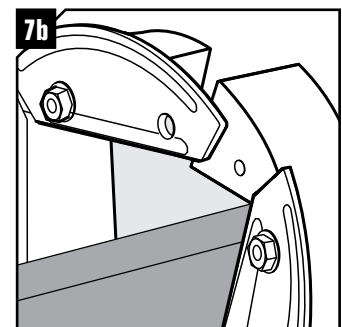

For pre-routed cables, use the RO (openable) frame. Disassemble and open the RO frame and wrap it around the cables.

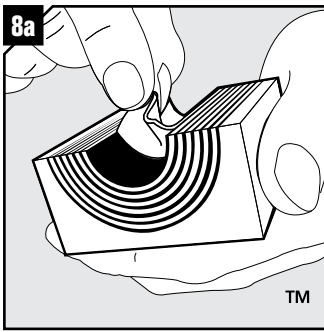

Adapt the modules which are to hold cables or pipes by peeling off layers. The halves may not differ by more than one layer.

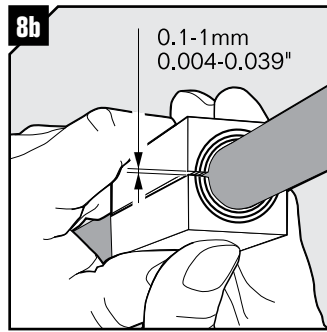

Try to achieve a 0.1–1.0 mm gap between the two halves when held against the cable/pipe.

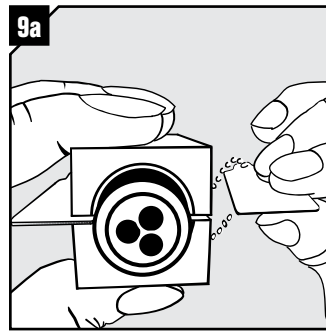

Measure the gap with the Ex Gap Gauge by holding blade one in one gap and checking the other with blade two.

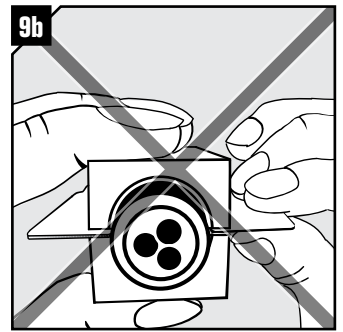

If the gap is too big, the gauge will slip in easily.

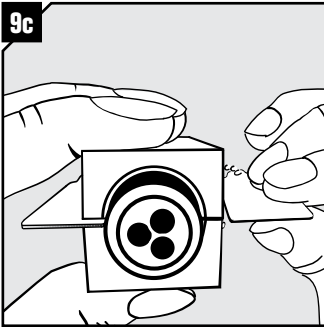

If the gap is correct, there will be no room for blade two.

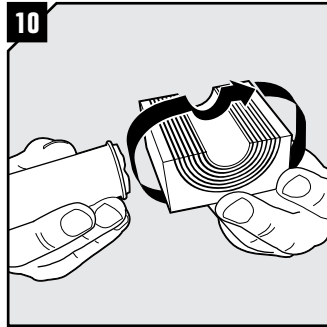

Lubricate the modules thoroughly, on both inside and outside faces.

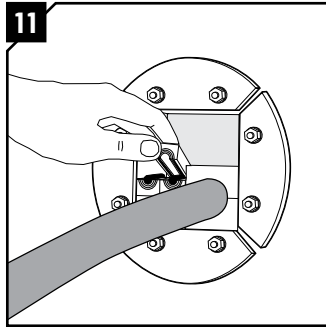

Insert the modules according to your packing plan.

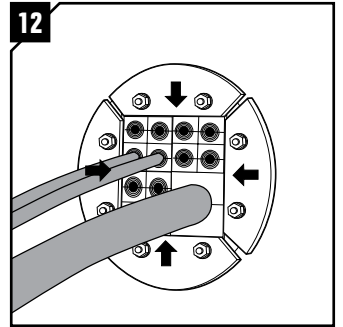

Push the front fittings back towards the center.

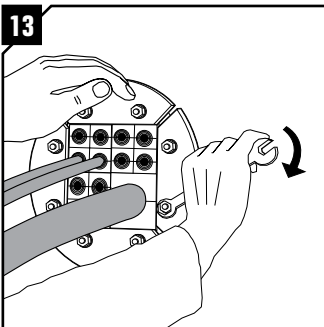

Tighten the nuts crosswise until the frame is sealed.

Torque settings

Nuts size	Rec torque (Nm)
M6	7
M8	10

Disassembly

Reverse order.

Note

- An incorrectly adapted module shall be replaced (layers shall not be reused).
- Temperature range -60 to +80 °C.
- Permitted Roxtec modules: RM Ex type.
- You find EC Type examination certificate on www.roxtec.com, or contact your local Roxtec supplier.

Standard adaptable modules Ex

Module	Number of cables/pipes	For cable/pipe diameter	
		a-b (mm)	a-b (in)
with core			
RM 15 Ex	1	0+3.0-11.0	0+ 0.118-0.433
RM 15w40 Ex	3	0+3.5-10.5	0+ 0.138-0.413
RM 20 Ex	1	0+4.0-14.5	0+ 0.157-0.571
RM 20w40 Ex	2	0+3.5-16.5	0+ 0.138-0.650
RM 30 Ex	1	0+10.0-25.0	0+ 0.394-0.984
RM 40 Ex	1	0+21.5-34.5	0+ 0.846-1.358
RM 40 10-32 Ex	1	0+9.5-32.5	0+ 0.374-1.280
RM 60 Ex	1	0+28.0-54.0	0+ 1.102-2.126
RM 60 24-54 Ex	1	0+24.0-54.0	0+ 0.945-2.126
RM 80 Ex	1	0+48.0-71.0	0+ 1.890-2.795
RM 90 Ex	1	0+48.0-71.0	0+ 1.890-2.795
RM 120 Ex	1	0+67.5-99.0	0+ 2.657-3.898
without core			
RM 60 Ex woc	1	28.0-54.0	1.102-2.216
RM 80 Ex woc	1	48.0-71.0	1.890-2.795
RM 90 Ex woc	1	48.0-71.0	1.890-2.795
RM 120 Ex woc	1	67.5-99.0	2.657-3.898

Solid compensation modules Ex

Module
RM 5/0x24 Ex
RM 10/0x12 Ex
RM 15/0 Ex
RM 20/0 Ex
RM 30/0 Ex
RM 40/0 Ex
RM 60/0 Ex

Single diameter modules Ex

Module
RM 20/14 Ex
RM 20/15 Ex
RM 20/16 Ex
RM 30/24 Ex
RM 30/26 Ex
RM 40/34 Ex
RM 40/36 Ex
RM 60/52 Ex
RM 60/54 Ex

Frame label:

Year of manufacture

XXX

R...B Ex (Bolting)

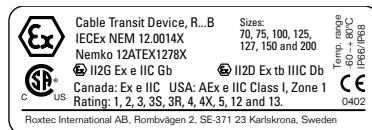

R...W Ex (Welding)

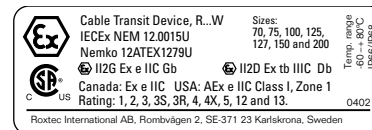

RO...B Ex (Bolting)

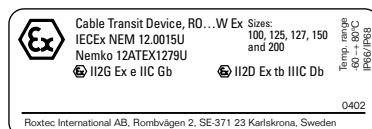

RO...W Ex (Welding)

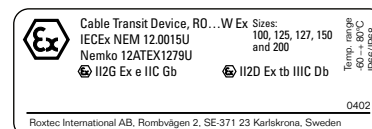

The following conditions for safe use (apparatus certified glands) and schedule of limitations (U-marked component certified glands) shall be considered according to the ATEX EC Type examination certificates and the IECEx Certificates of Conformity:

- For maintaining the explosion protection, the installation instructions that accompany the products shall be considered.
- Only cable for fixed installation is permitted for the cable entry.
- For optimum reliability, wait 24 hours or longer after installation before exposing the cables/pipes to strain or pressure.
- For cable glands certified as Ex components and marked with the symbol U (cable gland of type R...W), compliance with applicable requirements not covered by the sub-clauses stated below shall be verified. This includes mechanical test (if applicable) and test of degree of protection IP, which shall be carried out on the frame of the cable entry (excluding modules and compression unit) after it has been mounted on the enclosure of the apparatus subject to test and certification.

IEC 60079-0:2011

1, 2, 3, 4.2, 4.3, 5.2 (with respect of temperature limits), 6.1, 6.2, 7.1.1, 7.1.2.3, 7.2.1, 7.2.2, 7.5, 8.1, 8.3, 8.4, 13.1, 13.2, 13.4, 13.5, 16.3, 24, 25, 26.1, 26.2 (with respect of internal ingress protection), 26.4.1.1, 26.4.1.2, 26.4.1.2.2, 26.4.2, 26.4.4, 26.4.5.1 (with respect of internal ingress protection), 26.4.5.2, 26.7.1, 26.7.2, 26.8, 26.9, 29.1, 29.2, 29.4, 29.5, 29.9, 30.1, A.1, A.2.1, A.2.3, A.2.4.1, A.2.5, A.2.6, A.2.7, A.3.1.1, A.3.1.4, A.3.1.5, A.3.2.2, A.3.3, A.3.4 (with respect of internal ingress protection), A.4.1, A.4.2 and B.1.

EN 60079-0:2012

ZA

IEC 60079-31:2008

1, 2, 3, 4, 4.1, 5.2.1, 6.1.1 (with respect of internal ingress protection) and 7.

EN 60079-31:2009

ZA

DISCLAIMER

"The Roxtec cable entry sealing system ("the Roxtec system") is a modular-based system of sealing products consisting of different components. Each and every one of the components is necessary for the best performance of the Roxtec system. The Roxtec system has been certified to resist a number of different hazards. Any such certification, and the ability of the Roxtec system to resist such hazards, is dependent on all components that are installed as a part of the Roxtec system. Thus, the certification is not valid and does not apply unless all components installed as part of the Roxtec system are manufactured by or under license from Roxtec ("authorized manufacturer"). Roxtec gives no performance guarantee with respect to the Roxtec system, unless (I) all components installed as part of the Roxtec system are manufactured by an authorized manufacturer and (II) the purchaser is in compliance with (a), and (b), below.

(a) During storage, the Roxtec system or part thereof, shall be kept indoors in its original packaging at room temperature.

(b) Installation shall be carried out in accordance with Roxtec installation instructions in effect from time to time.

The product information provided by Roxtec does not release the purchaser of the

Roxtec system, or part thereof, from the obligation to independently determine the suitability of the products for the intended process, installation and/or use. Roxtec gives no guarantee for the Roxtec system or any part thereof and assumes no liability for any loss or damage whatsoever, whether direct, indirect, consequential, loss of profit or otherwise, occurred or caused by the Roxtec systems or installations containing components not manufactured by an authorized manufacturer and/or occurred or caused by the use of the Roxtec system in a manner or for an application other than for which the Roxtec system was designed or intended.

Roxtec expressly excludes any implied warranties of merchantability and fitness for a particular purpose and all other express or implied representations and warranties provided by statute or common law. User determines suitability of the Roxtec system for intended use and assumes all risk and liability in connection therewith. In no event shall Roxtec be liable for indirect, consequential, punitive, special, exemplary or incidental damages or losses."



Roxtec International AB
Box 540, 371 23 Karlskrona, SWEDEN
PHONE +46 455 36 67 00, FAX +46 455 820 12
EMAIL info@roxtec.com, www.roxtec.com