

General information

Installation and maintenance:

For European member countries of GENELEC, shall standard EN 60079-14 and EN 60079-17 be considered.

For countries members of IECEx shall standard IEC 60079-14 and IEC 60079-17 be considered.

For other countries shall applicable national regulation be considered.

The products fulfill the following standards:

EN 60079-0:2012, EN 60079-31:2009
IEC 60079-0:2011, IEC 60079-31:2008



Installation instructions Cable transit device CF 8-, CF 32 Ex

The cable transit devices are intended for use with permanently installed circular cross-section cables, with or without armoring or braided screen. The cable entry may also be used with permanently installed cables of types TECK90 according to standard C22.2 No. 131-07, ACWU according to standard UL4, MC according to standard UL1569 and ACIC cables according to CSA C22.1-06 CEC UL444, UL1685, UL13, UL2250, IEC61158-2.

For bonding and grounding applications when using CM BG™ or CM BG™ B modules, the installation instructions for those modules shall be used. For EMC applications when using CM PE- or CM ES modules, the installation instruction for those modules shall be used.

Parts

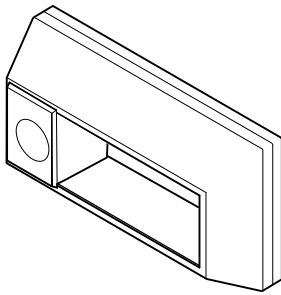

Roxtec CF 8 Ex

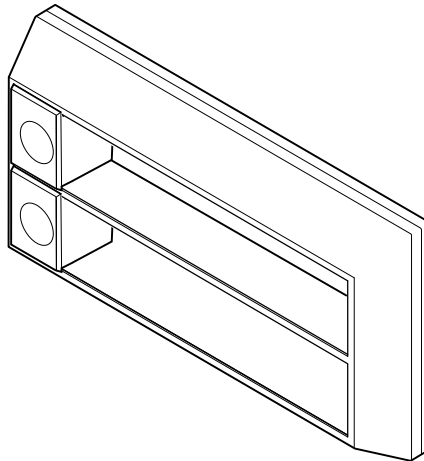

Roxtec CF 32 Ex

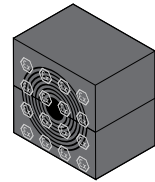

CM Ex module

Aperture dimensions

CF 8 Ex

Hole dimensions in cabinet:

	(mm)	(in)
H	127±0.5	5.000±0.02
W	61±0.5	2.402±0.02

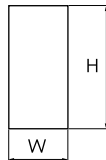

CF 32 Ex

Hole dimensions in cabinet:

	(mm)	(in)
H	216±0.5	8.504±0.02
W	110±0.5	4.331±0.02

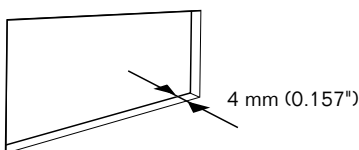
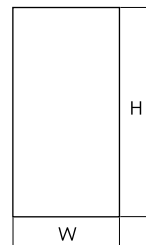

Max wall thickness

Installation

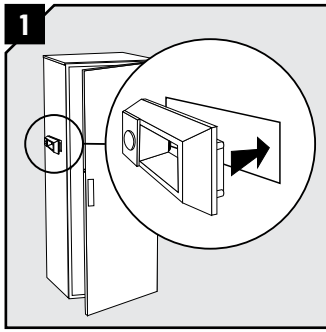

Insert the CF frame (pic. 1) from the outside, and the counter frame (pic. 2) from the inside.

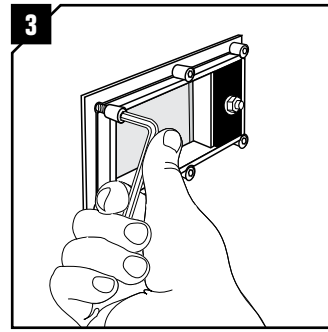
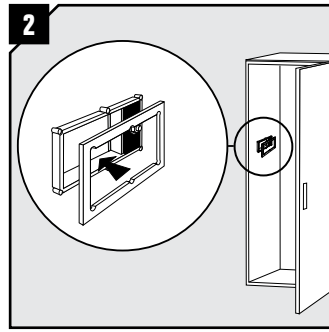

Fasten the hexagon nuts on the backside.

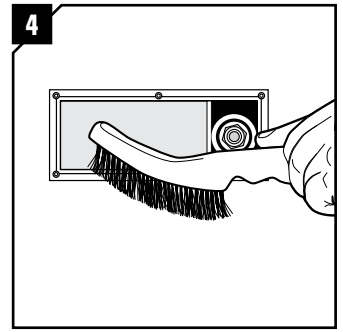

Clean the inside of the frame.

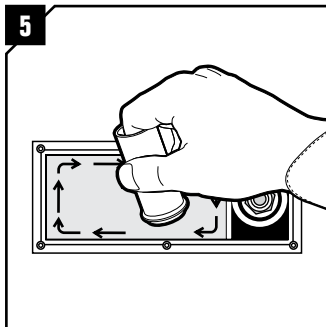

Lubricate the inside faces of the frame. Make sure to get lubricant into the corners.

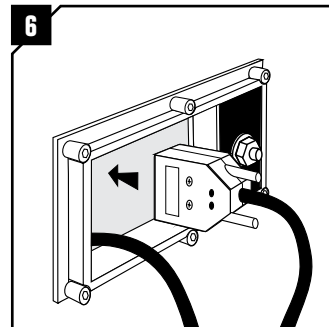

Insert the cables through the frame.

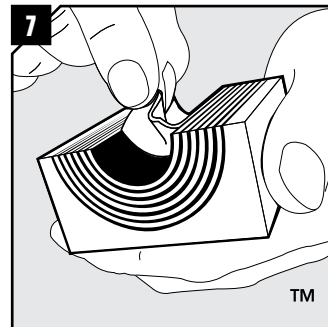

Adapt modules which are to hold cables or pipes by peeling off layers. The halves may not differ by more than one layer.

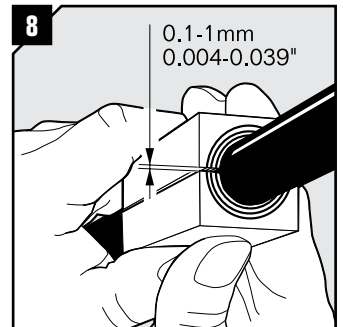

Try to achieve a 0.1–1 mm gap between the two halves when held against the cable/pipe. Use the Ex Gap Gauge.

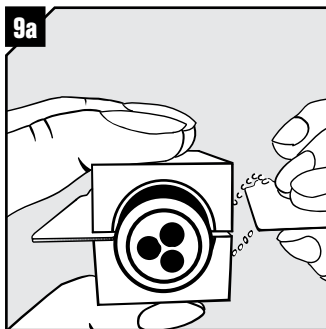

Measure the gap with the Ex Gap Gauge by holding blade one in one gap and checking the other with blade two.

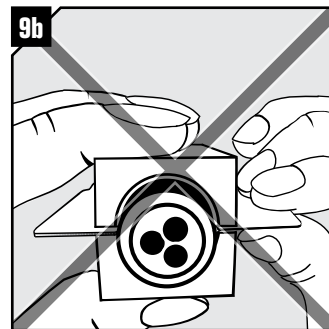

If the gap is too big, the gauge will slip in easily.

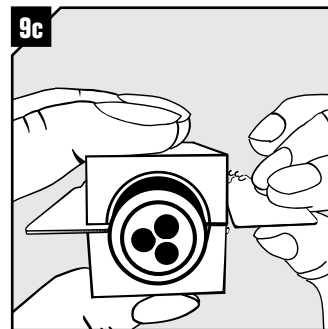

If the gap is correct, there will be no room for blade two.

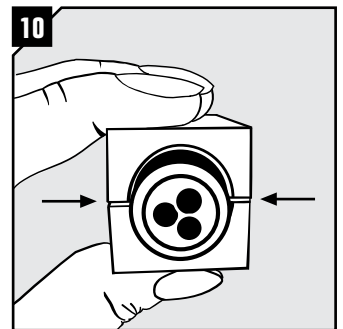

When checking without the gauge, there shall be a visual gap.

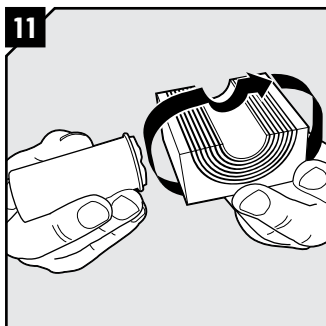

Lubricate the modules thoroughly with Roxtec Lubricant, both the inside and outside faces.

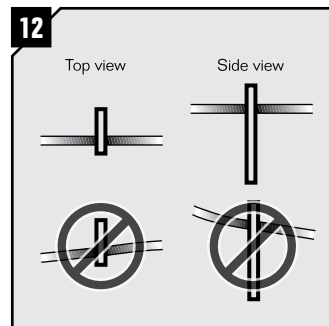

Note that cables shall go straight through the frame.

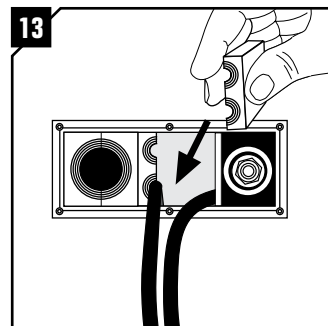

Insert the modules from the inside of the cabinet.

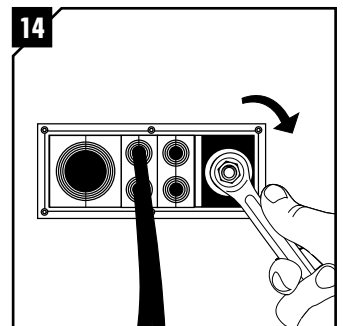

Tighten the compression unit. Minimum 8 Nm.

The ingress protection of the cable transit device varies depending on configuration according to the table below

Configuration	IP-class
Corrugated cable	IP 65
Circular cross-section, smooth shape	IP 66/IP 67

Disassembly

Reverse order

Note

- An incorrectly adapted seal shall be replaced (layers shall not be reused).
- Temperature range -40 to +80°C.
- Permitted Roxtec modules: CM Ex type.
- You find EC Type examination certificate at www.roxtec.com, or contact your local Roxtec supplier.

The following conditions for safe use shall be considered according to the ATEX EC Type Examination certificate and the IECEx Certificate of Conformity:

- 1 For maintaining the explosion protection, the installation instructions that accompany the products shall be considered.
- 2 Only cable for fixed installation is permitted for the cable entry.
- 3 For optimum reliability wait 24 hours or longer after installation before exposing the cables/pipes to strain or pressure.

Standard adaptable modules Ex

Module	Number of cables/pipes	For cable/pipe diameter	
		a-b (mm)	a-b (in)
CM 15w40 Ex	3	0+3.5-10.5	0+ 0.138-0.413
CM 20 Ex	1	0+4.0-14.5	0+ 0.157-0.571
CM 20w40 Ex	2	0+3.5-16.5	0+ 0.138-0.650
CM 30w40 Ex	1	0+10.0-25.0	0+ 0.394-0.984
CM 40 Ex	1	0+21.5-34.5	0+ 0.846-1.358
CM 40 10-32 Ex	1	0+9.5-32.5	0+ 0.374-1.280

Solid compensation modules Ex

Module
CM 5w40/0 Ex
CM 10w40/0 Ex
CM 20/0 Ex
CM 40/0 Ex

Single diameter modules Ex

Module
CM 20/14 Ex
CM 20/15 Ex
CM 20/16 Ex
CM 40/34 Ex
CM 40/36 Ex

Frame label:

Year of manufacture → XXXX

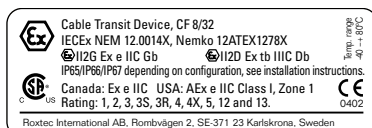

UKCA conformity marking

Can only be applied together with the ATEX and IECEx main frame label.



DISCLAIMER

"The Roxtec cable entry sealing system ("the Roxtec system") is a modular-based system of sealing products consisting of different components. Each and every one of the components is necessary for the best performance of the Roxtec system. The Roxtec system has been certified to resist a number of different hazards. Any such certification, and the ability of the Roxtec system to resist such hazards, is dependent on all components that are installed as a part of the Roxtec system. Thus, the certification is not valid and does not apply unless all components installed as part of the Roxtec system are manufactured by or under license from Roxtec ("authorized manufacturer"). Roxtec gives no performance guarantee with respect to the Roxtec system, unless (I) all components installed as part of the Roxtec system are manufactured by an authorized manufacturer and (II) the purchaser is in compliance with (a), and (b), below.

(a) During storage, the Roxtec system or part thereof, shall be kept indoors in its original packaging at room temperature.

(b) Installation shall be carried out in accordance with Roxtec installation instructions in effect from time to time.

The product information provided by Roxtec does not release the purchaser of the

Roxtec system, or part thereof, from the obligation to independently determine the suitability of the products for the intended process, installation and/or use. Roxtec gives no guarantee for the Roxtec system or any part thereof and assumes no liability for any loss or damage whatsoever, whether direct, indirect, consequential, loss of profit or otherwise, occurred or caused by the Roxtec systems or installations containing components not manufactured by an authorized manufacturer and/or occurred or caused by the use of the Roxtec system in a manner or for an application other than for which the Roxtec system was designed or intended.

Roxtec expressly excludes any implied warranties of merchantability and fitness for a particular purpose and all other express or implied representations and warranties provided by statute or common law. User determines suitability of the Roxtec system for intended use and assumes all risk and liability in connection therewith. In no event shall Roxtec be liable for indirect, consequential, punitive, special, exemplary or incidental damages or losses."



Roxtec International AB
Box 540, 371 23 Karlskrona, SWEDEN
PHONE +46 455 36 67 00, FAX +46 455 820 12
EMAIL info@roxtec.com, www.roxtec.com