

## General information

Installation and maintenance:

For European member countries of GENELEC shall standard EN 60079-14 and EN 60079-17 be considered.

For countries members of IECEx shall standard IEC 60079-14 and IEC 60079-17 be considered.

For other countries shall applicable national regulations be considered.

The products fulfill the following standards:

EN 60079-0:2012, EN 60079-31:2009

IEC 60079-0:2011, IEC 60079-31:2008



## Installation instructions Ex frames

The frames are intended for use with permanently installed circular cross-section cables, with or without armoring or braided screen. Cable transit devices of types G, S, SF, SF..W and G..W may also be used with permanently installed corrugated cables of types TECK90 according to standard C22.2 No. 131-07, ACWU according to standard UL4, MC according to standard UL1569 and ACIC cables according to CSA C22.1-06 CEC UL444, UL1685, UL13, UL2250, IEC61158-2.

The frames are intended for use with sealing modules, stayplates and compression units of Ex types.

For complete installation with Roxtec RM Ex and RM Ex EMC modules, see installation instructions art. no. 126175.

### Ex frames

The following frames are approved for Ex use.

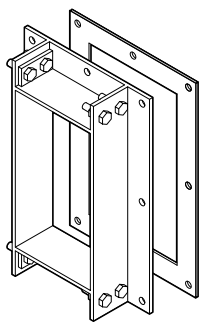

B..B Ex

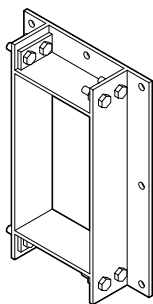

B..C Ex

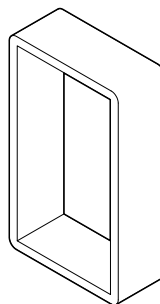

S Ex

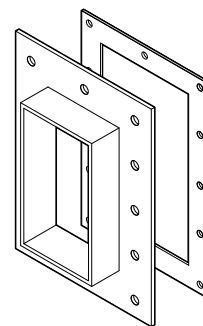

G Ex

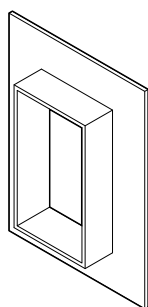

G..W Ex

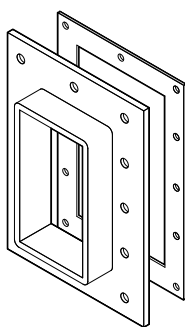

SF Ex

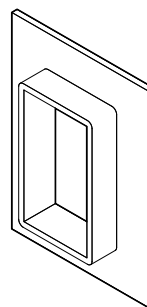

SF..W Ex

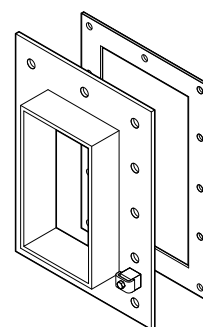

G BG B Ex

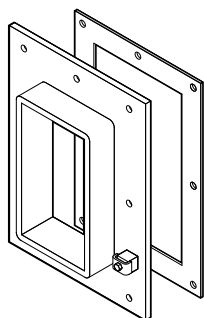

SF BG Ex

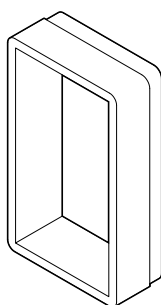

S..WM Ex

## B...B Ex frame installation

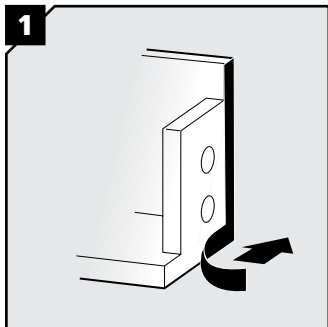

Remove the protective foil from the sealing strip on every shortside.

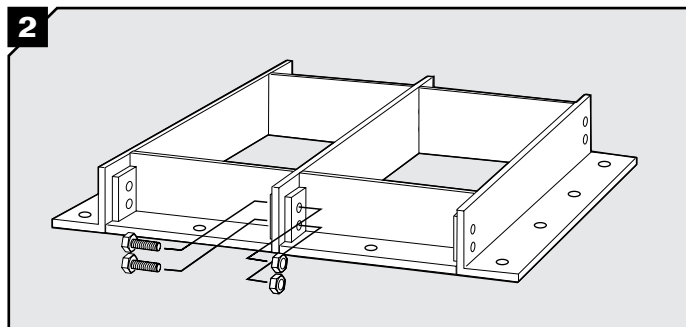

Assemble the frame by inserting the bolts and tightening the nuts. The frame can easily be assembled around already routed cables or pipes.

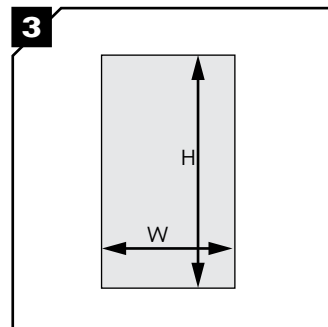

Mark a rectangular opening according to frame type (see table below).

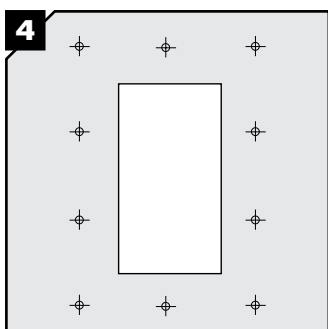

Use the frame as template for the drilling of the screw holes. Drill  $\varnothing = 8.5$  mm.

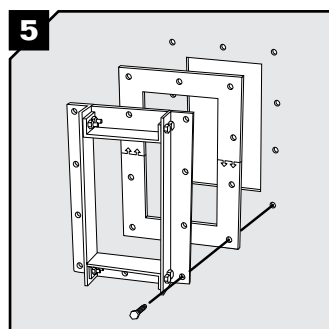

Attach the frame to the cabinet/wall using bolts and nuts (not included). Place the gasket between the frame and the cabinet/structure. Use the enclosed glue on both splices to assemble the openable gasket. Consider glue instructions for safe use.

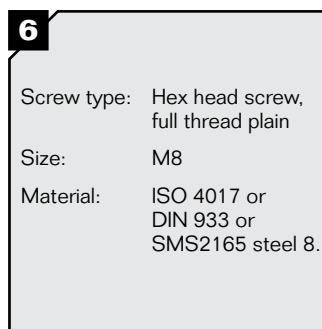

Minimum quality.

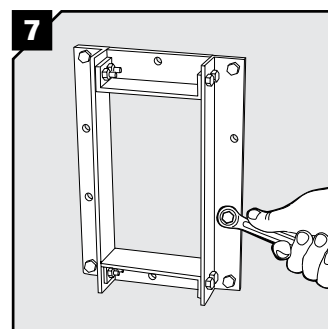

Note: Tighten the screws to minimum 8 Nm.

## B...B Ex aperture dimensions for bolted installations

Frame size	Height		Width (mm)/(in)				
	(mm)	(in)	x1	x2	x3	x4	x5
2	126	4.961	146	274	403	531	670
4	185	7.283					

Theoretically recommended dimensions.

Frame size	Height		Width (mm)/(in)				
	(mm)	(in)	x1	x2	x3	x4	x5
6	243	9.567	5.748	10.787	15.866	20.906	26.378
8	303	11.929					

Theoretically recommended dimensions.

## B...C Ex frame installation for cast installation

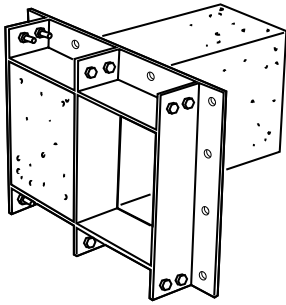

For correct casting of frames into concrete structures, casting moulds in cellular plastic are available.

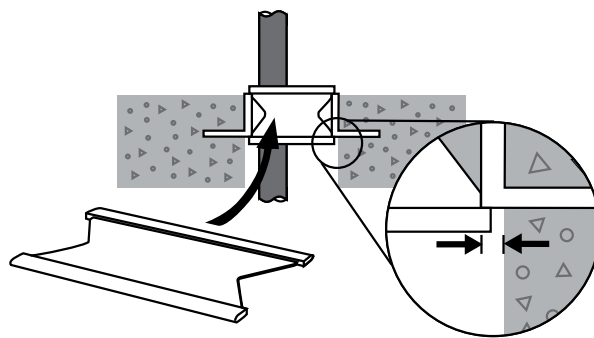

To allow for a correct installation, the size of the opening in the wall must be 5 mm (0.197") wider than the inside dimensions of the frame on all sides. The reason is that the stayplates and the wedge need this space to be able to move inside the frame during installation and compression.

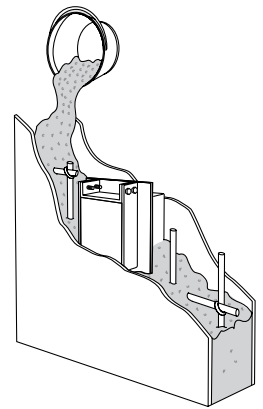

Before concrete is poured, the frame and casting mould are fixed in position with the frame flange inside the structure.

## S Ex frame installation

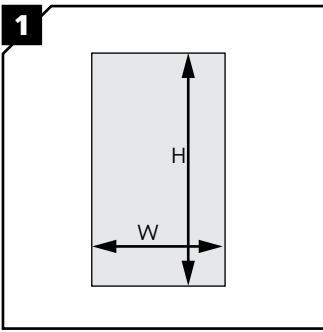

Mark a rectangular opening according to frame type (see table below).

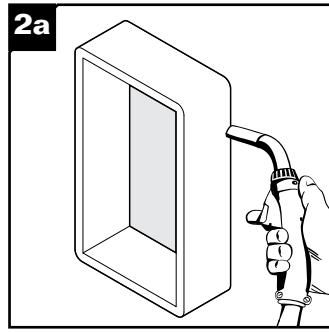

Weld the S frame to the cabinet/wall. (Suggestion for welding instructions is available).

## S Ex frame, aperture dimensions for welded installations

Frame size	Height				Width (mm)/(in)									
	1 opening in width		>1 opening in width		x1	x2	x3	x4	x5	x6	x7	x8	x9	x10
	(mm)	(in)	(mm)	(in)										
1	123	4.843	123	4.483										
1+1	234	9.213	244	9.606	82	153	224	294	365	435	506	576	647	717
1+1+1	345	13.583	365	14.370	3.228	6.024	8.819	11.575	14.370	17.126	19.921	22.677	25.472	28.228
2	123	4.843	123	4.843										
2+2	234	9.213	244	9.606	143	273	404	534	665	795	926	1056	1186	1317
2+2+2	345	13.583	365	14.370	5.630	10.748	15.906	21.024	26.181	31.299	36.457	41.575	46.693	51.850
3	182	7.165	182	7.165										
3+3	351	13.819	361	14.213	82	153	224	294	365	435	506	576	647	717
3+3+3	521	20.512	541	21.299	3.228	6.024	8.819	11.575	14.370	17.126	19.921	22.677	25.472	28.228
4	182	7.165	182	7.165										
4+4	351	13.819	361	14.213	143	273	404	534	665	795	926	1056	1186	1317
4+4+4	521	20.512	541	21.299	5.630	10.748	15.906	21.024	26.181	31.299	36.457	41.575	46.693	51.850
5	240	9.449	240	9.449										
5+5	468	18.425	478	18.819	82	153	224	294	365	435	506	576	647	717
5+5+5	696	27.402	716	28.189	3.228	6.024	8.819	11.575	14.370	17.126	19.921	22.677	25.472	28.228
6	240	9.449	240	9.449										
6+6	468	18.425	478	18.819	143	273	404	534	665	795	926	1056	1186	1317
6+6+6	696	27.402	716	28.189	5.630	10.748	15.906	21.024	26.181	31.299	36.457	41.575	46.693	51.850
7	300	11.811	300	11.811										
7+7	588	23.150	598	23.543	82	153	224	294	365	435	506	576	647	717
7+7+7	876	34.488	896	35.276	3.228	6.024	8.819	11.575	14.370	17.126	19.921	22.677	25.472	28.228
8	300	11.811	300	11.811										
8+8	588	23.150	598	23.543	143	273	404	534	665	795	926	1056	1186	1317
8+8+8	876	34.488	896	35.276	5.630	10.748	15.906	21.024	26.181	31.299	36.457	41.575	46.693	51.850

Theoretically recommended dimensions.

## S...WM Ex frame installation

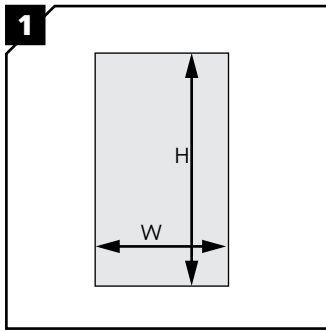

Mark a rectangular opening according to frame type (see table below).

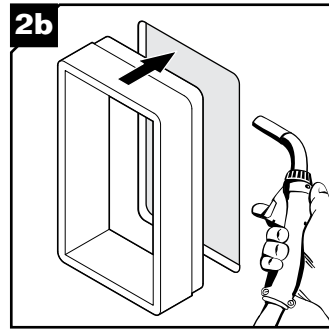

Insert and weld the S...WM frame to the cabinet/wall. (Suggestion for welding instructions is available).

## S...WM frame, aperture dimensions for welded installations

Frame size	Height				Width (mm)/(in)				
	1 opening in width		>1 opening in width		x1	x2	x3	x4	x5
	(mm)	(in)	(mm)	(in)					
1	97	3.82	97	3.82					
1+1	228	8.98	238	9.37	76,5	147	217,5	288	358.5
1+1+1	339	13.35	359	14.13	3.01	5.79	8.56	11.34	14.11
2	97	3.82	97	3.82					
2+2	228	8.98	238	9.37	136,5	267	397,5	528	658.5
2+2+2	339	13.35	359	14.13	5.37	10.51	15.65	20.79	25.93
3	175.5	6.9	344.5	13.56					
3+3	344.5	13.56	354.5	13.96	76,5	147	217,5	288	358.5
3+3+3	514.5	20.25	534.5	21.04	3.01	5.79	8.56	11.34	14.11
4	175.5	6.9	175.5	6.9					
4+4	344.5	13.56	354.5	13.96	136,5	267	397,5	528	658.5
4+4+4	514.5	20.25	534.5	21.04	5.37	10.51	15.65	20.79	25.93
5	233.5	9.19	233.5	9.19					
5+5	461.5	18.17	471.5	18.56	76,5	147	217,5	288	358.5
5+5+5	687.5	27.07	707.5	27.85	3.01	5.79	8.56	11.34	14.11
6	233.5	9.19	233.5	9.19					
6+6	461.5	18.17	471.5	18.56	136,5	267	397,5	528	658.5
6+6+6	687.5	27.07	707.5	27.85	5.37	10.51	15.65	20.79	25.93
7	293.5	11.55	293.5	11.55					
7+7	581.5	22.89	591.5	23.29	76,5	147	217,5	288	358.5
7+7+7	875.5	34.47	895.5	35.25	3.01	5.79	8.56	11.34	14.11
8	293.5	11.55	293.5	11.55					
8+8	581.5	22.89	591.5	23.29	136,5	267	397,5	528	658.5
8+8+8	875.5	34.47	895.5	35.25	5.37	10.51	15.65	20.79	25.93

Theoretically recommended dimensions.

## G Ex, G BG B Ex, SF Ex, SF BG Ex frame installation

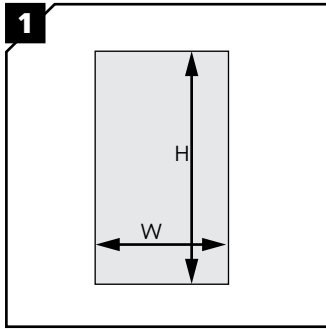

1 Mark a rectangular opening according to frame type (see table below).

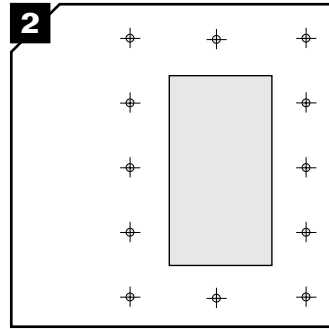

2 Use the frame as template for the drilling of the screw holes. Drill  $\varnothing = 8.5$  mm.

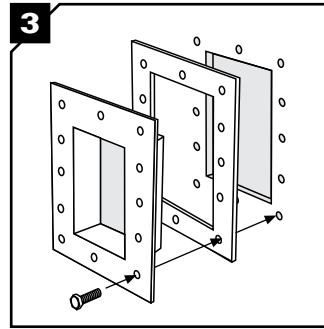

3 Attach the frame to the cabinet/wall using bolts and nuts (not included). The rubber gasket shall be placed between frame and cabinet/wall.

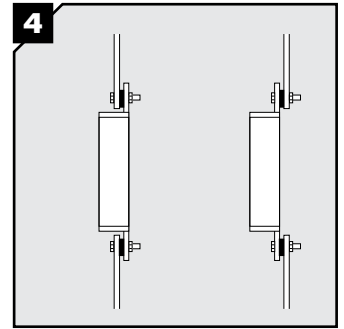

4 Alternative frame installation.



Minimum quality.

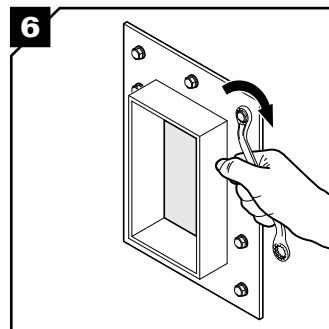

6 Note: Tighten the screws to minimum 8 Nm.

## G Ex, G BG B Ex frame, aperture dimensions for bolted installations

Frame size	Height				Width (mm)/(in)									
	1 opening in width		>1 opening in width		x1	x2	x3	x4	x5	x6	x7	x8	x9	x10
	(mm)	(in)	(mm)	(in)										
1	133	5.236	133	5.236	92	163	233	304	374	445	515	586	656	727
1+1	244	9.606	246	9.685	3.622	6.417	9.173	11.969	14.724	17.520	20.276	23.071	25.827	28.622
1+1+1	355	13.976	359	14.134										
2	133	5.236	133	5.236	152	283	413	544	674	805	935	1066	1196	1327
2+2	244	9.606	246	9.685	5.984	11.142	16.260	21.417	26.535	31.693	36.811	41.969	47.087	52.244
2+2+2	355	13.976	359	14.133										
3	191	7.520	191	7.520	92	163	233	304	374	445	515	586	656	727
3+3	361	14.213	363	14.291	3.622	6.417	9.173	11.969	14.724	17.520	20.276	23.071	25.827	28.622
3+3+3	530	20.866	534	21.024										
4	191	7.520	191	7.520	152	283	413	544	674	805	935	1066	1196	1327
4+4	361	14.213	363	14.291	5.984	11.142	16.260	21.417	26.535	31.693	36.811	41.968	47.087	52.244
4+4+4	530	20.866	534	21.024										
5	250	9.843	250	9.843	92	163	233	304	374	445	515	586	656	727
5+5	478	18.819	480	18.898	3.622	6.417	9.173	11.969	14.724	17.520	20.276	23.071	25.827	28.622
5+5+5	706	27.795	710	27.953										
6	250	9.843	250	9.843	152	283	413	544	674	805	935	1066	1196	1327
6+6	478	18.819	480	18.898	5.984	11.142	16.260	21.417	26.535	31.693	36.811	41.968	47.087	52.244
6+6+6	706	27.795	710	27.953										
7	310	12.205	310	12.205	92	163	233	304	374	445	515	586	656	727
7+7	598	23.543	600	23.622	3.622	6.417	9.173	11.969	14.724	17.520	20.276	23.071	25.827	28.622
7+7+7	886	34.882	890	35.039										
8	310	12.205	310	12.205	152	283	413	544	674	805	935	1066	1196	1327
8+8	598	23.543	600	23.622	5.984	11.142	16.260	21.417	26.535	31.693	36.811	41.968	47.087	52.244
8+8+8	886	34.882	890	35.039										

Theoretically recommended dimensions.

## G BG B Ex, SF BG Ex frame installation

The frame shall be connected to the desired ground point. The grounding connector and terminal shall be sized according to the requirements for the actual installation and are not included in the Roxtec delivery.

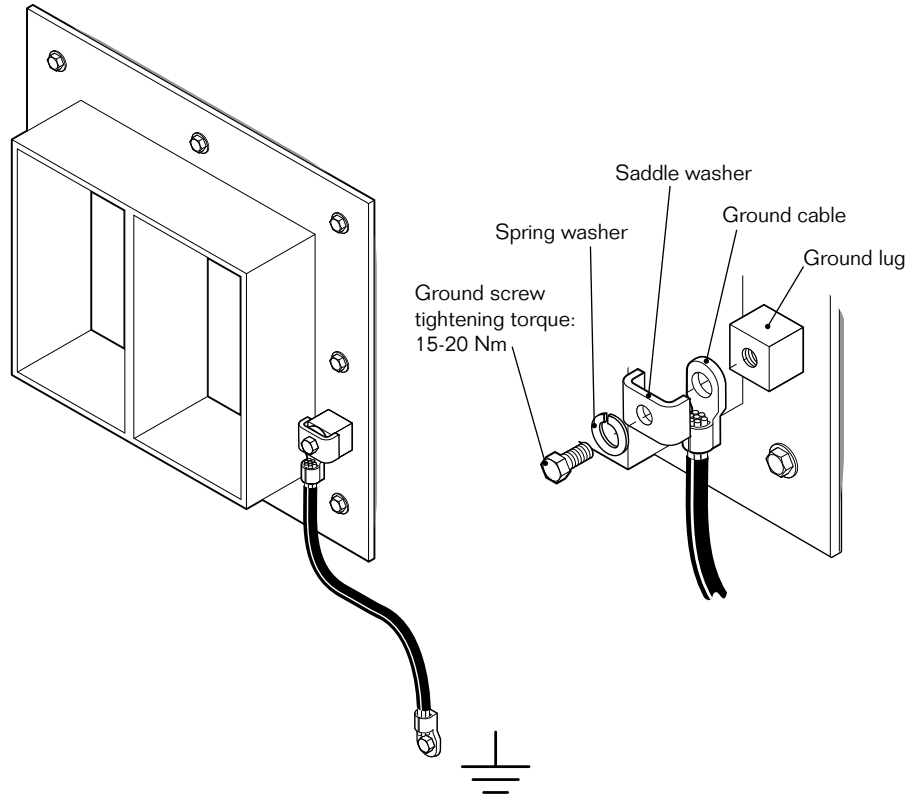

## SF Ex, SF BG B frame, aperture dimensions for bolted installations

Frame size	Height				Width (mm)/(in)									
	1 opening in width		>1 opening in width		x1	x2	x3	x4	x5	x6	x7	x8	x9	x10
	(mm)	(in)	(mm)	(in)										
1	141	5.551	141	5.551										
1+1	252	9.213	262	10.315	100	171	242	312	383	453	524	594	664	735
1+1+1	363	14.291	383	15.079	3.937	6.732	9.528	12.283	15.079	17.835	20.630	23.386	26.142	28.937
2	141	5.551	141	4.409										
2+2	252	9.921	262	10.315	160	291	422	552	683	813	944	1074	1205	1335
2+2+2	363	14.291	383	-	6.299	11.457	16.614	21.732	26.890	32.008	37.165	42.283	47.441	52.559
3	199	7.835	199	7.835										
3+3	369	14.528	379	14.921	100	171	242	312	383	453	524	594	664	735
3+3+3	538	21.181	558	21.969	3.937	6.732	9.528	12.283	15.079	17.835	20.630	23.386	26.142	28.937
4	199	7.835	199	7.835										
4+4	369	14.528	379	14.921	160	291	422	552	683	813	944	1074	1205	1335
4+4+4	538	21.181	558	21.969	6.299	11.457	16.614	21.732	26.890	32.008	37.165	42.283	47.441	52.559
5	258	10.157	258	10.157										
5+5	486	19.134	496	19.528	100	171	242	312	383	453	524	594	664	735
5+5+5	714	28.110	734	28.898	3.937	6.732	9.528	12.283	15.079	17.835	20.630	23.386	26.142	28.937
6	258	10.157	258	10.157										
6+6	486	19.134	496	19.528	160	291	422	552	683	813	944	1074	1205	1335
6+6+6	714	28.110	734	28.898	6.299	11.457	16.614	21.732	26.890	32.008	37.165	42.283	47.441	52.559
7	318	12.520	318	12.520										
7+7	606	23.858	616	24.252	100	171	242	312	383	453	524	594	664	735
7+7+7	894	35.197	914	35.984	3.937	6.732	9.528	12.283	15.079	17.835	20.630	23.386	26.142	28.937
8	318	12.520	318	12.520										
8+8	606	23.858	616	24.252	160	291	422	552	683	813	944	1074	1205	1335
8+8+8	894	35.197	914	35.984	6.299	11.457	16.614	21.732	26.890	32.008	37.165	42.283	47.441	52.559

Theoretically recommended dimensions.

## G...W Ex and SF..W Ex frame installation

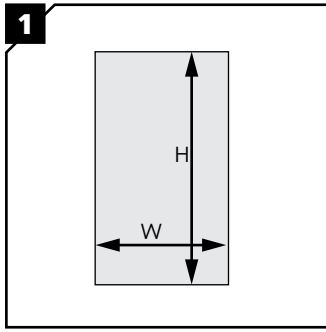

1 Mark a rectangular opening according to frame type (see table below).

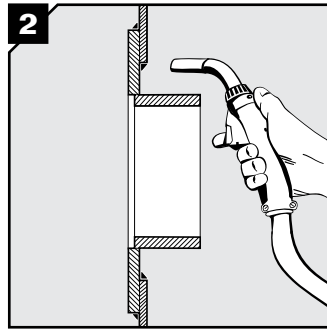

2 Weld the frame to the cabinet/wall. (Suggestion for welding instructions is available.)

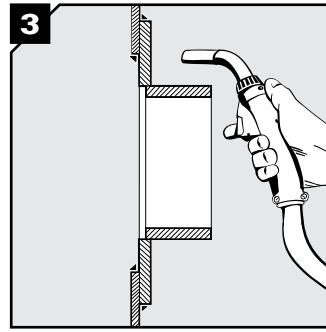

3 Alternative frame installation.

## G...W Ex and SF..W Ex frame, aperture dimensions for welded installations

Frame size	Height				Width (mm)/(in)									
	1 opening in width		>1 opening in width		x1	x2	x3	x4	x5	x6	x7	x8	x9	x10
	(mm)	(in)	(mm)	(in)										
1	181	7.126	181	7.126										
1+1	292	11.496	302	11.890	140	211	282	352	423	493	564	634	705	775
1+1+1	403	15.866	423	16.654	5.512	8.307	11.102	13.858	16.654	19.409	22.205	24.961	27.756	30.512
2	181	7.126	181	7.126										
2+2	292	11.496	302	11.890	201	331	462	592	723	853	984	1114	1244	1375
2+2+2	403	15.866	423	16.654	7.913	13.031	18.189	23.307	28.465	33.583	38.740	43.858	48.976	54.134
3	240	9.449	240	9.499										
3+3	409	16.102	419	16.496	140	211	282	352	423	493	564	634	705	775
3+3+3	579	22.795	599	23.583	5.512	8.307	11.102	13.858	16.654	19.409	22.205	24.961	27.756	30.512
4	240	9.449	240	9.449										
4+4	409	16.102	419	16.496	201	331	462	592	723	853	984	1114	1244	1375
4+4+4	579	22.795	599	23.583	7.913	13.031	18.189	23.307	28.465	33.583	38.740	43.858	48.976	54.134
5	298	11.732	298	11.732										
5+5	526	20.709	536	21.102	140	211	282	352	423	493	564	634	705	775
5+5+5	754	29.685	774	30.472	5.512	8.307	11.102	13.858	16.654	19.409	22.205	24.961	27.756	30.512
6	298	11.732	298	11.732										
6+6	526	20.709	536	21.102	201	331	462	592	723	853	984	1114	1244	1375
6+6+6	754	29.685	774	30.472	7.913	13.031	18.189	23.307	28.465	33.583	38.740	43.858	48.976	54.134
7	358	14.094	358	14.094										
7+7	646	25.433	656	25.827	140	211	282	352	423	493	564	634	705	775
7+7+7	935	36.811	955	37.598	5.512	8.307	11.102	13.858	16.654	19.409	22.205	24.961	27.756	30.512
8	358	14.094	358	14.094										
8+8	646	25.433	656	25.827	201	331	462	592	723	853	984	1114	1244	1375
8+8+8	935	36.811	955	37.598	7.913	13.031	18.189	23.307	28.465	33.583	38.740	43.858	48.976	54.134

Theoretically recommended dimensions.



## Frame sizes

Frames of S type shown below.

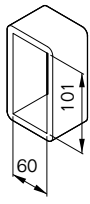

S 1

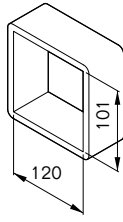

S 2

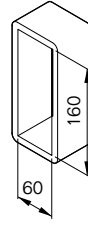

S 3

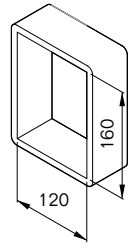

S 4

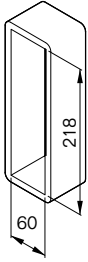

S 5

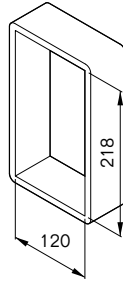

S 6

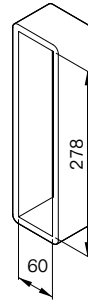

S 7

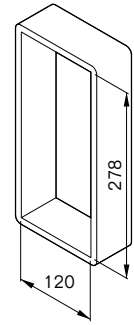

S 8

## Examples of S 6 combination frames

S = Type of frame

Z = Frame size

N = Number of frames horizontally

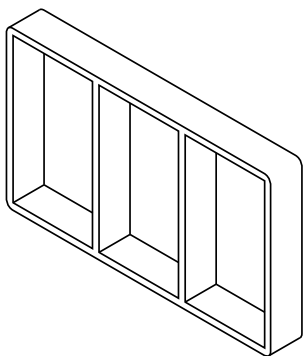

(S ZxN)  
S 6x3

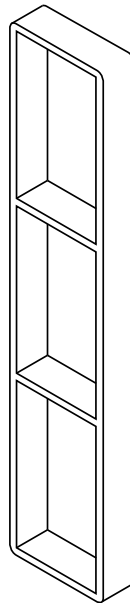

(S Z+Z+ZxN)  
S 6+6x1

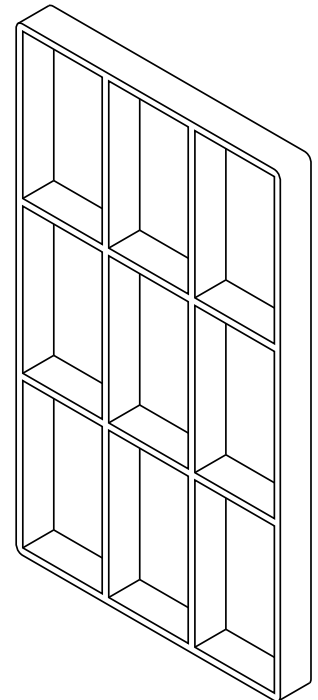

(S Z+Z+ZxN)  
S 6+6+6x3

## Note

- Temperature range -60 to +80° C.
- You find EC Type examination certificate on [www.roxtec.com](http://www.roxtec.com), or contact your local Roxtec supplier.

The following conditions for safe use (apparatus certified cable transit device) and schedule of limitations (U-marked component certified cable transit devices) shall be considered according to the ATEX EC Type Examination certificates and the IECEx Certificates of Conformity:

- 1 In order to maintain the explosion protection, the installation instructions for frame installation and module installation shall be considered.
- 2 Only cable for fixed installation is permitted for the cable entry.
- 3 For optimum reliability, wait 24 hours or longer after installation before exposing the cables/pipes to strain or pressure.
- 4 For cable transit devices certified as Ex components and marked with the symbol U (cable transit devices of types B...C, G...W, S..., S...S0..., SF...W and S...WM), compliance with applicable requirements not covered by the sub-clauses stated below, shall be verified. This includes mechanical test (if applicable) and test of degree of protection IP, which shall be carried out on the frame of the cable entry (excluding modules and compression unit) after it has been mounted on the enclosure of the apparatus subject to test and certification.

IEC 60079-0:2011

1, 2, 3, 4.2, 4.3, 5.2 (with respect of temperature limits), 6.1, 6.2, 7.1.1, 7.1.2.3, 7.2.1, 7.2.2, 7.5, 8.1, 8.3, 8.4, 13.1, 13.2, 13.4, 13.5, 16.3, 24, 25, 26.1, 26.2 (with respect of internal ingress protection), 26.4.1.1, 26.4.1.2, 26.4.1.2.2, 26.4.2, 26.4.4, 26.4.5.1 (with respect of internal ingress protection), 26.4.5.2, 26.7.1, 26.7.2, 26.8, 26.9, 29.1, 29.2, 29.4, 29.5, 29.9, 30.1, A.1, A.2.1, A.2.3, A.2.4.1, A.2.5, A.2.6, A.2.7, A.3.1.1, A.3.1.4, A.3.1.5, A.3.2.2, A.3.3, A.3.4 (with respect of internal ingress protection), A.4.1, A.4.2 and B.1.

EN 60079-0:2012

ZA

IEC 60079-31:2008

1, 2, 3, 4, 4.1, 5.2.1, 6.1.1 (with respect of internal ingress protection) and 7.

EN 60079-31:2009

ZA

**Frame label:**

**B...B Ex frame**

**Cable Transit Device, B...B**

 IECEx NEM 12.0014X  
 Ⓢ II2G Ex e IIC Gb  
 Ⓢ II2D Ex tb IIIC Db  
 Nemko 12ATEX1278X

Sizes:  
 B 2x1 B – B 2x5 B    B 6x1 B – B 6x5 B  
 B 4x1 B – B 4x5 B    B 8x1 B – B 8x5 B

 0402

Temp. range -60 — + 80°C  
 IP66

Roxtec International AB  
 Rombvägen 2  
 SE-371 23 Karlskrona, Sweden

**B...C Ex frame**

**Cable Transit Device, B...C**

 IECEx NEM 12.0015U  
 Ⓢ II2G Ex e IIC Gb  
 Ⓢ II2D Ex tb IIIC Db  
 Nemko 12ATEX1279U

Sizes:  
 B 2x1 C – B 2x5 C    B 6x1 C – B 6x5 C  
 B 4x1 C – B 4x5 C    B 8x1 C – B 8x5 C

 0402

Temp. range -60 — + 80°C  
 IP66

Roxtec International AB  
 Rombvägen 2  
 SE-371 23 Karlskrona, Sweden

**S Ex frame**

**Cable Transit Device, S...**

 IECEx NEM 12.0015U  
 Ⓢ II2G Ex e IIC Gb  
 Ⓢ II2D Ex tb IIIC Db  
 Nemko 12ATEX1279U

Frame size 1-8 and combinations thereof  
 Min S 1x1 to Max S 8+8+8x10

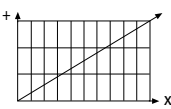

 0402

Temp. range -60 — + 80°C  
 IP65/IP66/IP67 depending on configuration,  
 see installation instruction.

 Canada: Ex e IIC USA: AEx e IIC,  
 Class I, Zone 1  
 System environmental rating:  
 1, 2, 3, 3S, 3R, 4, 4X, 5, 12 and 13.

Roxtec International AB, Rombvägen 2  
 SE-371 23 Karlskrona, Sweden

**G Ex frame**

**Cable Transit Device, G...**

 IECEx NEM 12.0014X  
 Ⓢ II2G Ex e IIC Gb  
 Ⓢ II2D Ex tb IIIC Db  
 Nemko 12ATEX1278X

Frame size 1-8 and combinations thereof  
 Min G 1x1 to Max G 8+8+8x10

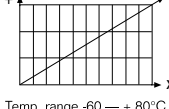

 0402

Temp. range -60 — + 80°C  
 IP65/IP66/IP67 depending on configuration,  
 see installation instruction.

 Canada: Ex e IIC USA: AEx e IIC,  
 Class I, Zone 1  
 System environmental rating:  
 1, 2, 3, 3S, 3R, 4, 4X, 5, 12 and 13.

Roxtec International AB, Rombvägen 2  
 SE-371 23 Karlskrona, Sweden

**G...W Ex frame**

**Cable Transit Device, G...W**

 IECEx NEM 12.0015U  
 Ⓢ II2G Ex e IIC Gb  
 Ⓢ II2D Ex tb IIIC Db  
 Nemko 12ATEX1279U

Frame size 1-8 and combinations thereof  
 Min G 1x1 W to Max G 8+8+8x10 W

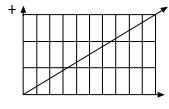

 0402

Temp. range -60 — + 80°C  
 IP65/IP66/IP67 depending on configuration,  
 see installation instruction.

 Canada: Ex e IIC USA: AEx e IIC,  
 Class I, Zone 1  
 System environmental rating:  
 1, 2, 3, 3S, 3R, 4, 4X, 5, 12 and 13.

Roxtec International AB, Rombvägen 2  
 SE-371 23 Karlskrona, Sweden

**SF Ex frame**

**Cable Transit Device, SF...**

 IECEx NEM 12.0014X  
 Ⓢ II2G Ex e IIC Gb  
 Ⓢ II2D Ex tb IIIC Db  
 Nemko 12ATEX1278X

Frame size 1-8 and combinations thereof  
 Min SF 1x1 to Max SF 8+8+8x10

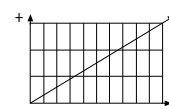

 0402

Temp. range -60 — + 80°C  
 IP65/IP66/IP67 depending on configuration,  
 see installation instruction.



Roxtec International AB, Rombvägen 2  
 SE-371 23 Karlskrona, Sweden

**S...WM Ex frame**

**Cable Transit Device, S...WM**

 IECEx NEM 12.0015U  
 Ⓢ II2G Ex e IIC Gb  
 Ⓢ II2D Ex tb IIIC Db  
 Nemko 12ATEX1279U

Frame size 1-8 and combinations thereof  
 Min S 1x1 WM to Max S 8+8+8x5 WM

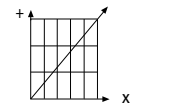

 0402

Temp. range -60 — + 80°C  
 IP65/IP66/IP67 depending on configuration,  
 see installation instruction.

Roxtec International AB, Rombvägen 2  
 SE-371 23 Karlskrona, Sweden

**SF...W Ex frame**

**Cable Transit Device, SF...W**

 IECEx NEM 12.0015U  
 Ⓢ II2G Ex e IIC Gb  
 Ⓢ II2D Ex tb IIIC Db  
 Nemko 12ATEX1279U

Frame size 1-8 and combinations thereof  
 Min SF 1x1W to Max SF 8+8+8x10W

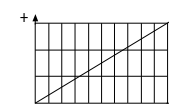

 0402

Temp. range -60 — + 80°C  
 IP65/IP66/IP67 depending on configuration,  
 see installation instruction.

 Canada: Ex e IIC USA: AEx e IIC,  
 Class I, Zone 1  
 System environmental rating:  
 1, 2, 3, 3S, 3R, 4, 4X, 5, 12 and 13.

Roxtec International AB, Rombvägen 2  
 SE-371 23 Karlskrona, Sweden

Year of manufacture

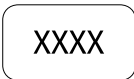

**UKCA conformity marking**

Can only be applied together with the ATEX and IECEx main frame label.

Applicable with Nemko 12ATEX1278X



Applicable with Nemko 12ATEX1279U



## DISCLAIMER

"The Roxtec cable entry sealing system ("the Roxtec system") is a modular-based system of sealing products consisting of different components. Each and every one of the components is necessary for the best performance of the Roxtec system. The Roxtec system has been certified to resist a number of different hazards. Any such certification, and the ability of the Roxtec system to resist such hazards, is dependent on all components that are installed as a part of the Roxtec system. Thus, the certification is not valid and does not apply unless all components installed as part of the Roxtec system are manufactured by or under license from Roxtec ("authorized manufacturer"). Roxtec gives no performance guarantee with respect to the Roxtec system, unless (I) all components installed as part of the Roxtec system are manufactured by an authorized manufacturer and (II) the purchaser is in compliance with (a), and (b), below.

(a) During storage, the Roxtec system or part thereof, shall be kept indoors in its original packaging at room temperature.

(b) Installation shall be carried out in accordance with Roxtec installation instructions in effect from time to time.

The product information provided by Roxtec does not release the purchaser of the Roxtec system, or part thereof, from the obligation to independently determine the suitability of the products for the intended process, installation and/or use. Roxtec gives no guarantee for the Roxtec system or any part thereof and assumes no liability for any loss or damage whatsoever, whether direct, indirect, consequential, loss of profit or otherwise, occurred or caused by the Roxtec systems or installations containing components not manufactured by an authorized manufacturer and/or occurred or caused by the use of the Roxtec system in a manner or for an application other than for which the Roxtec system was designed or intended.

Roxtec expressly excludes any implied warranties of merchantability and fitness for a particular purpose and all other express or implied representations and warranties provided by statute or common law. User determines suitability of the Roxtec system for intended use and assumes all risk and liability in connection therewith. In no event shall Roxtec be liable for indirect, consequential, punitive, special, exemplary or incidental damages or losses."



Roxtec International AB  
Box 540, 371 23 Karlskrona, SWEDEN  
PHONE +46 455 36 67 00, FAX +46 455 820 12  
EMAIL [info@roxtec.com](mailto:info@roxtec.com), [www.roxtec.com](http://www.roxtec.com)